



For use in small to medium sized dwellings

The enhanced capacity HRV1.75 Q Plus continuously running whole-house ventilation unit with heat recovery is independently tested by the BRE maintains an ultra compact size despite its improved results.

Combining extremely low power consumption and a highly efficient heat exchanger, this unit enhances SAP performance via Appendix Q, and yet remains versatile enough in size to be equally as functional in larger apartments as it is in small to medium sized dwellings.

The Eco versions offer a 100% airflow diverting Summer Bypass, recognised and listed in the UK Product Characteristics Database. They also include intelligent humidity options and can be fitted with the auralite® status indicator, aura-t™ (HMB and B models), auramode® and aurastat® controllers (B models only).

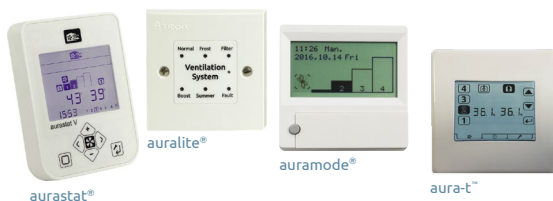

Features & Benefits

- Highly versatile compact unit
- Extremely low Specific Fan Power; down to 0.48 W/l/s
- Highly efficient heat exchanger; up to 89%
- Airflow up to 76 l/s (274 m³/h) at 100 Pa
- Accepts 125mm or 150mm diameter ducting, no adaptors required
- Intelligent frost protection, stepped reduction of supply air rates prevents HRV unit from freezing
- ISO Coarse 55% (G3) filters as standard with ISO Coarse 60% (G4) as an option
- Fully adjustable boost overrun timer 0-60 minutes; can be used with non-latching (momentary) switches to prevent unit from being accidentally left in boost mode
- Setback facility to reduce ventilation where local regulations allow
- Volt free switching control
- Intelligent controller, quick and easy to commission
- Quick fix mounting bracket
- IP32 rating
- On board aura-t™ option
- Patented
- Independent fan adjustment
- Effective in reducing pollutants in the home and improving Indoor Air Quality (IAQ), therefore reducing the risk of Toxic Home Syndrome

Basic version:

- Summer mode

Eco Versions:

- Intelligent Summer Bypass & humidity controls
- SUMMERboost® facility
- Available in left and right handed configurations

Eco HMB Models:

- Compatible with auralite® (TP518) status indicator and aura-t™ controller
- Fitted with removable filter covers on the front panel

Eco B Models:

- Compatible with Eco-aura range; aurastat®, auramode® and aura-t™ controllers and auralite® (TP519) status indicator
- Duct Pre-heater control (requires independent power supply)
- BMS compatible via RS485

Product Codes

HRV1.75 Q Plus -
TP404A - Energy Rating A

HRV1.75 Q Plus HMB Eco auralite® & aura-t™ ready -
TP404HMB/544 (left hand config) or
TP404HMB/RH (right hand config) - Energy Rating A

HRV1.75 Q Plus B Eco-aura controls ready -
TP414B/LH (left hand config) or
TP414B/RH (right hand config) - Energy Rating A+

Filters (Basic Version):

XP40132/099 - ISO Coarse 55% (G3) filters fitted as standard (UK only).

XP46122/099 - ISO Coarse 60% (G4) filters fitted on request (Europe fitted as standard).

Filters (Eco Versions):

XP40133/099 - ISO Coarse 55% (G3) filters fitted as standard (UK only).

XP46133/099 - ISO Coarse 60% (G4) filters fitted on request (Europe fitted as standard).

XP46222/099 - ISO Coarse 55% (G3)/ISO ePM1 55% (F7) filters available on request.

XP46232/099 - ISO Coarse 60% (G4) filters/ISO ePM1 55% (F7) filters available on request.

Standards

Conforms to requirements of UK statutory Building Regulations and Technical Standards for Ventilation and BRE 398.

SAP Appendix Q tested

Exceeds requirements of Building Regulations Approved Document L (England & Wales).

EU RoHS Directive compliant.

Conforms to requirements of EC council directives relating to Electromagnetic Compatibility and Electrical Safety:

2006/95/EC (LVD), 2004/108/EC (EMC)
 EN 60335-1:2002/A2:2006, EN 60335-2- 80:2003/A1:2004.

CE Marked.

Specification

Dimensions: 715mm wide x 490mm high (excluding ports) x 415mm deep (426mm with mounting bracket)

Weight: 24kg

Finish: White Paint

Materials:

Housing: Zintec sheet steel housing, powder coated white

Internals: Expanded polypropylene (EPP)

Heat exchanger: Polystyrene

Internal insulation: Closed cell foamed Nitrile rubber, class 'O' fire rating

Standard filters: Grade ISO Coarse 55% (G3) synthetic filters.

Guarantee period: 3 years (UK only)

Electrical: 230V ~ 50/60Hz, 3A fuse

Installation: Install in accordance with regulatory requirements, such as the Domestic Ventilation Compliance Guide (England & Wales) and the Residential Ventilation Association recommendations.

Maintenance: Service and filter clean/replacement subject to local environment - see product manual.

Acoustics: Full acoustic data available online www.titon.com/acoustics

Acoustic Data

Product	% of Max flow	Airflow	dB(A) @ 3m Hemispherical			dB(A) @ 3m Spherical
			Induct Inlet	Induct Outlet	Casing Breakout	Casing Breakout
HRV1.75 Q Plus Eco	39%	30l/s @ 18Pa	26	36	22	19
	60%	47l/s @ 47Pa	31	46	22	19
	100%	78l/s @ 100Pa	40	54	30	27

For full frequency acoustic data at various speeds please see www.titon.com. All acoustic data is third party tested at Sound Research Laboratories (SRL) Ltd.

Drawing & Dimensions

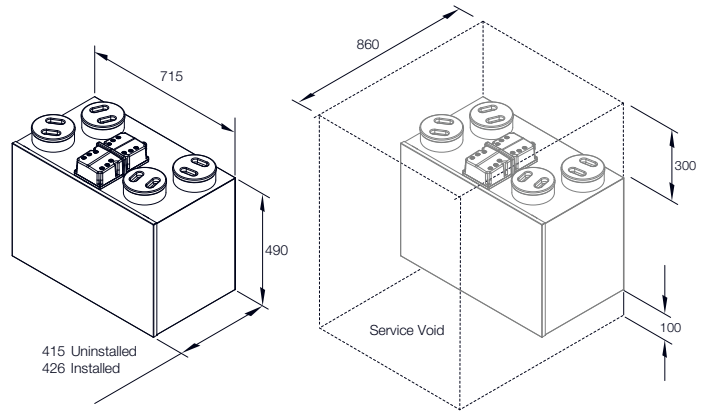

Dimensions in mm

Performance

The figures and compliance levels below relate to current SAP requirements. Revised SAP guidance will have an effect on performance and up-to-date figures can be found on the relevant product page at www.titon.com.

Exhaust terminal configuration*	Fan speed setting	2009		2012	
		SFP (W/l/s)	Heat exchange efficiency (%)	SFP (W/l/s)	Heat exchange efficiency (%)
Kitchen + 1 additional wet room	100% variable	0.48	89%	0.52	89%
Kitchen + 2 additional wet rooms	100% variable	0.49	89%	0.6	89%
Kitchen + 3 additional wet rooms	100% variable	0.55	89%	0.73	88%
Kitchen + 4 additional wet rooms	100% variable	0.64	88%	0.94	87%
Kitchen + 5 additional wet rooms	100% variable	0.76	88%	-	-
Kitchen + 6 additional wet rooms	100% variable	0.91	87%	-	-
Kitchen + 7 additional wet rooms	100% variable	1.11	87%	-	-

Figures taken from the BRE Test Results

*Number of wet rooms is based on SAP Q test criteria and does not correlate directly with regulatory performance requirements.

Nominal Fan Performance

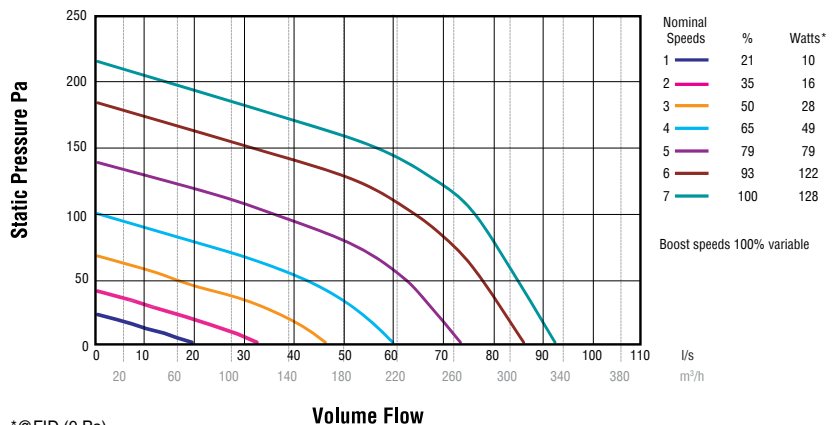

*@FID (0 Pa)
 All units offer 100% variable speed control.
 Performance curves for Eco version.