

Kenrick Centurion

Security shootbolt espagnolette

Suitable for:

PVCu



ALUMINIUM



TIMBER



Centurion is an adaptable locking system providing high levels of security whilst also satisfying the demand for cost effective production.

Centurion allows window fabricators of any size the opportunity to market a high value finished product at a cost effective price.



Features and Benefits

- Simple to install
- Mushroom bolts
- Secure by Design
- Available in 20mm and 22mm backset gearbox
- Robust unhandled die-cast gearbox
- Profile related keeps with night vent facility
- Steel shootbolts
- Low handle height capability
- Tested to 100,000 cycles
- 10 year mechanical and design guarantee
- Minimum of 240 hours salt spray testing - BSEN 1670:2007
- PAS24 Capable

Handle fixing and lockcase routing detail

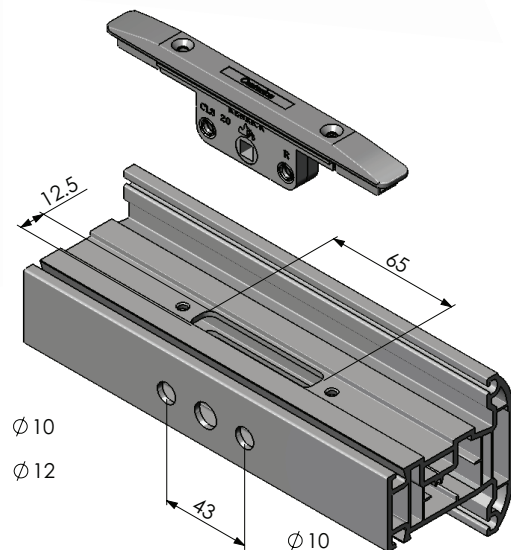

Centurion Gear Box

Product Code	Gearbox Backset (mm)
CLS20	20
CLS22	22

Standard Extension Part Numbers (With Adjustable Mushroom Cams)

Product Code	Sash Rebate Size	Number of Locking Points
CLS240370	250-376	2
CLS370620	376-634	4
CLS620890	634-892	4
CLS8901155	892-1156	4

Size range

250-1414mm espagnolette lengths **(Standard Extension)**

568-1466mm **(Plus Extension)**

300mm Extension - EXD300EXTM **(With Mushroom)**

300mm Extension - EXD300EXT **(Without Mushroom)**

Manufactured from

Gearbox- Zinc

Extensions- Mild Steel

Striker- Zinc

Finish

Zinc plate

Performance

(Full test details available on request.)

Minimum of 240 hours salt spray testing - BSEN 1670:2007

When ordering please specify:

1. Espagnolette type
2. Sash rebate
3. Backset size
4. Cam size
5. Profile name and number

More information

enquiries@titon.co.uk / 01206 713801

Lockcase dimensions

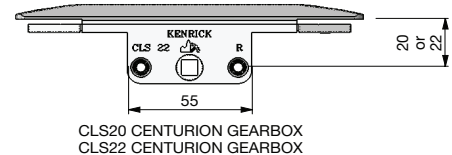

End detail

