

Important: Read these instructions fully before installation.

1. Installation of the appliance and accessories **MUST** be carried out by a qualified and suitable competent person.
2. All wiring must conform to current I.E.E. Wiring Regulations and all applicable national standards and Building Regulations.
3. Installation must be inspected and tested by a suitably qualified person after completion.
4. Installation of the appliance must be carried out in clean, dry conditions where dust and humidity are at minimal levels.
5. This appliance can be used by children aged from 8 years and above and persons with reduced physical, sensory or mental capabilities or lack of experience and knowledge if they have been given supervision or instruction concerning use of the appliance in a safe way and understand the hazards involved.
6. Children should be supervised to ensure that they do not play with the appliance.

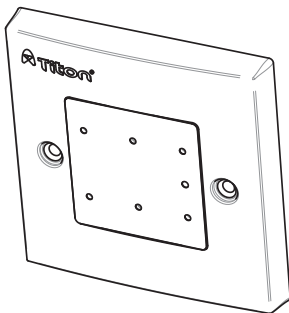

auralite®
TP518

LED Status Indicator



auralite®

auralite® is a low voltage hard wired remote LED ventilation system status indicator, designed to fit a standard UK patress or recessed backbox. The indicator is for use with specific Titon HRV units. The indicator has six LEDs which display:-

- Normal Solid light - Unit is running at Continuous Speed.
 Flashing light- Unit is running at Setback Speed.
- Frost Unit is in Automatic Frost Protection mode.
- Filter Filters require change.

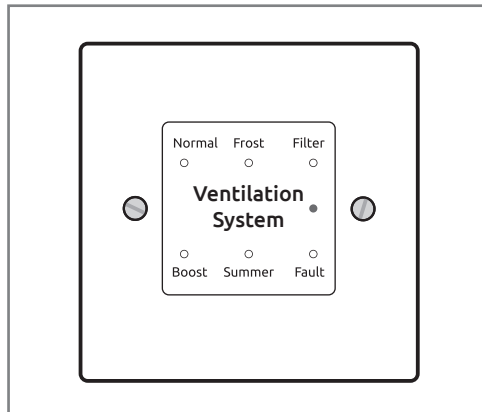

auralite® Indicator Panel

- Boost Solid light unit is running at Boost Speed.
 Flashing light Boost Alert is active.
- Summer Unit is in Summer -bypass or Summer Mode; model dependant.
- Fault Unit has a fault - Contact the installer.

Wiring Diagrams

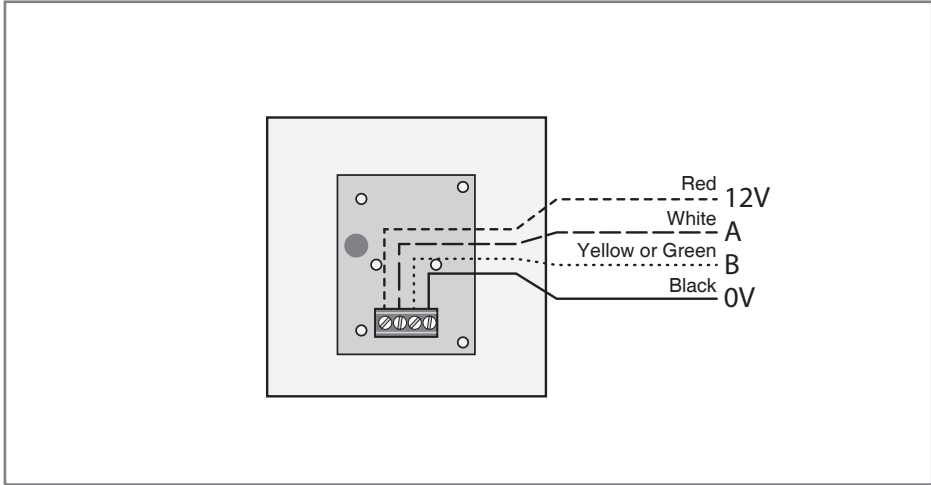

auralite® connection at Indicator

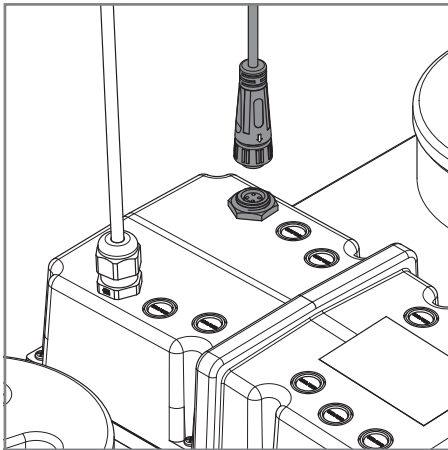

typical plug connection to HRV

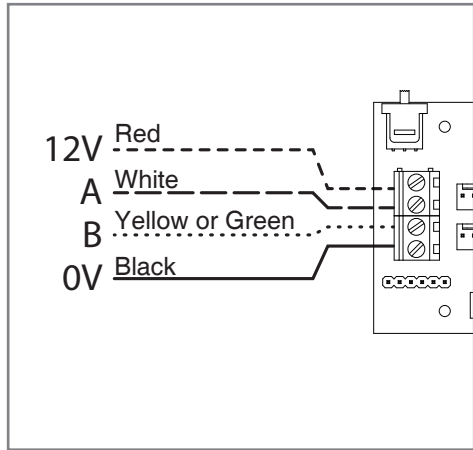

Wire connection to HRV

Wiring

1. Using Male Plug Connector & wire XP 40368 3m
Communication Cable XP 47074A 3m
 XP 47074 30m

or alternately unshielded 4 Core 18-24AWG Stranded, Tinned Copper.

2. Communication cable should not be placed within 50mm or on the same metal cable tray as 230V switched live, lighting or power cables and any cables not intended for use with the HRV.

Filter notification reset

Following a filter change to HRV the auralite® will require resetting, see below. Ensure the HRV is powered up. To clear the auralite® filter notification press & hold the reset switch with a ball point pen or similar object for 10 second. The switch is located behind the small hole in the front of the auralite®. All lights will momentarily be illuminated indicating a successful reset.



MARKETING DIVISION

894 The Crescent Colchester Business Park COLCHESTER Essex CO4 9YQ

Tel: +44 (0) 1206 713800 Fax: +44 (0) 1206 543126

Email: ventsales@titon.co.uk Web: www.titon.com