

Ventilation Systems

Full Product Catalogue



REDEFINING WHOLE HOUSE VENTILATION....

Titon's MVHR HRV Q Plus range just got bigger (the size hasn't though)

INTRODUCING THE NEW HRV4 & HRV4.25 Q PLUS



- ▶ Airflow up to 158 l/s (568 m³/h) at 100 Pa
- ▶ Low Specific Fan Power; down to 0.38 W/l/s
- ▶ Highly efficient heat exchanger; up to 91%
- ▶ 600mm (w) x 602mm (h) x 477mm (d)
- ▶ Left or Right Hand on site configuration
- ▶ Full MODBUS and WiFi connectivity

[TITON.COM/BIGLITTLEMVHR](https://www.titon.com/biglittlemvhr)



Contents

Welcome to Titon Ventilation Systems. We are experts in the design, manufacture, specification and supply of residential ventilation systems. Our extensive range and comprehensive support will provide you with a solution for any housing project.

Titon - Your Ventilation Expert	4
Quality and Testing	5
Recommended Ventilation Systems	6

Heat Recovery (MVHR)	8
HRV Overview	8
HRV1.25 Q Plus	10
HRV1.3 Q Plus	12
HRV1.35 Q Plus	14
HRV1.35 Q Plus - Enthalpy	16
HRV1.6 Q Plus	18
HRV1.6 Q Plus - Enthalpy	20
HRV1.65 Q Plus	22
HRV4 Q Plus	24
HRV4.25 Q Plus	26
HRV20 HE Q Plus	28
HRV20 HE Q Plus - Enthalpy	30
H200 Q Plus	32
HRV Cool Plus™	34
SR700	40

HRV Accessories	42
Trimbox NO ₂ Filter®	42
Trimbox Filter®	44
HRV Condensate Drain Cover	46
HRV Duct Cover	47
HRV First Fix Solutions	48
HRV AV Mounting Kits	49
Duct Pre-heater	50

Continuous Mechanical Ventilation (MEV)	52
CME2 Q Plus	52
CME2.1 Q Plus	54
CME3 Q Plus	56
CME3.1 Q Plus	58
Titon Ultimate® dMEV	60
Titon Ultimate® Active Vent	62

Controls, Switches and Sensors	64
auraSMART® app	64
aura-t™ SMART (WiFi)	65
aura-t™ (B)	66
aura-t™ (HMB)	67
auralite® HRV	68
auralite® CME	69
Touch Button Timer	70
PIR Movement - Sensor	71
PIR Presence/Absence	72
Room Sensor VOC	73
Room Sensor CO ₂	74
Room Sensor Humidity	75
Switches	76

Other Systems	78
Sonair 3	78
Positive Input Ventilation (PIV)	80

Extract Fans	84
Purge Ventilation Unit	84
Intermittent Fans - Axial	86
Intermittent Fans - Centrifugal	88
Vent-Trex	90

Trickle Ventilators	92
Window Ventilators	92
AirLiner	94
AirCore	96

Ducting and Accessories	98
100mm - Round Ducting	98
125mm - Round Ducting	100
150mm - Round Ducting	102
110x54mm - Rectangular Ducting	104
234x29mm - Rectangular Ducting	105
204x60mm - Rectangular Ducting	106
220x90mm - Rectangular Ducting	108
Ceiling Diffuser Supply/Extract (125mm)	110
Ceiling Air Valve (Extract) - Standard	112
Ceiling Air Valve (Supply) - Standard	113
Ceiling Air Valve (Extract) - Fire Rated	114
Ceiling Air Valve (Supply) - Fire Rated	115
Semi-rigid Ducting	116
Thermal Ducting	117
Sound Attenuators - Semi Flexible	118
Sound Attenuators - Rigid Ducting	120
Q Plus High Flow Brick - Plastic	122
Titon FireSafe® - Single Air Brick	124
Titon FireSafe® - Double Air Brick	129
Titon FireSafe® - 100mm Push Through Wall Kit	132
Fire Sleeve - Ducting	134
Fire Sleeve (Slim) - Ducting	135
CFC Ceiling Fan Cuff	136
Self-Seal Connectors	137
Roof Terminals	138

After care and Support	139
Product Care & Maintenance	139
Further Information	140

Titon - Your Ventilation Expert

Titon has a strong presence in the UK residential ventilation market with a comprehensive range of mechanical and natural ventilation products and is also a leading supplier of window and door hardware. We sell our products into a range of European markets and the USA market is supplied through a wholly owned subsidiary, Titon Inc.



Titon prides itself on its Sales Team who have vast Regulatory and Standards knowledge and can offer Accredited CPD training and ongoing technical support to your Technical and On-Site team.

Orders are placed directly with Titon. This enables project vigilance to be effectively managed when working to production demands, specific plots schedules and co-ordination of call off orders.

Our in-house Design Office can receive drawings in CAD and Revit format. We will provide detailed ventilation designs with commissioning data and specific Acoustic results. All designs are sent over for approval and we are happy to co-ordinate with your specialized consultants.

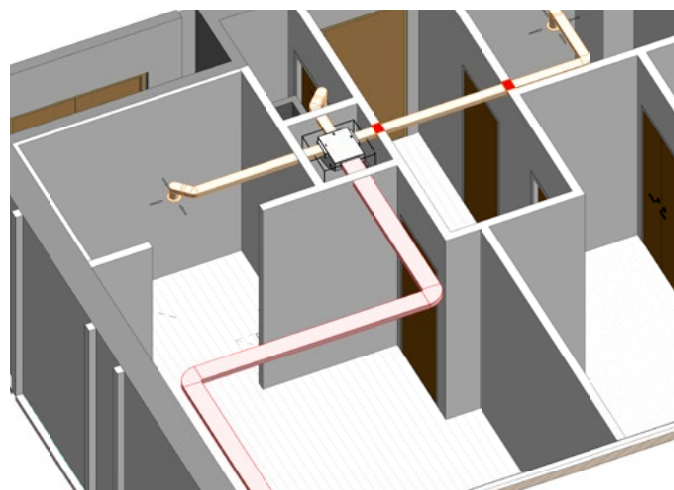

On site training or online available.

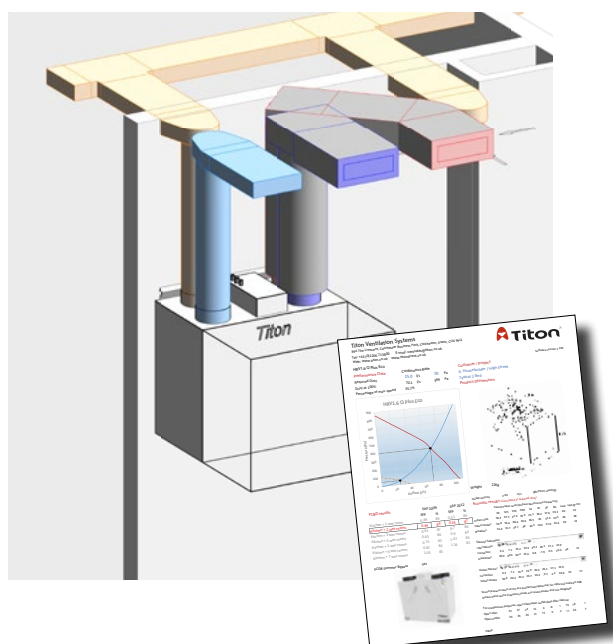

Quality and Testing

When it comes to quality, Titon is committed to excellence and the total satisfaction of its customers and their specific requirements. It strives to be an efficient supplier and to offer its customers a prompt, courteous and effective service. The company seeks to handle and deliver products and services in a manner that is not detrimental to the environment or to the Health and Safety of its staff, customers, or the general public both inside and outside its facilities.

Titon's objective of consistent high quality performance is met by mandatory adherence to procedures, and Titon has full ISO 9001 Certification. This ensures standards are met and monitored in eight core quality management areas, including customer focus, leadership, the involvement of people, a process approach, a systematic approach to management, continual improvement, a factual approach to decision making and mutually beneficial supplier relationships. In addition, Titon also holds the ISO 14001 Environmental Management Standard Certification.

Titon has a large research, development and testing department in Haverhill, Suffolk. All of Titon's products are subjected to a rigorous regime of quality testing to ensure they meet the performance criteria specified, as well as delivering reliability and optimum performance.

Perhaps uniquely in the Ventilation Systems sector, Titon whole-house units are tested on the production line to ensure performance and air tightness levels which match those achieved when each model was officially third party tested. This is true both of units being sold in the UK and those models subject to sometimes more rigorous testing for export into mainland Europe.

To enable Titon to demonstrate its quality, it will test products, wherever applicable, to the latest British and European standards – including full CE approval.



All MVHR are tested for air leakage



All MVHR are electronically tested



Full details of our products can be found on 'Product Characteristics Database'



All acoustic data is third party tested at Sound Research Laboratories (SRL) Ltd



FM26687



EMS 513709



Recommended Ventilation Systems

Natural ventilation with background ventilators & intermittent extract fans

(guidance suitable only for less airtight dwellings)

(Formerly System 1)

Where can it be used?

Suitable for new build or refurbishment; houses, flats or apartments with multi façades.

How does it work?

Background ventilators (trickle vents in windows) provide supply ventilation.

Intermittent extract fans remove odours and excessive humidity in wet rooms such as kitchen and bathrooms.

What ventilation products can be used?

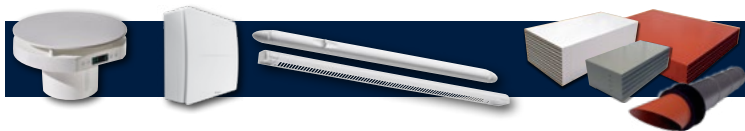

Titon Ultimate® (Intermittent option) and TIFC/A range of Intermittent Fans and Trickle Vents



Continuous mechanical extract ventilation - Decentralised dMEV (Option)

(Formerly System 3)

Where can it be used?

Suitable for new build or refurbishment; houses, flats or apartments, usually in dwellings that are classed as 'highly airtight dwellings' in Part F.

How does it work?

Background ventilators (trickle vents in windows) provide supply ventilation.

Continuously running decentralised fans remove odours and excessive humidity in wet rooms such as kitchen and bathrooms.

A boost facility (where applicable) provides rapid extraction when necessary to remove high levels of pollutants.

What ventilation products can be used?

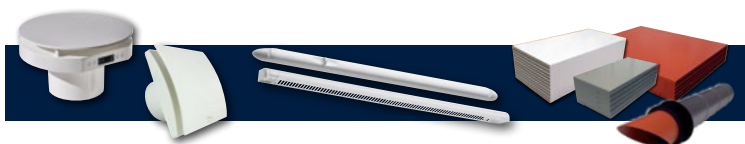

Titon Ultimate® dMEV and Trickle Vents



Continuous mechanical extract ventilation - Centralised MEV (Option)

(Formerly System 3)



Where can it be used?

Suitable for new build; houses, flats or apartments, usually in dwellings that are classed as 'highly airtight dwellings' in Part F.

How does it work?

Background ventilators (trickle vents in windows) provide supply ventilation.

A centrally located continuously running mechanical extract fan extracts air via ducts from wet rooms to remove odours and excessive humidity.

A boost facility (where applicable) provides rapid extraction when necessary to remove high levels of pollutants.



What ventilation products can be used?

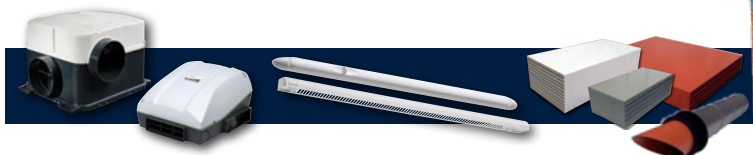

CME Q Plus range of Continuous Mechanical Ventilation fans and Trickle Vents

Mechanical ventilation with heat recovery - MVHR

(Formerly System 4)



Where can it be used?

Suitable for new build; houses, flats or apartments, usually in dwellings that are classed as 'highly airtight dwellings' in Part F.

How does it work?

A mechanical ventilation heat recovery system (MVHR) works by combining **supply** and **extract** air.

Moisture-laden, **stale air is extracted from wet areas**, such as kitchens and bathrooms. The heat from the extract air is recovered by the heat exchanger in the MVHR unit and is recycled by warming up the **supply air** entering a dwelling.



What ventilation products can be used?



HRV Q Plus range of Mechanical Ventilation fans

Part Number	HRV1.25 Q Plus			HRV1.3 Q Plus		HRV1.35 Q Plus		HRV1.6 Q Plus		HRV1.65 Q Plus	
	TP406A	TP406HMB	TP416B	TP473HMB	TP474B	TP409HMB	TP418B	TP409HMB	TP419B	TP439HMB	TP429BF
Size											
Width	600	600	600	600	600	600	600	600	600	600	600
Height	430	430	430	430	430	430	430	505	505	505	505
Depth	285	285	285	285	285	285	285	353	353	353	353
Depth (inc mounting bracket)	295	295	295	295	295	295	295	363	363	363	363
Weight (Kg)	16	16	16	16	16	16	16	22	22	22	22
Number of Kitchen + Wet Rooms (Max)	4	4	4	6	6	6	6	7	7	7	7
Heat Recovery	91	91	91	85	85	85	85	89	89	90	90
SFP (W/L/S)	0.59	0.59	0.59	0.65	0.65	0.65	0.65	0.49	0.49	0.62	0.62
Airflow (m³/h) at 100Pa	190	158	158	208	208	217	217	359	359	290	290
Airflow (l/s) at 100Pa	53	44	44	58	58	60	60	88	88	81	81
Sound Level dB*	23	23	23	26	26	29	29	24	24	31	31
Passivhaus											
Enthalpy Option**								•		•	
Cold Climate Option								•		•	
Ducting Size											
125mmØ	•	•	•	•	•	•	•	•	•	•	•
150mmØ											
160mmØ											
180mmØ											
200mmØ											
204x60											
Housing											
Zintec Sheet Steel	•	•	•	•	•	•	•	•	•	•	•
Expanded Polypropylene											
Mounting											
Horizontal/Wall	•	•	•	•	•	•	•	•	•	•	•
Vertical/Ceiling Void											
Controllers											
auralite* (TP518)		•		•		•		•		•	
auralite* HRV (TP519)			•		•		•		•		•
aura-t* HMB (TP539)***			•		•		•		•		•
aura-t* B (TP536)***		•		•		•		•		•	
aura-t* SMART ***		•		•		•		•		•	
SRC1 (Control unit)											
Other options											
Filter Access - Removable covers	•	•		•		•		•		•	
Filter Access - Drop down panel			•		•		•		•		•
Humidity sensor		•	•	•	•	•	•	•	•	•	•
SUMMERboost*		•	•	•	•	•	•	•	•	•	•
Summer Bypass		•	•	•	•	•	•	•	•	•	•
Summer Mode	•										
Duct Pre-heater Connection			•		•		•		•		•
Independent Fan Adjustment	•	•	•	•	•	•	•	•	•	•	•
Sleepless fan speed setting	•	•	•	•	•	•	•	•	•	•	•
Automatic Frost Protection	•	•	•	•	•	•	•	•	•	•	•
Setback speed	•	•	•	•	•	•	•	•	•	•	•
Adjustable boost overrun timer	•	•	•	•	•	•	•	•	•	•	•
Left and Right hand option		•	•	•	•	•	•	•	•	•	•

Key

- Standard Units
- Non-Standard Units

Explanation of features

- Normal** - Continuously running extract and supply, set on install in accordance with the requirements of the applicable Regulations.
- Boost** - Increases ventilation rates on demand, set on install in accordance with the requirements of the applicable Regulations.
- Setback** - Provides a reduced ventilation rate for dwellings that are unoccupied for a long period.
- SUMMERboost*** - Only available with Eco versions, increases both the supply and extract to full speed when the automatic bypass engages.

Part Number	HRV4 Q Plus		HRV4.25 Q Plus		HRV20 HE Q Plus		H200 Q Plus						SR700
	TP421HMB	TP431B2	TP423HMB	TP433B2	TP652HMB	TP653B	TP451HMB	TP453HMB	TP452HMB	TP461B	TP463B	TP462B	TP600
Size													
Width	600	600	600	600	752	752	1000	1000	1000	1000	1000	1000	
Height	602	602	602	602	708	708	200	200	200	200	200	200	
Depth	477	477	477	477	533	533	600	600	600	600	600	600	
Depth (inc mounting bracket)	487	487	487	487	549	549							
Weight (Kg)	28.5	28.5	28.5	28.5	46	46	32	32	32	32	32	32	3
Number of Kitchen + Wet Rooms (Max)	7	7	7	7	7	7	7	7	7	7	7	7	
Heat Recovery	91	91	91	91	92	92	83	83	83	83	83	83	50
SFP (W/L/S)	0.38	0.38	0.43	0.43	0.48	0.48	0.55	0.55	0.55	0.55	0.55	0.55	0.24
Airflow (m³/h) at 100Pa	443	443	568	568	640	640	300	300	300	300	300	300	42
Airflow (l/s) at 100Pa	123	123	158	158	178	178	83	83	83	83	83	83	12
Sound Level dB*	26	26	32	32	35	35	31	31	31	31	31	31	ENQ
Passivhaus													
Enthalpy Option**						•							
Cold Climate Option	•	•	•	•		•				•	•	•	
Ducting Size													
125mmØ													
150mmØ	•	•	•	•					•			•	
160mmØ								•			•		
180mmØ													•
200mmØ					•	•							
204x60							•			•			
Housing													
Zintec Sheet Steel	•	•	•	•	•	•	•	•	•	•	•	•	
Expanded Polypropylene													•
Mounting													
Horizontal/Wall	•	•	•	•	•	•							•
Vertical/Ceiling Void							•	•	•	•	•	•	
Controllers													
auralite® (TP518)					•		•	•	•				
auralite® HRV (TP519)						•				•	•	•	
aura-t™ HMB (TP539)***	•		•		•	•				•	•	•	
aura-t™ B (TP536)***		•		•		•	•	•	•				
aura-t™ SMART***		•		•		•	•	•	•				
SRC1 (Control unit)													•
Other options													
Filter Access - Removable covers	•		•		•								
Filter Access - Drop down panel		•		•		•							
Humidity sensor	•	•	•	•	•	•	•	•	•	•	•	•	
SUMMERboost®	•	•	•	•	•	•	•	•	•	•	•	•	
Summer Bypass	•	•	•	•	•	•	•	•	•	•	•	•	
Summer Mode													
Duct Pre-heater Connection		•		•		•				•	•	•	
Independent Fan Adjustment	•	•	•	•	•	•	•	•	•	•	•	•	
Sleepless fan speed setting	•	•	•	•	•	•	•	•	•	•	•	•	
Automatic Frost Protection	•	•	•	•	•	•	•	•	•	•	•	•	
Setback speed	•	•	•	•	•	•	•	•	•	•	•	•	
Adjustable boost overrun timer	•	•	•	•	•	•	•	•	•	•	•	•	
Left and Right hand option	•	•	•	•	•	•							

Summer Bypass -

Titon Eco units are automatically controlled with a thermal bypass of the heat exchanger when indoor and outdoor temperature conditions make heat exchange undesirable.

* Breakout sound pressure level at 3m hemispheric at 53% of max flow.

Duct Pre-heater Control -

Used for the automatic control of in-line Duct Pre-Heaters to help prevent heat exchanger freezing.

**Performance may differ from standard unit. Enquire for further details.

Summer Mode -

Turns off the supply air, providing a thermal bypass on demand or via a remote thermostat (additional controllable background ventilation may be required).

***Available with onboard capabilities

HRV1.25 Q Plus

Ultra energy efficient Heat Recovery Ventilation unit

For use in small to medium sized dwellings

The enhanced capacity ultra compact HRV1.25 Q Plus continuously running whole-house ventilation unit with heat recovery is independently tested by the BRE.

Combining ultra low power consumption and a highly efficient heat exchanger, the HRV1.25 Q Plus is specifically designed to enhance SAP performance via Appendix Q - yet the unit remains small enough to be easily incorporated into apartments and smaller houses where space is at a premium.

Recognised and listed in the UK Product Characteristics Database and includes intelligent humidity options through controller options.

MVHR

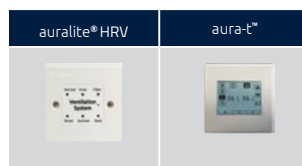
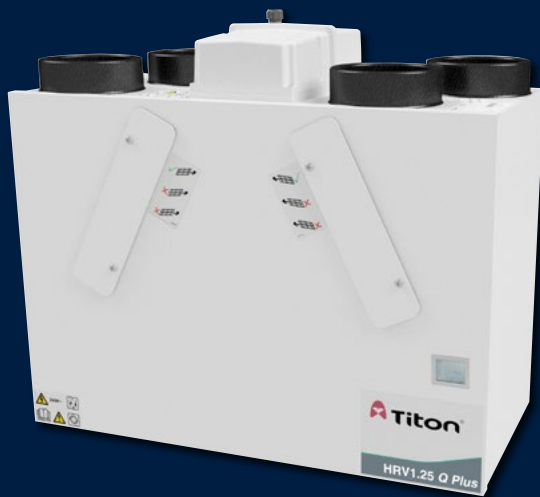

Features & Benefits

- Extremely compact
- Extremely low Specific Fan Power; down to 0.59 W/l/s
- Highly efficient heat exchanger; up to 88%
- Airflow up to 158l/s (568 m³/h) at 100 Pa
- Accepts 125mm diameter ducting, no adaptors required
- Intelligent frost protection, stepped reduction of supply air rates prevents HRV unit from freezing
- ISO Coarse 55% (G3) filters as standard with ISO Coarse 60% (G4) as an option
- Fully adjustable boost overrun timer 0-60 minutes; can be used with non-latching (momentary) switches to prevent unit from being accidentally left in boost mode
- Setback facility to reduce ventilation where local regulations allow
- Volt free switching control
- Removable airtight filter covers for easy filter maintenance (Standard and Eco model)
- Quick fix mounting bracket
- IP32 rating
- On board aura-t™ option
- Patented features and design
- Independent fan adjustment
- Intelligent controller, quick and easy to commission
- Effective in reducing pollutants in the home and improving Indoor Air Quality (IAQ), therefore reducing the risk of Toxic Home Syndrome

Basic version:

- Summer Mode

Eco Versions:

- Intelligent Summer Bypass & humidity controls
- SUMMERboost® facility
- Available in left and right handed configurations

Eco HMB Models:

- Compatible with auralite® HRV (TP518) status indicator and aura-t™ controller
- Fitted with removable filter covers on the front panel
- Standard - Volt free switching control
- Optional - Switch live control available with via Relay (TP505)

Eco B Models:

- Compatible with Eco-aura range; aurastat®, auramode® and aura-t™ controllers and auralite® HRV (TP519) status indicator
- Duct Pre-heater control (requires independent power supply)
- BMS compatible via RS485 (subject to limitations, additional software requirements and specification with any order)
- Standard - Volt Free switching and switch live control

Product Codes

HRV1.25 Q Plus -
TP406A - Energy Rating A

HRV1.25 Q Plus HMB Eco auralite® & aura-t™ ready -
TP406HMB/544 (left hand config) or
TP406HMB/RH (right hand config) - Energy Rating A

HRV1.25 Q Plus B Eco-aura controls ready -
TP416B/LH (left hand config) or
TP416B/RH (right hand config) - Energy Rating A

Filters (Basic and Eco Versions):
XP40032/099 - ISO Coarse 55% (G3) filters fitted as standard (UK only).
XP46022/099 - ISO Coarse 60% (G4) filters fitted on request (Europe fitted as standard).
XP2011094/099 - ISO Coarse 55% (G3)/ISO ePM1 50% (F7) filters available on request.
XP2011095/099 - ISO Coarse 60% (G4)/ISO ePM1 50% (F7) filters available on request.

Standards

Conforms to requirements of UK statutory Building Regulations and Technical Standards for Ventilation and BRE 398.

SAP Appendix Q tested.

Exceeds requirements of Building Regulations Approved Document L (England & Wales).

EU RoHS Directive compliant.

Conforms to requirements of EC council directives relating to Electromagnetic Compatibility and Electrical Safety:

2006/95/EC (LVD), 2004/108/EC (EMC)
 EN 60335-1:2002/A2:2006, EN 60335-2- 80:2003/A1:2004.

CE and UKCA marked.

Specification

Dimensions: 600mm wide x 430mm high (excluding ports) x 285mm deep (295mm with mounting bracket)

Weight: 16kg

Finish: White Paint

Materials:

Housing: Zintec sheet steel housing, powder coated white

Internals: Expanded polypropylene (EPP)

Heat exchanger: Polystyrene

Internal insulation: Closed cell foamed Nitrile rubber, class 'O' fire rating

Standard filters: Grade ISO Coarse 55% (G3) synthetic filters

Guarantee period: 3 years (UK only)

Electrical: 230V ~ 50/60Hz, 3A fuse

Installation: To be installed accordance with the relevant and applicable building regulations.

Maintenance: Service and filter clean/replacement subject to local environment - see product manual.

Acoustics: Full acoustic data available online www.titon.com/acoustics.

Drawing & Dimensions

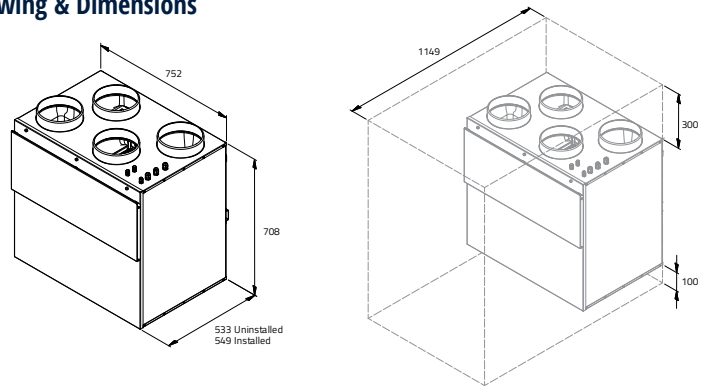

Dimensions in mm

Performance

The figures and compliance levels below relate to current SAP requirements. Revised SAP guidance will have an effect on performance and up-to-date figures can be found on the relevant product page at www.titon.com.

Exhaust terminal configuration*	Fan speed setting	2009		2012	
		SFP (W/l/s)	Heat exchange efficiency (%)	SFP (W/l/s)	Heat exchange efficiency (%)
Kitchen + 1 additional wet room	100% variable	0.59	88%	0.68	87%
Kitchen + 2 additional wet rooms	100% variable	0.67	87%	0.9	85%
Kitchen + 3 additional wet rooms	100% variable	0.82	85%	1.21	84%
Kitchen + 4 additional wet rooms	100% variable	1.04	84%	-	-

Figures taken from the BRE Test Results.

*Number of wet rooms is based on SAP Q test criteria and does not correlate directly with regulatory performance requirements.

Nominal Fan Performance

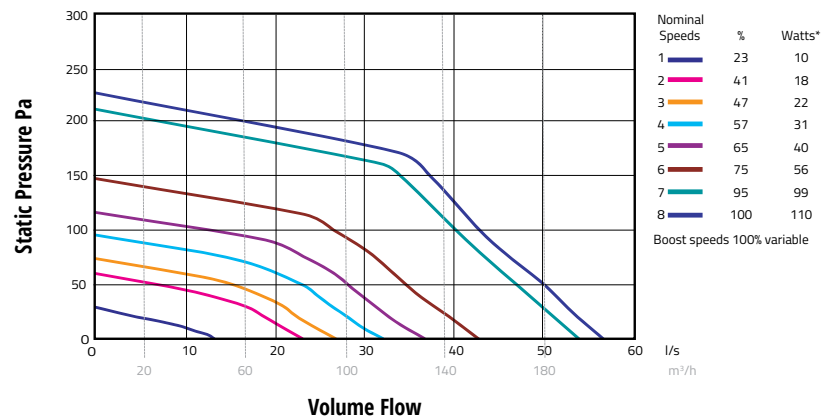

*@FID (0 Pa)
 100% variable speed control. Performance curves for Eco version.

Acoustic Data

Product	% of Max flow	Airflow	dB(A) @ 3m Hemispherical			dB(A) @ 3m Spherical
			Induct Inlet	Induct Outlet	Casing Breakout	Casing Breakout
HRV1.25 Q Plus	40%	22l/s @ 10Pa	28	41	20	17
	61%	34l/s @ 23Pa	36	49	28	25
	100%	56l/s @ 50Pa	43	57	36	33

For full frequency acoustic data at various speeds please see www.titon.com. All acoustic data is third party tested at Sound Research Laboratories (SRL) Ltd.

HRV1.3 Q Plus

Ultra energy efficient Heat Recovery Ventilation unit

For use in small to medium sized dwellings

The enhanced capacity ultra compact HRV1.3 Q Plus continuously running whole-house ventilation unit with heat recovery is independently tested by the BRE and maintains an ultra compact size despite its improved airflow performance.

Combining extremely low power consumption and a highly efficient heat exchanger, this unit enhances SAP performance via Appendix Q, and yet remains versatile enough in size to be equally as functional in larger apartments as it is in small to medium sized dwellings.

Recognised and listed in the UK Product Characteristics Database and includes intelligent humidity options through controller options.

MVHR

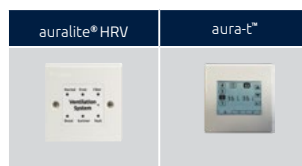
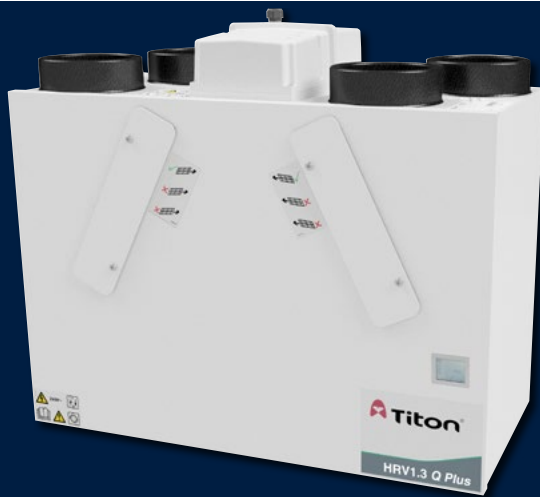

Features & Benefits

- Highly versatile compact unit
- Extremely low Specific Fan Power; down to 0.65 W/l/s
- Highly efficient heat exchanger; up to 88%
- Airflow up to 58l/s (208 m³/h) at 100 Pa
- Accepts 125mm diameter ducting, no adaptors required
- Intelligent frost protection, stepped reduction of supply air rates prevents HRV unit from freezing
- ISO Coarse 55% (G3) filters as standard with ISO Coarse 60% (G4) as an option
- Enthalpy Heat Cell option available
- Fully adjustable boost overrun timer 0-60 minutes; can be used with non-latching (momentary) switches to prevent unit from being accidentally left in boost mode
- Setback facility to reduce ventilation where local regulations allow
- Intelligent Summer Bypass and humidity controls
- Volt free switching control
- Intelligent controller, quick and easy to commission
- Lightweight for easy handling
- Quick fix mounting bracket
- IP32 rating
- On board aura-t™ option
- Patented
- Independent fan adjustment
- SUMMERboost® facility
- Effective in reducing pollutants in the home and improving Indoor Air Quality (IAQ), therefore reducing the risk of Toxic Home Syndrome
- Intelligent Summer Bypass & humidity controls
- SUMMERboost® facility
- Available in left and right handed configurations

Eco HMB Models:

- Compatible with auralite® HRV (TP518) status indicator and aura-t™ controller
- Fitted with removable filter covers on the front panel
- Standard - Volt free switching control
- Optional - Switch live control available with via Relay (TP505)

Eco B Models:

- Compatible with Eco-aura range; aurastat®, auramode® and aura-t™ controllers and auralite® HRV (TP519) status indicator
- Duct Pre-heater control (requires independent power supply)
- BMS compatible via RS485 (subject to limitations, additional software requirements and specification with any order)
- Standard - Volt Free switching and switch live control



Product Codes

HRV1.3 Q Plus HMB Eco auralite® & aura-t™ ready -
TP473HMB/544 (left hand config) or
TP473HMB/RH (right hand config) - Energy Rating A

HRV1.3 Q Plus B Eco-aura controls ready -
TP474B/LH (left hand config) or
TP474B/RH (right hand config) - Energy Rating A
TP474BF (Door) - Energy Rating A

Filters:

XP40032/099 - ISO Coarse 55% (G3) filters fitted as standard (UK only).
XP46022/099 - ISO Coarse 60% (G4) filters fitted on request. (Europe fitted as standard).
XP2011094/099 - ISO Coarse 55% (G3)/ISO ePM1 50% (F7) filters available on request.
XP2011095/099 - ISO Coarse 60% (G4)/ISO ePM1 50% (F7) filters available on request.

Standards

Conforms to requirements of UK statutory Building Regulations and Technical Standards for Ventilation and BRE 398.

SAP Appendix Q tested.

Exceeds requirements of Building Regulations Approved Document L (England & Wales).

EU RoHS Directive compliant.

Conforms to requirements of EC council directives relating to Electromagnetic Compatibility and Electrical Safety:

2006/95/EC (LVD), 2004/108/EC (EMC)
 EN 60335-1:2002/A2:2006, EN 60335-2- 80:2003/A1:2004.

CE and UKCA marked.

Specification

Dimensions: 600mm wide x 430mm high (excluding ports) x 285mm deep (295mm with mounting bracket)

Weight: 16kg

Finish: White Paint

Materials:

Housing: Zintec sheet steel housing, powder coated white

Internals: Expanded polypropylene (EPP)

Heat exchanger: Polystyrene

Internal insulation: Closed cell foamed

Nitrile rubber, class 'O' fire rating

Standard filters: Grade ISO Coarse 55% (G3) synthetic filters

Guarantee period: 3 years (UK only)

Electrical: 230V ~ 50/60Hz, 3A fuse

Installation: To be installed accordance with the relevant and applicable building regulations.

Maintenance: Service and filter clean/replacement subject to local environment - see product manual.

Acoustics: Full acoustic data available online www.titon.com/acoustics.

Drawing & Dimensions

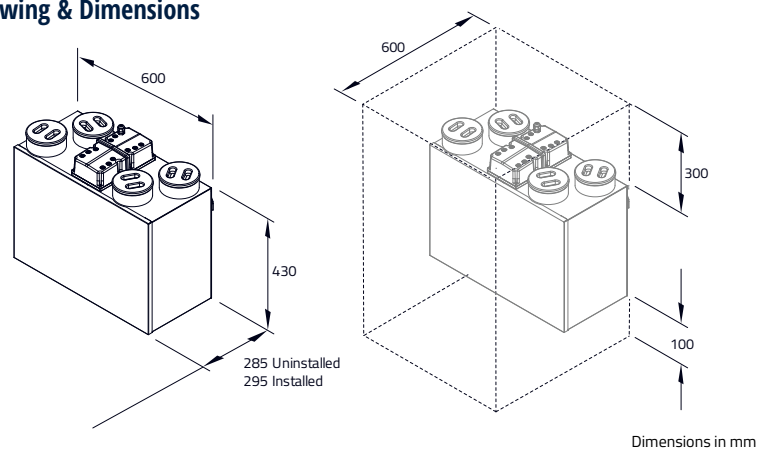

Performance

The figures and compliance levels below relate to current SAP requirements. Revised SAP guidance will have an effect on performance and up-to-date figures can be found on the relevant product page at www.titon.com.

Exhaust terminal configuration*	Fan speed setting	2009		2012	
		SFP (W/l/s)	Heat exchange efficiency (%)	SFP (W/l/s)	Heat exchange efficiency (%)
Kitchen + 1 additional wet room	100% variable	0.65	88%	0.75	87%
Kitchen + 2 additional wet rooms	100% variable	0.74	87%	0.97	85%
Kitchen + 3 additional wet rooms	100% variable	0.89	85%	1.28	85%
Kitchen + 4 additional wet rooms	100% variable	1.11	84%	1.66	84%
Kitchen + 5 additional wet rooms	100% variable	1.38	84%	-	-
Kitchen + 6 additional wet rooms	100% variable	1.65	84%	-	-

Figures taken from the BRE Test Results.

*Number of wet rooms is based on SAP Q test criteria and does not correlate directly with regulatory performance requirements.

Nominal Fan Performance

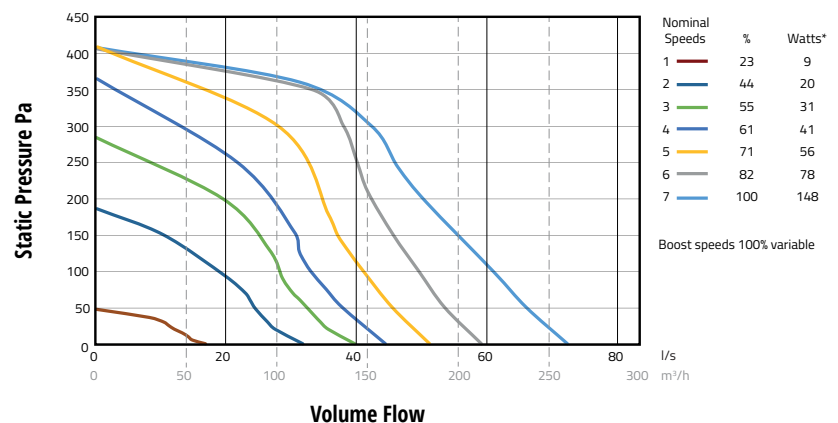

*@FID (0 Pa)

100% variable speed control. Performance curves for Eco version.

Acoustic Data

Product	% of Max flow	Airflow	dB(A) @ 3m Hemispherical			dB(A) @ 3m Spherical
			Induct Inlet	Induct Outlet	Casing Breakout	Casing Breakout
HRV1.3 Q Plus	30%	26l/s @ 18Pa	33	43	21	18
	65%	43l/s @ 45Pa	40	52	29	26
	100%	63l/s @ 100Pa	47	59	36	33

For full frequency acoustic data at various speeds please see www.titon.com. All acoustic data is third party tested at Sound Research Laboratories (SRL) Ltd.

HRV1.35 Q Plus

Ultra energy efficient Heat Recovery Ventilation unit

For use in small to medium sized dwellings

The enhanced capacity ultra compact HRV1.35 Q Plus continuously running whole-house ventilation unit with heat recovery is independently tested by the BRE and maintains an ultra compact size despite its improved airflow performance.

Combining extremely low power consumption and a highly efficient heat exchanger, this unit enhances SAP performance via Appendix Q, and yet remains versatile enough in size to be equally as functional in larger apartments as it is in small to medium sized dwellings.

Recognised and listed in the UK Product Characteristics Database and includes intelligent humidity options through controller options.

MVHR

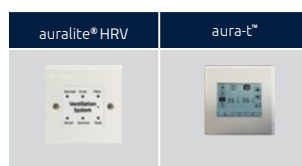

Features & Benefits

- Highly versatile compact unit
- Extremely low Specific Fan Power; down to 0.65 W/l/s
- Highly efficient heat exchanger; up to 88%
- Airflow up to 60l/s (217 m³/h) at 100 Pa
- Accepts 125mm diameter ducting, no adaptors required
- Intelligent frost protection, stepped reduction of supply air rates prevents HRV unit from freezing
- ISO Coarse 55% (G3) filters as standard with ISO Coarse 60% (G4) as an option
- Enthalpy Heat Cell option available
- Fully adjustable boost overrun timer 0-60 minutes; can be used with non-latching (momentary) switches to prevent unit from being accidentally left in boost mode
- Setback facility to reduce ventilation where local regulations allow
- Intelligent Summer Bypass and humidity controls
- Volt free switching control
- Intelligent controller, quick and easy to commission
- Lightweight for easy handling
- Quick fix mounting bracket
- IP32 rating
- On board aura-t™ option
- Patented
- Independent fan adjustment
- SUMMERboost® facility
- Effective in reducing pollutants in the home and improving Indoor Air Quality (IAQ), therefore reducing the risk of Toxic Home Syndrome
- Intelligent Summer Bypass & humidity controls
- SUMMERboost® facility
- Available in left and right handed configurations

Eco HMB Models:

- Compatible with auralite® HRV (TP518) status indicator and aura-t™ controller
- Fitted with removable filter covers on the front panel
- Standard - Volt free switching control
- Optional - Switch live control available with via Relay (TP505)

Eco B Models:

- Compatible with Eco-aura range; aurastat®, auramode® and aura-t™ controllers and auralite® HRV (TP519) status indicator
- Duct Pre-heater control (requires independent power supply)
- BMS compatible via RS485 (subject to limitations, additional software requirements and specification with any order)
- Standard - Volt Free switching and switch live control

Product Codes

HRV1.35 Q Plus HMB Eco auralite® & aura-t™ ready -
TP408HMB/544 (left hand config) or
TP408HMB/RH (right hand config) - Energy Rating A

HRV1.35 Q Plus B Eco-aura controls ready -
TP418B/LH (left hand config) or
TP418B/RH (right hand config) - Energy Rating A
TP418BF (Filter Door) - Energy Rating A
TP418BC (Cold Climate) - Energy Rating A

Filters:

XP40032/099 - ISO Coarse 55% (G3) filters fitted as standard (UK only).
XP46022/099 - ISO Coarse 60% (G4) filters fitted on request. (Europe fitted as standard).
XP2011094/099 - ISO Coarse 55% (G3)/ISO ePM1 50% (F7) filters available on request.
XP2011095/099 - ISO Coarse 60% (G4)/ISO ePM1 50% (F7) filters available on request.

Standards

Conforms to requirements of UK statutory Building Regulations and Technical Standards for Ventilation and BRE 398.

SAP Appendix Q tested.

Exceeds requirements of Building Regulations Approved Document L (England & Wales).

EU RoHS Directive compliant.

Conforms to requirements of EC council directives relating to Electromagnetic Compatibility and Electrical Safety:

2006/95/EC (LVD), 2004/108/EC (EMC)
 EN 60335-1:2002/A2:2006, EN 60335-2-80:2003/A1:2004.

CE and UKCA marked.

Specification

Dimensions: 600mm wide x 430mm high (excluding ports) x 285mm deep (295mm with mounting bracket)

Weight: 16kg

Finish: White Paint

Materials:

Housing: Zintec sheet steel housing, powder coated white

Internals: Expanded polypropylene (EPP)

Heat exchanger: Polystyrene

Internal insulation: Closed cell foamed

Nitrile rubber, class 'O' fire rating

Standard filters: Grade ISO Coarse 55% (G3) synthetic filters

Guarantee period: 3 years (UK only)

Electrical: 230V ~ 50/60Hz, 3A fuse

Installation: To be installed accordance with the relevant and applicable building regulations.

Maintenance: Service and filter clean/replacement subject to local environment - see product manual.

Acoustics: Full acoustic data available online www.titon.com/acoustics.

Drawing & Dimensions

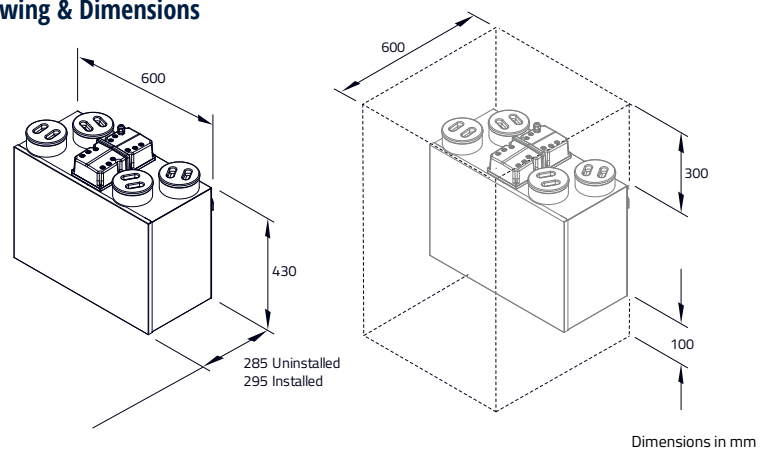

Performance

The figures and compliance levels below relate to current SAP requirements. Revised SAP guidance will have an effect on performance and up-to-date figures can be found on the relevant product page at www.titon.com.

Exhaust terminal configuration*	Fan speed setting	2009		2012	
		SFP (W/l/s)	Heat exchange efficiency (%)	SFP (W/l/s)	Heat exchange efficiency (%)
Kitchen + 1 additional wet room	100% variable	0.65	88%	0.71	87%
Kitchen + 2 additional wet rooms	100% variable	0.69	87%	0.92	85%
Kitchen + 3 additional wet rooms	100% variable	0.84	85%	1.19	85%
Kitchen + 4 additional wet rooms	100% variable	1.04	84%	1.55	84%
Kitchen + 5 additional wet rooms	100% variable	1.25	84%	-	-
Kitchen + 6 additional wet rooms	100% variable	1.53	84%	-	-

Figures taken from the BRE Test Results.

*Number of wet rooms is based on SAP Q test criteria and does not correlate directly with regulatory performance requirements.

Nominal Fan Performance

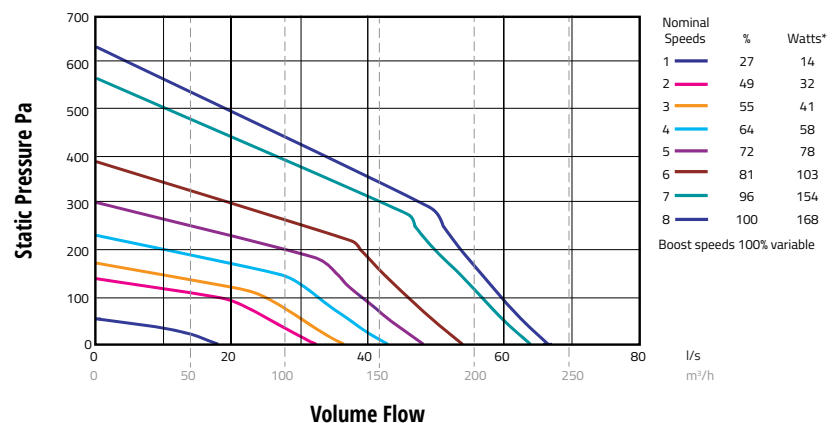

*@FID (0 Pa)

100% variable speed control. Performance curves for Eco version.

Acoustic Data

Product	% of Max flow	Airflow	dB(A) @ 3m Hemispherical			dB(A) @ 3m Spherical
			Induct Inlet	Induct Outlet	Casing Breakout	Casing Breakout
HRV1.35 Q Plus	37%	22l/s @ 12Pa	28	39	19	16
	65%	39l/s @ 38Pa	40	52	29	26
	100%	60l/s @ 100Pa	47	61	36	33

For full frequency acoustic data at various speeds please see www.titon.com. All acoustic data is third party tested at Sound Research Laboratories (SRL) Ltd.

HRV1.35 Q Plus - Enthalpy

Ultra energy efficient Heat Recovery Ventilation unit

For use in small to medium sized dwellings

The high capacity HRV1.35 Q Plus continuously running whole-house ventilation unit with heat recovery maintains an ultra compact size despite its improved airflow performance.

Combining extremely low power consumption and a highly efficient heat exchanger, this unit remains versatile enough in size to be equally as functional in larger apartments as it is in small to medium sized dwellings.

The counter flow enthalpy heat exchanger has a selective polymer membrane film to achieve low air leakage levels while providing moisture recovery from the exhaust air. These models are ideal for living areas with low humidity, avoiding frost build up at low temperatures, they also have an antimicrobial membrane and long life cycle.

MVHR

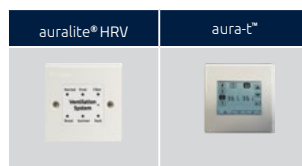

Features & Benefits

- Versatile compact unit
- Highly efficient enthalpy counter flow heat exchanger
- Airflow up to 66l/s (237 m³/h) at 100 Pa
- Accepts 100mm or 125mm diameter ducting, no adaptors required
- Intelligent frost protection
- ISO Coarse 55% (G3) filters as standard, ISO Coarse 60% (G4) as an option
- Fully adjustable boost overrun timer 0-60 minutes; can be used with non-latching (momentary) switches to prevent unit from being accidentally left in boost mode
- Setback facility to reduce ventilation where local regulations allow
- Intelligent Summer Bypass and humidity controls
- Volt free switching control
- Intelligent controller, quick and easy to commission
- Lightweight for easy handling
- Quick fix mounting bracket
- On board aura-t™ option
- Patented
- IP32 rating
- Independent fan adjustment
- SUMMERboost® facility
- Effective in reducing pollutants in the home and improving Indoor Air Quality (IAQ), therefore reducing the risk of Toxic Home Syndrome
- Available in left and right handed configurations

Eco BE Models:

- Compatible with Eco-aura range; aurastat®, auramode® and aura-t™ controllers and auralite® HRV (TP519) status indicator.
- Duct Pre-heater control (requires independent power supply)
- BMS compatible via RS485 (subject to limitations, additional software requirements and specification with any order)
- Standard - Volt Free switching and switch live control

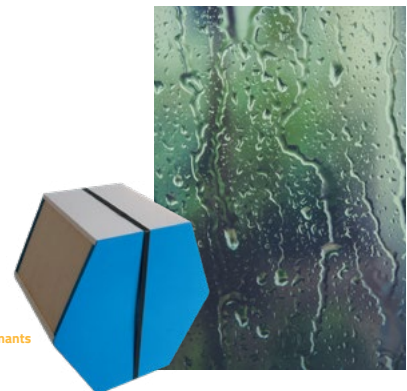
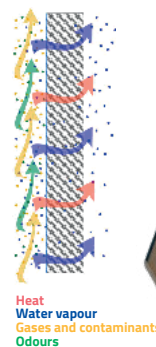

Product Codes

HRV1.35 Q Plus B Eco Enthalpy
Eco-aura controls ready -
TP418BE/LH (left hand config) or
TP418BE/RH (right hand config) - Energy Rating A

Filters:

XP40032/099 - ISO Coarse 55% (G3) filters fitted as standard (UK only).
XP46022/099 - ISO Coarse 60% (G4) filters fitted on request. (Europe fitted as standard).
XP2011094/099 - ISO Coarse 55% (G3)/ISO ePM1 50% (F7) filters available on request.
XP2011095/099 - ISO Coarse 60% (G4)/ISO ePM1 50% (F7) filters available on request.

Standards

EU RoHS Directive compliant.

Conforms to requirements of EC council directives relating to Electromagnetic Compatibility and Electrical Safety:

2006/95/EC (LVD), 2004/108/EC (EMC)
EN 60335-1:2002/A2:2006, EN 60335-2- 80:2003/A1:2004.

CE and UKCA marked.

Specification

Dimensions: 600mm wide x 430mm high (excluding ports) x 285mm deep (295mm with mounting bracket)

Weight: 18kg

Finish: White Paint

Materials:

Housing: Zintec sheet steel housing, powder coated white

Internals: Expanded polypropylene (EPP)

Heat exchanger: Selective polymer membrane film

Internal insulation: Closed cell foamed

Nitrile rubber, class 'O' fire rating

Standard filters: Grade ISO Coarse 55% (G3) synthetic filters

Guarantee period: 3 years (UK only)

Electrical: 230V ~ 50/60Hz, 3A fuse

Installation: To be installed accordance with the relevant and applicable building regulations.

Maintenance: Service and filter clean/replacement subject to local environment - see product manual.

Acoustics: Full acoustic data available online www.titon.com/acoustics.

Drawing & Dimensions

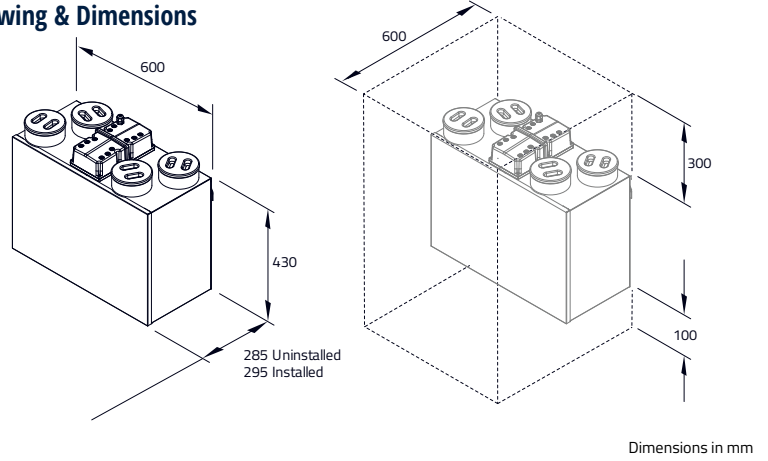

Heat Cell

Technical Data

(Typical conditions at 140 m³/h)

- Heat change rate 80%
- Degree of moisture change 70%
- Leakage at 100 Pa < 1%
- Temperature stability - 25°C up to 65°C

Features & Benefits

- No transfer of gases or pollutants - only heat and water vapour transferred by the membrane
- Long life cycle - permanent transmission parameters
- Minimum leakage
- Optimum flow behaviour, low pressure loss
- Frost- and heat-proof
- High, sensitive and latent transmission rate
- Antimicrobial (Microban® - integrated hygiene protection)
- Can be cleaned using water
- European manufactured heat cell

Nominal Fan Performance

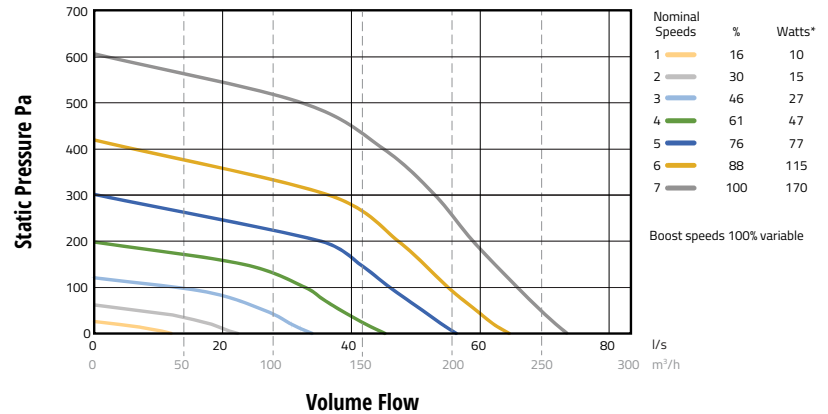

*@FID (0 Pa)
100% variable speed control. Performance curves for Eco version.

Acoustic Data

Product	Airflow	dB(A) @ 3m Hemispherical			dB(A) @ 3m Spherical
		Induct Inlet	Induct Outlet	Casing Breakout	Casing Breakout
HRV1.35 Q Plus Enthalpy	22l/s @ 12Pa	28	39	19	16
	39l/s @ 38Pa	40	52	29	26
	60l/s @ 100Pa	47	61	36	33

For full frequency acoustic data at various speeds please see www.titon.com. All acoustic data is third party tested at Sound Research Laboratories (SRL) Ltd.

HRV1.6 Q Plus

Ultra energy efficient Heat Recovery Ventilation unit

For use in medium to large sized dwellings

The enhanced capacity HRV1.6 Q Plus continuously running whole-house ventilation unit with heat recovery is independently tested by the BRE maintains an ultra compact size despite its improved results.

Combining extremely low power consumption and a highly efficient heat exchanger, this unit enhances SAP performance via Appendix Q, and yet remains versatile enough in size to be equally as functional in larger apartments as it is in medium to large sized dwellings.

Recognised and listed in the UK Product Characteristics Database and includes intelligent humidity options through controller options.

MVHR

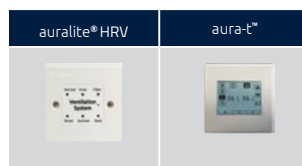
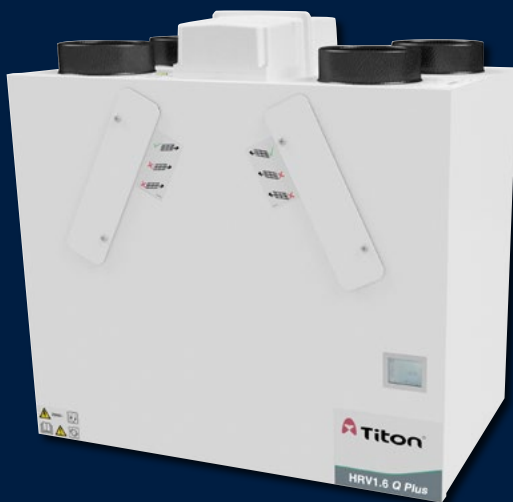

Features & Benefits

- Highly versatile compact unit
- Extremely low Specific Fan Power; down to 0.49 W/l/s
- Highly efficient heat exchanger; up to 89%
- Airflow up to 100l/s (359 m³/h) at 100 Pa
- Accepts 125mm ducting no adaptors required
- Intelligent frost protection, stepped reduction of supply air rates prevents HRV unit from freezing
- ISO Coarse 55% (G3) filters as standard with ISO Coarse 60% (G4) as an option
- Fully adjustable boost overrun timer 0-60 minutes; can be used with non-latching (momentary) switches to prevent unit from being accidentally left in boost mode
- Volt free switching control
- Intelligent controller, quick and easy to commission
- Lightweight for easy handling
- Quick fix mounting bracket
- IP32 rating
- On board aura-t™ option
- Patented
- Independent fan adjustment
- Effective in reducing pollutants in the home and improving Indoor Air Quality (IAQ), therefore reducing the risk of Toxic Home Syndrome
- Intelligent Summer Bypass & humidity controls
- SUMMERboost® facility
- Available in left and right handed configurations

Eco HMB Models:

- Compatible with auralite® HRV (TP518) status indicator and aura-t™ controller
- Fitted with removable filter covers on the front panel
- Standard - Volt free switching control
- Optional - Switch live control available with via Relay (TP505)

Eco B Models:

- Compatible with Eco-aura range; aurastat®, auramode® and aura-t™ controllers and auralite® HRV (TP519) status indicator
- Duct Pre-heater control (requires independent power supply)
- BMS compatible via RS485 (subject to limitations, additional software requirements and specification with any order)
- Standard - Volt Free switching and switch live control



Product Codes

HRV1.6 Q Plus HMB Eco auralite® & aura-t™ ready -
TP409HMB/544 (left hand config) or
TP409HMB/RH (right hand config) - Energy Rating A

HRV1.6 Q Plus B Eco-aura controls ready -
TP419B/LH (left hand config) or
TP419B/RH (right hand config) - Energy Rating A+
TP419BC (Cold Climate) - Energy Rating A+

Filters:

XP2010671/099 - ISO Coarse 55% (G3) filters fitted as standard (UK only).

XP2010897/099 - ISO Coarse 60% (G4) filters fitted on request (Europe fitted as standard).

XP2011096/099 - ISO Coarse 55% (G3)/ISO ePM1 50% (F7) filters available on request.

XP2011097/099 - ISO Coarse 60% (G4)/ISO ePM1 50% (F7) filters available on request.

Standards

Conforms to requirements of UK statutory Building Regulations and Technical Standards for Ventilation and BRE 398.

SAP Appendix Q tested

Exceeds requirements of Building Regulations Approved Document L (England & Wales).

EU RoHS Directive compliant.

Conforms to requirements of EC council directives relating to Electromagnetic Compatibility and Electrical Safety:
 2006/95/EC (LVD), 2004/108/EC (EMC)
 EN 60335-1:2002/A2:2006, EN 60335-2- 80:2003/A1:2004.

CE and UKCA marked.

Specification

Dimensions: 600mm wide x 505mm high (excluding ports) x 353mm deep (363mm with mounting bracket)

Weight: 22kg

Finish: White Paint

Materials:

Housing: Zintec sheet steel housing, powder coated white

Internals: Expanded polypropylene (EPP)

Heat exchanger: Polystyrene

Internal insulation: Closed cell foamed Nitrile rubber, class 'O' fire rating

Standard filters: Grade ISO Coarse 55% (G3) synthetic filters.

Guarantee period: 3 years (UK only)

Electrical: 230V ~ 50/60Hz, 3A fuse

Installation: To be installed accordance with the relevant and applicable building regulations.

Maintenance: Service and filter clean/replacement subject to local environment - see product manual.

Acoustics: Full acoustic data available online www.titon.com/acoustics.

Drawing & Dimensions

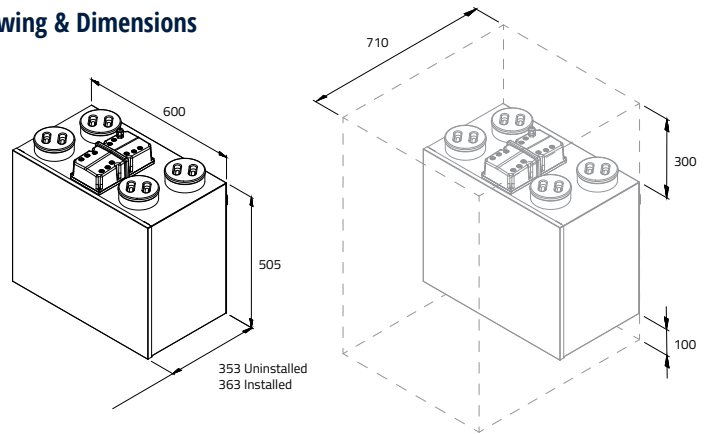

Dimensions in mm

Performance

The figures and compliance levels below relate to current SAP requirements. Revised SAP guidance will have an effect on performance and up-to-date figures can be found on the relevant product page at www.titon.com.

Exhaust terminal configuration*	Fan speed setting	2009		2012	
		SFP (W/l/s)	Heat exchange efficiency (%)	SFP (W/l/s)	Heat exchange efficiency (%)
Kitchen + 1 additional wet room	100% variable	0.49	89%	0.51	89%
Kitchen + 2 additional wet rooms	100% variable	0.49	89%	0.58	87%
Kitchen + 3 additional wet rooms	100% variable	0.53	87%	0.7	86%
Kitchen + 4 additional wet rooms	100% variable	0.63	86%	0.9	84%
Kitchen + 5 additional wet rooms	100% variable	0.75	85%	1.07	83%
Kitchen + 6 additional wet rooms	100% variable	0.87	84%	1.34	82%
Kitchen + 7 additional wet rooms	100% variable	1.03	83%	-	-

Figures taken from the BRE Test Results.

*Number of wet rooms is based on SAP Q test criteria and does not correlate directly with regulatory performance requirements.

Nominal Fan Performance

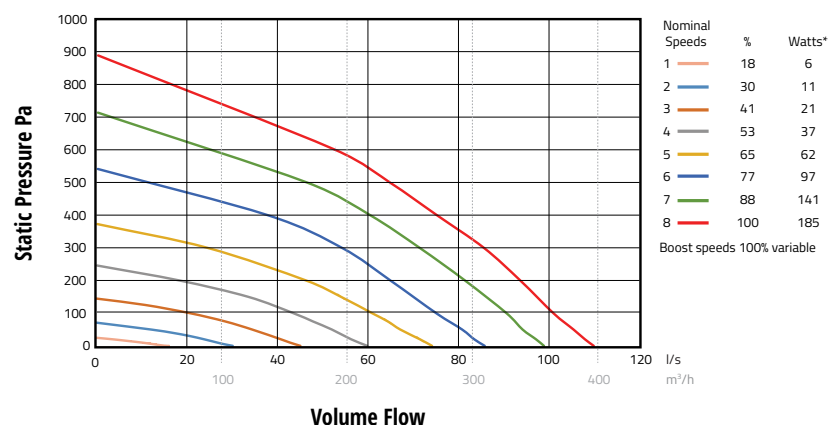

*@FID (0 Pa)

100% variable speed control. Performance curves for Eco version.

Acoustic Data

Product	% of Max flow	Airflow	dB(A) @ 3m Hemispherical			dB(A) @ 3m Spherical
			Induct Inlet	Induct Outlet	Casing Breakout	Casing Breakout
HRV1.6 Q Plus	41%	44l/s @ 17Pa	33	42	18	15
	65%	71l/s @ 45Pa	44	50	30	27
	100%	98l/s @ 100Pa	54	63	43	40

For full frequency acoustic data at various speeds please see www.titon.com. All acoustic data is third party tested at Sound Research Laboratories (SRL) Ltd.

HRV1.6 Q Plus - Enthalpy

Ultra energy efficient Heat Recovery Ventilation unit

For use in medium to large sized dwellings

The high capacity HRV1.6 Q Plus continuously running whole-house ventilation unit with heat recovery maintains an ultra compact size despite its improved airflow performance.

Combining extremely low power consumption and a highly efficient heat exchanger, this unit remains versatile enough in size to be equally as functional in large apartments as it is in medium to large sized dwellings.

The counter flow enthalpy heat exchanger has a selective polymer membrane film to achieve low air leakage levels while providing moisture recovery from the exhaust air. These models are ideal for living areas with low humidity, avoiding frost build up at low temperatures, they also have an antimicrobial membrane and long life cycle.

Recognised and listed in the UK Product Characteristics Database and includes intelligent humidity options through controller options.

MVHR

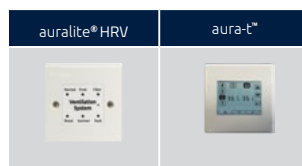

Features & Benefits

- Versatile compact unit
- Highly efficient enthalpy counter flow heat exchanger
- Airflow up to 88l/s (317 m³/h) at 100 Pa
- Accepts 100mm or 125mm diameter ducting, no adaptors required
- Intelligent frost protection
- ISO Coarse 55% (G3) filters as standard, ISO Coarse 60% (G4) as an option
- Fully adjustable boost overrun timer 0-60 minutes; can be used with non-latching (momentary) switches to prevent unit from being accidentally left in boost mode
- Setback facility to reduce ventilation where local regulations allow
- Intelligent Summer Bypass and humidity controls
- Volt free switching control
- Intelligent controller, quick and easy to commission
- Lightweight for easy handling
- Quick fix mounting bracket
- IP32 rating
- On board aura-t™ option
- Patented
- Independent fan adjustment
- SUMMERboost® facility
- Effective in reducing pollutants in the home and improving Indoor Air Quality (IAQ), therefore reducing the risk of Toxic Home Syndrome
- Available in left and right handed configurations

Eco BE Models:

- Compatible with Eco-aura range; aurastat®, auramode® and aura-t™ controllers and auralite® HRV (TP519) status indicator.
- Duct Pre-heater control (requires independent power supply)
- BMS compatible via RS485 (subject to limitations, additional software requirements and specification with any order)
- Standard - Volt Free switching and switch live control

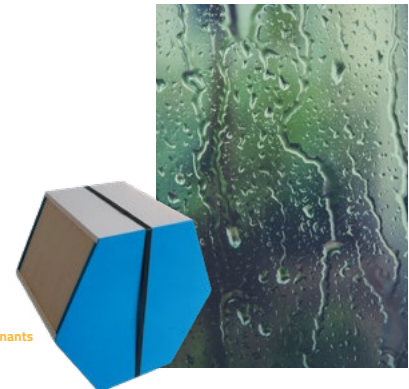
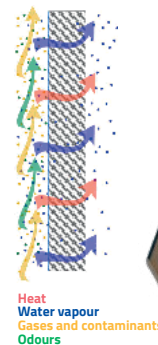

Product Codes

HRV1.6 Q Plus BE Eco Enthalpy Eco-aura controls ready - (Filter Door)

TP429BE/LH (left hand config) or

TP429BE/RH (right hand config) - Energy Rating A+

Filters:

XP2010671/099 - ISO Coarse 55% (G3) filters fitted as standard (UK only).

XP2010897/099 - ISO Coarse 60% (G4) filters fitted on request (Europe fitted as standard).

XP2011096/099 - ISO Coarse 55% (G3)/ISO ePM1 50% (F7) filters available on request.

XP2011097/099 - ISO Coarse 60% (G4)/ISO ePM1 50% (F7) filters available on request.

Standards

EU RoHS Directive compliant.

Conforms to requirements of EC council directives relating to Electromagnetic Compatibility and Electrical Safety:

2006/95/EC (LVD), 2004/108/EC (EMC)

EN 60335-1:2002/A2:2006, EN 60335-2-80:2003/A1:2004.

CE and UKCA marked.

Specification

Dimensions: 600mm wide x 505mm high (excluding ports) x 353mm deep (363mm with mounting bracket)

Weight: 25kg

Finish: White Paint

Materials:

Housing: Zintec sheet steel housing, powder coated white

Internals: Expanded polypropylene (EPP)

Heat exchanger: Selective polymer membrane film

Internal insulation: Closed cell foamed

Nitrile rubber, class 'O' fire rating

Standard filters: Grade ISO Coarse 55% (G3) synthetic filters

Guarantee period: 3 years (UK only)

Electrical: 230V ~ 50/60Hz, 3A fuse

Installation: To be installed accordance with the relevant and applicable building regulations.

Maintenance: Service and filter clean/replacement subject to local environment - see product manual.

Acoustics: Full acoustic data available online www.titon.com/acoustics.

Drawing & Dimensions

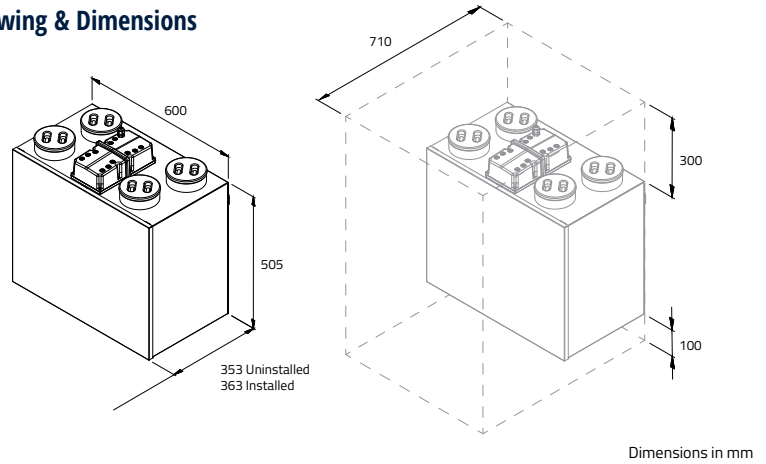

Heat Cell

Technical Data

(Typical conditions at 140 m³/h)

- Heat change rate 80%
- Degree of moisture change 70%
- Leakage at 100 Pa < 1%
- Temperature stability - 25°C up to 65°C

Features & Benefits

- No transfer of gases or pollutants - only heat and water vapour transferred by the membrane
- Long life cycle - permanent transmission parameters
- Minimum leakage
- Optimum flow behaviour, low pressure loss
- Frost- and heat-proof
- High, sensitive and latent transmission rate
- Antimicrobial (Microban® - integrated hygiene protection)
- Can be cleaned using water
- European manufactured heat cell

Nominal Fan Performance

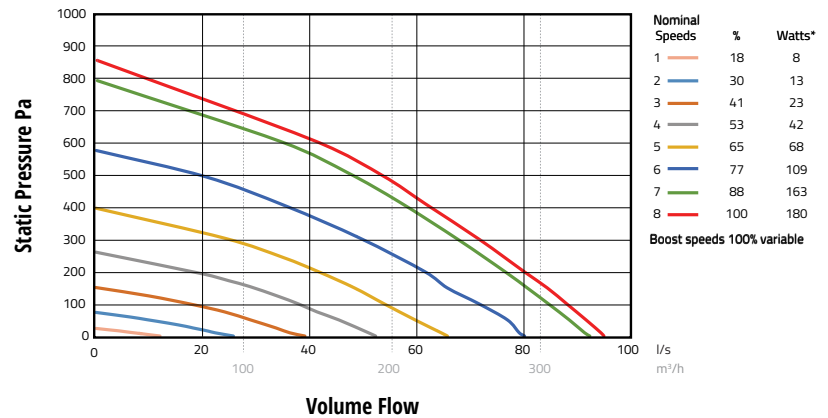

*@FID (0 Pa)

100% variable speed control. Performance curves for Eco version.

Acoustic Data

Product	% of Max flow	Airflow	dB(A) @ 3m Hemispherical			dB(A) @ 3m Spherical
			Induct Inlet	Induct Outlet	Casing Breakout	Casing Breakout
HRV1.6 Q Plus Enthalpy	41%	35l/s @ 17Pa	33	42	18	15
	65%	60l/s @ 54Pa	44	50	30	27
	100%	88l/s @ 100Pa	54	63	43	40

For full frequency acoustic data at various speeds please see www.titon.com. All acoustic data is third party tested at Sound Research Laboratories (SRL) Ltd.

HRV1.65 Q Plus

Ultra energy efficient Heat Recovery Ventilation unit

For use in medium to large sized dwellings

The enhanced capacity HRV1.65 Q Plus continuously running whole-house ventilation unit with heat recovery is independently tested by the BRE maintains an ultra compact size despite its improved results.

Combining extremely low power consumption and a highly efficient heat exchanger, the HRV1.65 Q Plus is specifically designed to enhance SAP performance via Appendix Q, yet still small enough to be easily incorporated into medium or large sized dwellings.

Recognised and listed in the UK Product Characteristics Database and includes intelligent humidity options through controller options.

MVHR

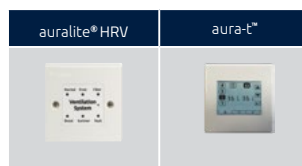

Features & Benefits

- Highly versatile compact unit
- Extremely low Specific Fan Power; down to 0.43 W/l/s
- Highly efficient heat exchanger; up to 89%
- Airflow up to 96l/s (344 m³/h) at 100 Pa
- Accepts 125mm ducting no adaptors required
- Intelligent frost protection, stepped reduction of supply air rates prevents HRV unit from freezing
- ISO Coarse 55% (G3) filters as standard with ISO Coarse 60% (G4) as an option
- Fully adjustable boost overrun timer 0-60 minutes; can be used with non-latching (momentary) switches to prevent unit from being accidentally left in boost mode
- Volt free switching control
- Intelligent controller, quick and easy to commission
- Lightweight for easy handling
- Quick fix mounting bracket
- IP32 rating
- On board aura-t™ option
- Patented
- Independent fan adjustment
- Effective in reducing pollutants in the home and improving Indoor Air Quality (IAQ), therefore reducing the risk of Toxic Home Syndrome
- Intelligent Summer Bypass & humidity controls
- SUMMERboost® facility
- Available in left and right handed configurations

Eco HMB Models:

- Compatible with auralite® HRV (TP518) status indicator and aura-t™ controller
- Fitted with removable filter covers on the front panel
- Standard - Volt free switching control
- Optional - Switch live control available with via Relay (TP505)

Eco B Models:

- Compatible with Eco-aura range; aurastat®, auramode® and aura-t™ controllers and auralite® HRV (TP519) status indicator
- Duct Pre-heater control (requires independent power supply)
- BMS compatible via RS485 (subject to limitations, additional software requirements and specification with any order)
- Standard - Volt Free switching and switch live control

Product Codes

HRV1.65 Q Plus HMB Eco auralite® & aura-t™ ready -
TP410HMB/544 (left hand config) or
TP410HMB/RH (right hand config) - Energy Rating A

HRV1.65 Q Plus B Eco-aura controls ready -
TP420B/LH (left hand config) or
TP420B/RH (right hand config) - Energy Rating A

Filters:

XP2010671/099 - ISO Coarse 55% (G3) filters fitted as standard (UK only).

XP2010897/099 - ISO Coarse 60% (G4) filters fitted on request (Europe fitted as standard).

XP2011096/099 - ISO Coarse 55% (G3)/ISO ePM1 50% (F7) filters available on request.

XP2011097/099 - ISO Coarse 60% (G4)/ISO ePM1 50% (F7) filters available on request.

Standards

Conforms to requirements of UK statutory Building Regulations and Technical Standards for Ventilation and BRE 398.

SAP Appendix Q tested

Exceeds requirements of Building Regulations Approved Document L (England & Wales).

EU RoHS Directive compliant.

Conforms to requirements of EC council directives relating to Electromagnetic Compatibility and Electrical Safety:

2006/95/EC (LVD), 2004/108/EC (EMC)
 EN 60335-1:2002/A2:2006, EN 60335-2- 80:2003/A1:2004.

CE and UKCA marked.

Specification

Dimensions: 600mm wide x 505mm high (excluding ports) x 353mm deep (363mm with mounting bracket)

Weight: 22kg

Finish: White Paint

Materials:

Housing: Zintec sheet steel housing, powder coated white

Internals: Expanded polypropylene (EPP)

Heat exchanger: Polystyrene

Internal insulation: Closed cell foamed Nitrile rubber, class '0' fire rating

Standard filters: Grade ISO Coarse 55% (G3) synthetic filters.

Guarantee period: 3 years (UK only)

Electrical: 230V ~ 50/60Hz, 3A fuse

Installation: To be installed accordance with the relevant and applicable building regulations.

Maintenance: Service and filter clean/replacement subject to local environment - see product manual.

Acoustics: Full acoustic data available online www.titon.com/acoustics.

Drawing & Dimensions

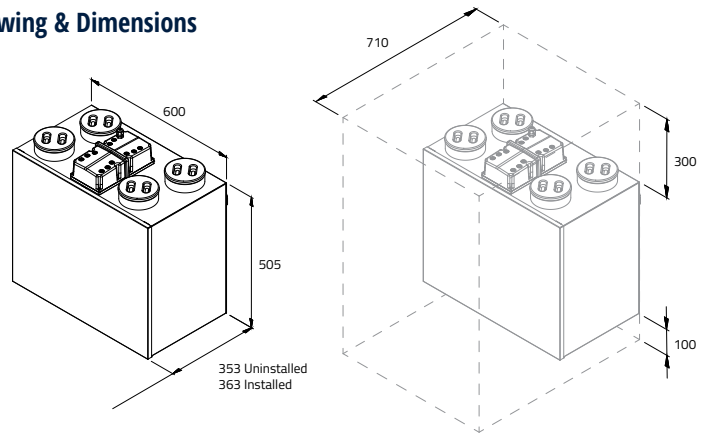

Dimensions in mm

Performance

The figures and compliance levels below relate to current SAP requirements. Revised SAP guidance will have an effect on performance and up-to-date figures can be found on the relevant product page at www.titon.com.

Exhaust terminal configuration*	Fan speed setting	2009		2012	
		SFP (W/l/s)	Heat exchange efficiency (%)	SFP (W/l/s)	Heat exchange efficiency (%)
Kitchen + 1 additional wet room	100% variable	0.44	89	0.46	89
Kitchen + 2 additional wet rooms	100% variable	0.43	89	0.54	87
Kitchen + 3 additional wet rooms	100% variable	0.50	87	0.65	86
Kitchen + 4 additional wet rooms	100% variable	0.59	86	0.84	84
Kitchen + 5 additional wet rooms	100% variable	0.70	85	1.05	83
Kitchen + 6 additional wet rooms	100% variable	0.83	84	1.27	82
Kitchen + 7 additional wet rooms	100% variable	1.00	83	-	-

Figures taken from the BRE Test Results.

*Number of wet rooms is based on SAP Q test criteria and does not correlate directly with regulatory performance requirements.

Nominal Fan Performance

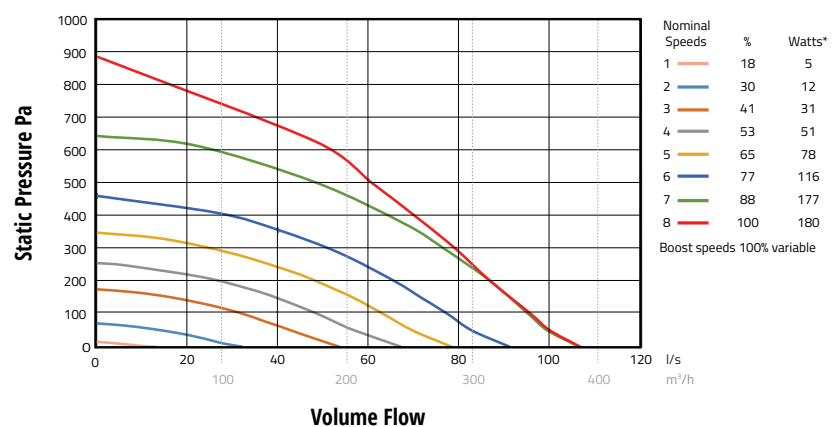

*@FID (0 Pa)

100% variable speed control. Performance curves for Eco version.

Acoustic Data

Product	% of Max flow	Airflow	dB(A) @ 3m Hemispherical			dB(A) @ 3m Spherical
			Induct Inlet	Induct Outlet	Casing Breakout	Casing Breakout
HRV1.65 Q Plus	41%	52l/s @ 28Pa	42	49	25	22
	65%	75l/s @ 52Pa	48	56	34	31
	100%	99l/s @ 100Pa	54	67	47	44

For full frequency acoustic data at various speeds please see www.titon.com. All acoustic data is third party tested at Sound Research Laboratories (SRL) Ltd.

HRV4 Q Plus

Ultra energy efficient Heat Recovery Ventilation unit

For use in medium to large sized dwellings

Introducing the new HRV4 Q Plus: a powerful yet compact, continuously running whole-house ventilation unit with heat recovery. It is suitable for larger dwellings and has been independently tested by the BRE. The HRV4 Q Plus delivers cutting-edge performance usually only associated with much larger and more expensive products.

The combination of very low power consumption and a highly efficient heat exchanger is specifically designed to enhance SAP performance via Appendix Q, yet small enough to be easily incorporated into medium sized dwellings.

Recognised and listed in the UK Product Characteristics Database and includes intelligent humidity options through controller options.

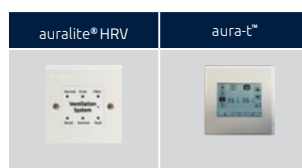
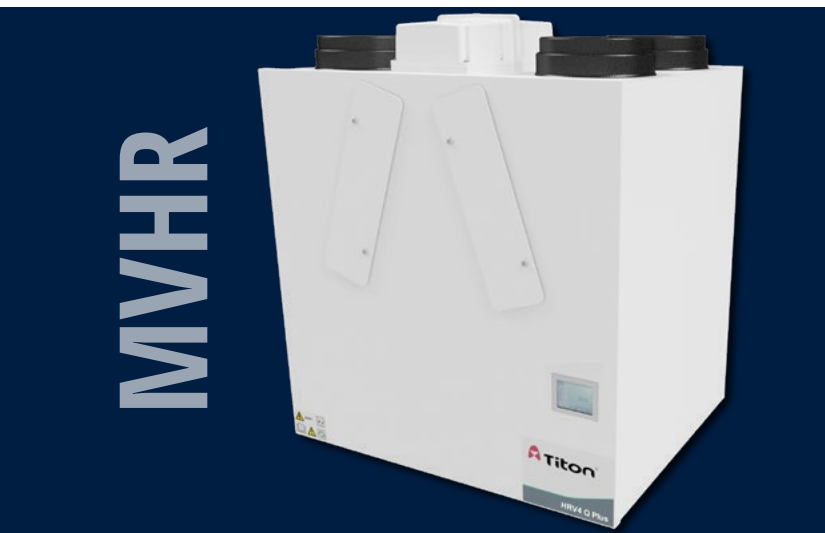

Features & Benefits

- Extremely low Specific Fan Power; down to 0.38 W/l/s
- Highly efficient heat exchanger; up to 91%
- Airflow up to 118 l/s (425 m³/h) at 100 Pa
- Intelligent controller, quick and easy to commission
- Fully adjustable boost overrun timer 0-60 minutes; use with non-latching (momentary) switches to prevent unit from being accidentally left in boost mode
- Accepts 150mm and 160mm diameter ducting, no adaptors required
- Intelligent frost protection (B2 and HMB), stepped reduction of supply air rates prevents HRV unit from freezing (B2 model only)
- Setback facility to reduce ventilation where local regulations allow
- ISO Coarse 85% (G4) filters as standard
- Quick fix mounting bracket
- IP32 rating
- Patented
- Independent fan adjustment
- Effective in reducing pollutants in the home and improving Indoor Air Quality (IAQ), therefore reducing
- Intelligent Summer Bypass & humidity controls
- SUMMERboost[®] facility

Eco HMB Models:

- aura-t[™] controller available as standalone only
- Fitted with removable filter covers on the front panel

Eco B2 Models:

- aura-t[™] onboard as standard
- Front panel; drop down filter flap panel or removable filter covers option available
- WiFi compatibility with aura-t SMART (WiFi) controller
- On site configured to either a LH or RH
- Full MODBUS connectivity
- BMS compatible via RS485 (subject to limitations, additional software requirements and specification with any order)
- Low voltage switching (x 3) and live switch (x 2)
- 4 x 0-10v proportional inputs for local demand control room sensors
- Duct Pre-heater control (requires independent power supply)

Product Codes

HRV4 Q Plus Eco HMB aura-t™ ready -
TP421HMB/544 (left hand config) or
TP421HMB/RH (right hand config) - Energy Rating A
 Fitted with removable filter covers on the front panel

HRV4 Q Plus B2 aura-t™ control -
TP431B2/LR-T* (LH/RH on site configuration)
 Fitted with removable filter covers on the front panel
TP431B2F/LR-T* (LH/RH on site configuration)
 Fitted with drop down filter flap panel
 - Energy Rating A+
 *Standard supply always LH

Filters:
 ISO Coarse 85% (G4) filters fitted as standard.

Standards

Conforms to requirements of UK statutory Building Regulations and Technical Standards for Ventilation and BRE 398.

SAP Appendix Q tested.

Exceeds requirements of Building Regulations Approved Document L (England & Wales).

EU RoHS Directive compliant.

Conforms to requirements of EC council directives relating to Electromagnetic Compatibility and Electrical Safety:
 2006/95/EC (LVD), 2004/108/EC (EMC), EN 60335-1:2002/A2:2006, EN 60335-2-80:2003/A1:2004.

CE and UKCA marked.

Specification

Dimensions: 600mm wide x 602mm high (excluding ports) x 477mm deep (487mm with mounting bracket)
Weight: 28.5kg

Finish: White Paint (RAL9016 Semi-gloss Traffic White)

Materials:

Housing: Zintec sheet steel housing, powder coated white

Internals: Expanded polypropylene (EPP)

Heat exchanger: Made from high quality PET materials
 Internal insulation: Closed cell foamed Nitrile rubber, class 'O' fire rating

Standard filters: Grade ISO Coarse 85% (G4) synthetic filters.

Guarantee period: 3 years (UK only)

Electrical: 230V ~ 50/60Hz, 5A fuse

Installation: To be installed accordance with the relevant and applicable building regulations.

Maintenance: Service and filter clean/replacement subject to local environment - see product manual.

Acoustics: Full acoustic data available online www.titon.com/acoustics.

Drawing & Dimensions

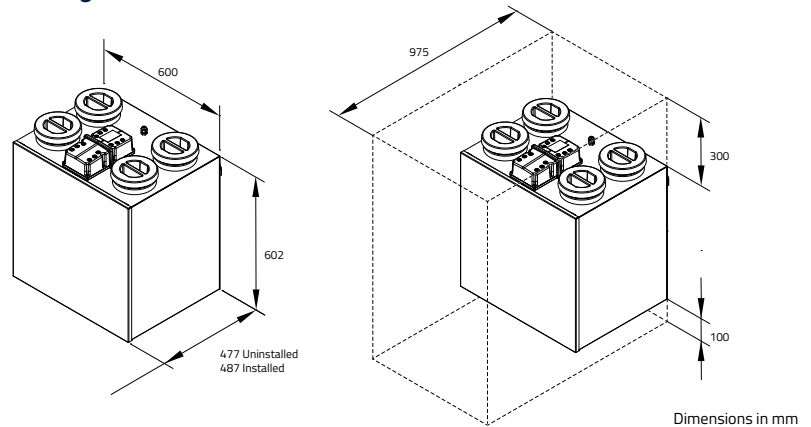

Performance

The figures and compliance levels below relate to current SAP requirements. Revised SAP guidance will have an effect on performance and up-to-date figures can be found on the relevant product page at www.titon.com.

Exhaust terminal configuration*	Fan speed setting	2009		2012		10	
		SFP (W/l/s)	Heat exchange efficiency (%)	SFP (W/l/s)	Heat exchange efficiency (%)	SFP (W/l/s)	Heat exchange efficiency (%)
Kitchen + 1 additional wet room	100% variable	0.41	91%	0.42	91%	0.42	91%
Kitchen + 2 additional wet rooms	100% variable	0.38	91%	0.43	90%	0.43	90%
Kitchen + 3 additional wet rooms	100% variable	0.4	90%	0.5	89%	0.5	89%
Kitchen + 4 additional wet rooms	100% variable	0.45	89%	0.6	88%	0.6	88%
Kitchen + 5 additional wet rooms	100% variable	0.51	89%	0.73	87%	0.73	87%
Kitchen + 6 additional wet rooms	100% variable	0.58	88%	0.9	86%	0.9	86%
Kitchen + 7 additional wet rooms	100% variable	0.7	87%	1.08	86%	1.08	86%

Figures taken from the BRE Test Results.

*Number of wet rooms is based on SAP Q test criteria and does not correlate directly with regulatory performance requirements.

Nominal Fan Performance

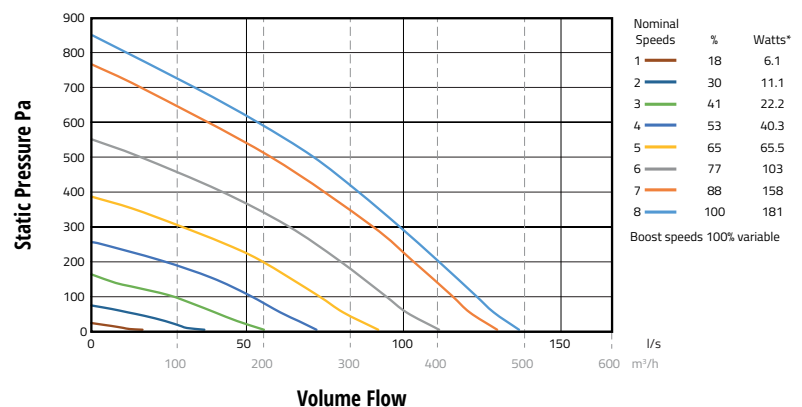

*@FID (0 Pa)

100% variable speed control. Performance curves for Eco version.

Acoustic Data

Product	% of Max flow	Airflow	dB(A) @ 3m Hemispherical			dB(A) @ 3m Spherical
			Induct Inlet	Induct Outlet	Casing Breakout	Casing Breakout
HRV4 Q Plus	41%	47.9l/s @ 15Pa	29	37	21	18
	65%	80.4l/s @ 41Pa	38	50	31	28
	100%	123.1l/s @ 100Pa	46	58	41	38

For full frequency acoustic data at various speeds please see www.titon.com. All acoustic data is third party tested at Sound Research Laboratories (SRL) Ltd.

HRV4.25 Q Plus

Ultra energy efficient Heat Recovery Ventilation unit

For use in medium to large sized dwellings

Introducing the new HRV4.25 Q Plus: a powerful yet compact, continuously running whole-house ventilation unit with heat recovery. It is suitable for larger dwellings and has been independently tested by the BRE. The HRV4.25 Q Plus delivers cutting-edge performance usually only associated with much larger and more expensive products.

The combination of very low power consumption and a highly efficient heat exchanger is specifically designed to enhance SAP performance via Appendix Q, yet small enough to be easily incorporated into medium sized dwellings.

Recognised and listed in the UK Product Characteristics Database and includes intelligent humidity options through controller options.

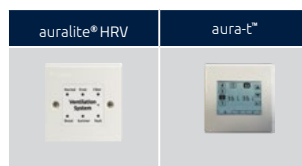
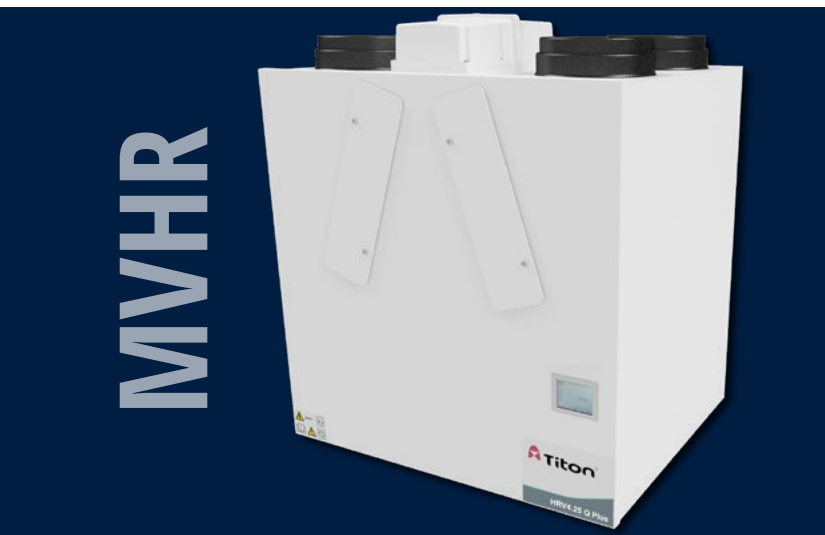

Features & Benefits

- Extremely low Specific Fan Power; down to 0.43 W/l/s
- Highly efficient heat exchanger; up to 91%
- Airflow up to 158 l/s (568 m³/h) at 100 Pa
- Intelligent controller, quick and easy to commission
- Fully adjustable boost overrun timer 0-60 minutes; use with non-latching (momentary) switches to prevent unit from being accidentally left in boost mode
- Accepts 150mm diameter ducting, no adaptors required
- Intelligent frost protection, stepped reduction of supply air rates prevents HRV unit from freezing
- Setback facility to reduce ventilation where local regulations allow
- ISO Coarse 85% (G4) filters as standard
- Quick fix mounting bracket
- IP32 rating
- Patented
- Independent fan adjustment
- Effective in reducing pollutants in the home and improving Indoor Air Quality (IAQ), therefore reducing
- Intelligent Summer Bypass & humidity controls
- SUMMERboost® facility

Eco HMB Models:

- Compatible with auralite® HRV (TP518) status indicator and aura-t™ controller
- aura-t™ controller available as standalone only
- Fitted with removable filter covers on the front panel

Eco B2 Models:

- aura-t™ onboard as standard
- Front panel; filter flap panel or removable filter covers option available
- On site configured to either a LH or RH
- Full MODBUS connectivity
- BMS compatible via RS485 (subject to limitations, additional software requirements and specification with any order)
- Low voltage switching (x 3) and live switch (x 2)
- 4 x 0-10v proportional inputs for local demand control room sensors
- Duct Pre-heater control (requires independent power supply)



Product Codes

HRV4.25 Q Plus Eco HMB aura-t™ ready -
TP423HMB/544 (left hand config) or
TP423HMB/RH (right hand config) - Energy Rating A
 Fitted with removable filter covers on the front panel

HRV4.25 Q Plus B2 aura-t™ control -
TP433B2/LR-T* (LH/RH on site configuration)
 Fitted with removable filter covers on the front panel
TP433B2F/LR-T* (LH/RH on site configuration)
 Fitted with drop down filter flap panel

- Energy Rating A
 *Standard supply always LH

Filters:
 ISO Coarse 85% (G4) filters fitted as standard.

Standards

Conforms to requirements of UK statutory Building Regulations and Technical Standards for Ventilation and BRE 398.

SAP Appendix Q tested.

Exceeds requirements of Building Regulations Approved Document L (England & Wales).

EU RoHS Directive compliant.

Conforms to requirements of EC council directives relating to Electromagnetic Compatibility and Electrical Safety:

2006/95/EC (LVD), 2004/108/EC (EMC)
 EN 60335-1:2002/A2:2006, EN 60335-2- 80:2003/A1:2004.

CE and UKCA marked.

Specification

Dimensions: 600mm wide x 602mm high (excluding ports) x 477mm deep (487mm with mounting bracket)

Weight: 28.5kg

Finish: White Paint (RAL9016 Semi-gloss Traffic White)

Materials:

Housing: Zintec sheet steel housing, powder coated white

Internals: Expanded polypropylene (EPP)

Heat exchanger: Made from high quality PET materials

Internal insulation: Closed cell foamed Nitrile rubber, class 'O' fire rating

Standard filters: Grade ISO Coarse 85% (G4) synthetic filters.

Guarantee period: 3 years (UK only)

Electrical: 230V ~ 50/60Hz, 5A fuse

Installation: To be installed accordance with the relevant and applicable building regulations.

Maintenance: Service and filter clean/replacement subject to local environment - see product manual.

Acoustics: Full acoustic data available online www.titon.com/acoustics.

Drawing & Dimensions

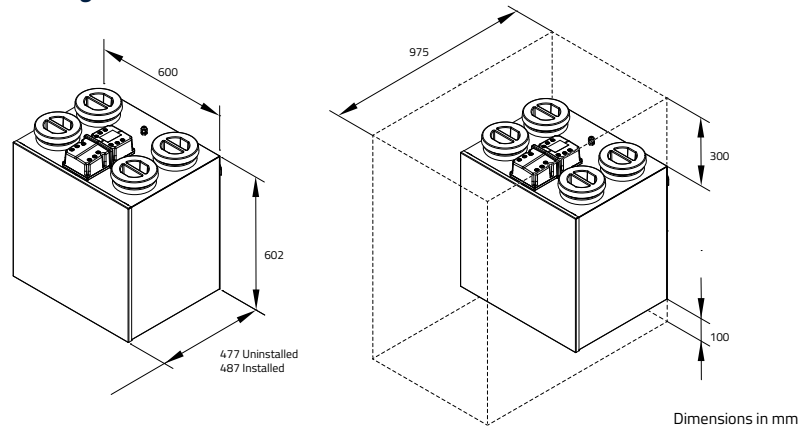

Performance

The figures and compliance levels below relate to current SAP requirements. Revised SAP guidance will have an effect on performance and up-to-date figures can be found on the relevant product page at www.titon.com.

Exhaust terminal configuration*	Fan speed setting	2009		2012		10	
		SFP (W/l/s)	Heat exchange efficiency (%)	SFP (W/l/s)	Heat exchange efficiency (%)	SFP (W/l/s)	Heat exchange efficiency (%)
Kitchen + 1 additional wet room	100% variable	0.46	91%	0.46	91%	0.46	91%
Kitchen + 2 additional wet rooms	100% variable	0.43	91%	0.43	91%	0.43	91%
Kitchen + 3 additional wet rooms	100% variable	0.44	90%	0.44	90%	0.44	90%
Kitchen + 4 additional wet rooms	100% variable	0.49	89%	0.49	89%	0.49	89%
Kitchen + 5 additional wet rooms	100% variable	0.55	89%	0.55	89%	0.55	89%
Kitchen + 6 additional wet rooms	100% variable	0.63	88%	0.63	88%	0.63	88%
Kitchen + 7 additional wet rooms	100% variable	0.73	87%	0.73	87%	0.73	87%

Figures taken from the BRE Test Results.

*Number of wet rooms is based on SAP Q test criteria and does not correlate directly with regulatory performance requirements.

Nominal Fan Performance

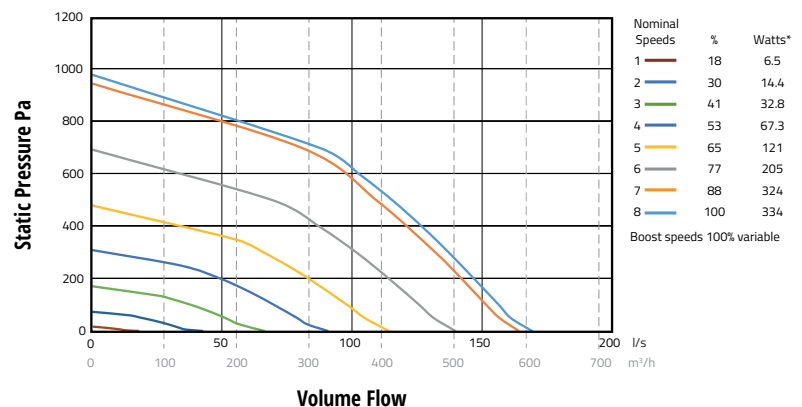

*@FID (0 Pa)
 100% variable speed control. Performance curves for Eco version.

Acoustic Data

Product	% of Max flow	Airflow	dB(A) @ 3m Hemispherical			dB(A) @ 3m Spherical
			Induct Inlet	Induct Outlet	Casing Breakout	Casing Breakout
HRV4.25 Q Plus	41%	57.8l/s @ 15Pa	41	45	27	24
	65%	104l/s @ 46Pa	44	56	36	33
	100%	157.8l/s @ 100Pa	50	64	47	44

For full frequency acoustic data at various speeds please see www.titon.com. All acoustic data is third party tested at Sound Research Laboratories (SRL) Ltd.

HRV20 HE Q Plus

Ultra energy efficient Heat Recovery Ventilation unit

For use in large sized dwellings

The new HRV20 HE Q Plus continuously running whole-house ventilation unit with heat recovery has been specifically designed to expand Titon's current HRV range by offering airflows of up to 178l/s (640 m³/h).

Combining extremely low power consumption and a highly efficient heat exchanger (up to 92%) specifically designed to enhance SAP performance via Appendix Q and can be incorporated into larger apartments or dwellings.

Recognised and listed in the UK Product Characteristics Database and includes intelligent humidity options through controller options.

MVHR

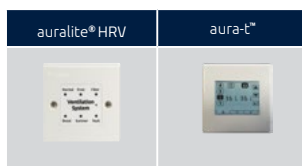

Features & Benefits

- Highly versatile compact unit
- Extremely low Specific Fan Power of 0.48 W/l/s
- Highly efficient heat exchanger; up to 92%
- Airflow up to 178l/s (640 m³/h) at 100 Pa
- Accepts 200mm diameter ducting
- Intelligent frost protection, stepped reduction of supply air rates prevents HRV unit from freezing
- ISO Coarse 65% (G4) bypass filter set fitted as standard. ISO Coarse 65% (G4)/ISO ePM1 75% (F7) available on request.
- Fully adjustable boost overrun timer 0-60 minutes; can be used with non-latching (momentary) switch to prevent unit from being accidentally left in boost mode
- Volt free switching control
- Intelligent controller, quick and easy to commission
- aura-t™ fitted on board as standard for HMB models and optional for B models
- Quick fix mounting bracket
- IP33 rating
- Patented
- Independent fan adjustment
- Effective in reducing pollutants in the home and improving Indoor Air Quality (IAQ), therefore reducing the risk of Toxic Home Syndrome
- Available in left and right handed configurations
- Intelligent Summer Bypass & humidity controls
- SUMMERboost® facility

Eco HMB Models:

- Fitted with aura-t™ controller on board as standard

Eco B Models:

- Compatible with Eco-aura range; aurastat®, auramode® and aura-t™ controllers and auralite® HRV (TP519) status indicator
- Duct heater control (requires independent power supply)
- BMS compatible via RS485 (subject to limitations, additional software requirements and specification with any order)
- Low voltage switching (x 3) and live switch (x 2)
- 4 x 0-10v proportional inputs for local demand control room sensors

Product Codes

HRV20 HE Q Plus HMB Eco aura-t™ ready -
TP652HMB/544 - (left hand config) or
TP652HMB/RH - (right hand config) - Energy Rating A
 Fitted with drop down filter flap panel

HRV20 HE Q Plus B Eco-aura controls ready -
TP653B/LH (left hand config) or
TP653B/RH (right hand config) - Energy Rating A+
TP653BC (Cold Climate) - Energy Rating A+
 Fitted with drop down filter flap panel

Filters:

XP2010561 - ISO Coarse 65% (G4) bypass filter set fitted as standard.

XP2010929 - ISO Coarse 65% (G4)/ISO ePM1 75% (F7) available on request.

Standards

Conforms to requirements of UK statutory Building Regulations and Technical Standards for Ventilation and BRE 398

SAP Appendix Q tested

Exceeds requirements of Building Regulations Approved Document L (England & Wales)

EU RoHS Directive compliant.

Conforms to requirements of EC council directives relating to Electromagnetic Compatibility and Electrical Safety:
 2006/95/EC (LVD), 2004/108/EC (EMC) EN 60335-1:2002/A2:2006, EN 60335-2-80:2003/A1:2004.

CE and UKCA marked.

Specification

Dimensions: HRV20 HE Q Plus - 752mm wide x 708mm high (excluding ports) x 533mm deep (549mm with mounting bracket).

Weight: 46kg.

Finish: White Paint.

Materials:

Housing: Zintec sheet steel housing, powder coated white

Internals: Expanded polypropylene (EPP)

Heat exchanger: Polystyrene

Internal insulation: Closed cell foamed Nitrile rubber, class 'O' fire rating

Standard filters: ISO Coarse 65% (G4).

Guarantee period: 3 years (UK only).

Electrical: 230V ~ 50/60Hz, 5A fuse.

Installation: To be installed accordance with the relevant and applicable building regulations.

Maintenance: Service and filter clean/replacement subject to local environment - see product manual.

Acoustics: Full acoustic data available online www.titon.com/acoustics.

Drawing & Dimensions

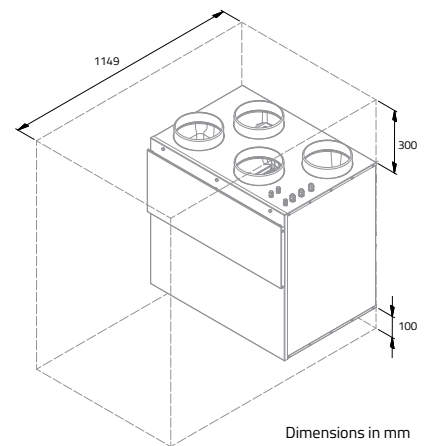
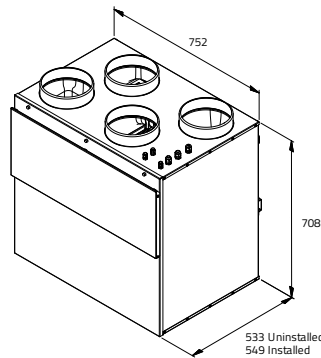

Dimensions in mm

Performance

The figures and compliance levels below relate to current SAP requirements. Revised SAP guidance will have an effect on performance and up-to-date figures can be found on the relevant product page at www.titon.com.

Exhaust terminal configuration*	Fan speed setting	2009		2012	
		SFP (W/l/s)	Heat exchange efficiency (%)	SFP (W/l/s)	Heat exchange efficiency (%)
Kitchen + 1 additional wet room	100% variable	0.52	92%	0.52	91%
Kitchen + 2 additional wet rooms	100% variable	0.48	91%	0.53	91%
Kitchen + 3 additional wet rooms	100% variable	0.48	91%	0.58	90%
Kitchen + 4 additional wet rooms	100% variable	0.53	90%	0.68	90%
Kitchen + 5 additional wet rooms	100% variable	0.58	90%	0.79	89%
Kitchen + 6 additional wet rooms	100% variable	0.66	90%	0.95	89%
Kitchen + 7 additional wet rooms	100% variable	0.76	89%	1.15	88%

Figures taken from the BRE Test Results.

*Number of wet rooms is based on SAP Q test criteria and does not correlate directly with regulatory performance requirements.

Nominal Fan Performance

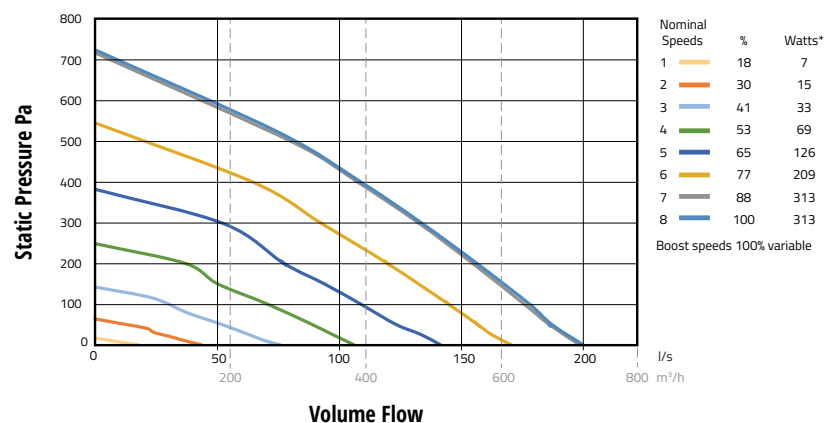

*@FID (0 Pa)

100% variable speed control. Performance curves for Eco version.

Acoustic Data

Product	% of Max flow	Airflow	dB(A) @ 3m Hemispherical			dB(A) @ 3m Spherical
			Induct Inlet	Induct Outlet	Casing Breakout	Casing Breakout
HRV20 HE Q Plus	41%	65l/s @ 18Pa	33	43	27	24
	65%	116l/s @ 51Pa	46	58	42	39
	100%	170l/s @ 100Pa	57	70	49	46

For full frequency acoustic data at various speeds please see www.titon.com. All acoustic data is third party tested at Sound Research Laboratories (SRL) Ltd.

HRV20 HE Q Plus - Enthalpy

Ultra energy efficient Heat Recovery Ventilation unit

For use in large dwellings

The HRV20 HE Q Plus continuously running whole-house ventilation unit with heat recovery has been specifically designed to give improved performance over older models, in line with new build design requirements.

Combining extremely low power consumption and a highly efficient heat exchanger it can be incorporated into larger apartments or dwellings.

The counter flow enthalpy heat exchanger has a selective polymer membrane film to achieve low air leakage levels while providing moisture recovery from the exhaust air. These models are ideal for living areas with low humidity, avoiding frost build up at low temperatures, they also have an antimicrobial membrane and long life cycle.

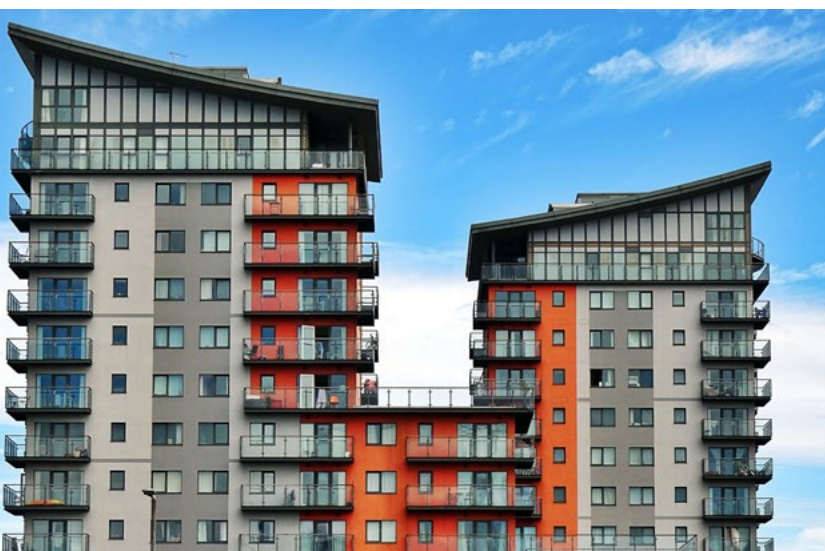
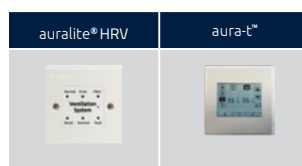
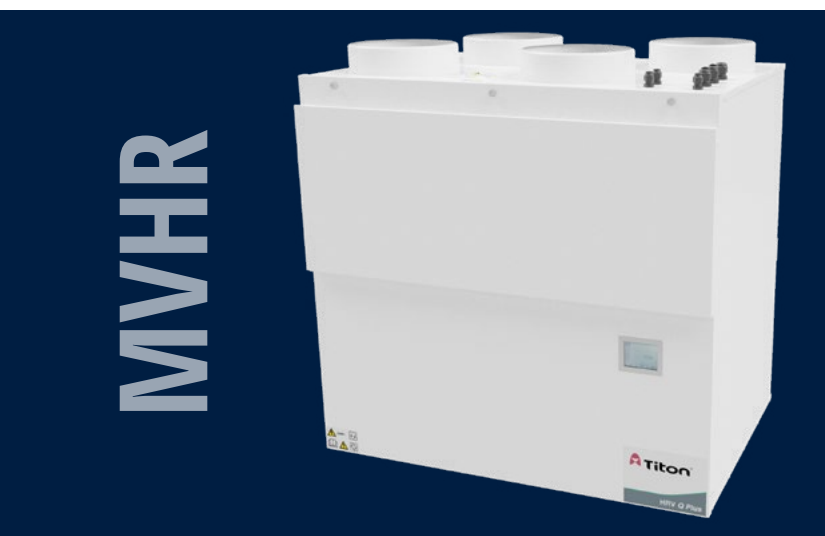

Features & Benefits

- Versatile compact unit
- Highly efficient enthalpy counter flow heat exchanger
- Airflow up to 183l/s (657 m³/h) at 100 Pa
- Accepts 200mm diameter ducting
- Intelligent frost protection, stepped reduction of supply air rates prevents HRV unit from freezing
- ISO Coarse 65% (G4) bypass filter set fitted as standard. ISO Coarse 65% (G4)/ISO ePM1 75% (F7) available on request.
- Fully adjustable boost overrun timer 0-60 minutes; can be used with non-latching (momentary) switch to prevent unit from being accidentally left in boost mode
- Volt free switching control
- Intelligent controller, quick and easy to commission
- aura-t™ fitted on board as standard for HMB models and optional for B models
- Quick fix mounting bracket
- Patented
- IP33 rating
- Independent fan adjustment
- Effective in reducing pollutants in the home and improving Indoor Air Quality (IAQ), therefore reducing the risk of Toxic Home Syndrome
- Available in left and right handed configurations
- Intelligent Summer Bypass & humidity controls
- SUMMERboost® facility
- Compatible with Eco-aura range; aurastat®, auramode® and aura-t™ controllers and auralite® HRV (TP519) status indicator
- Duct heater control (requires independent power supply)
- BMS compatible via RS485 (subject to limitations, additional software requirements and specification with any order)
- Low voltage switching (x 3) and live switch (x 2)
- 4 x 0-10v proportional inputs for local demand control room sensors

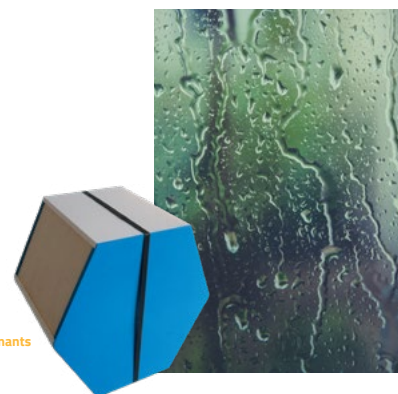
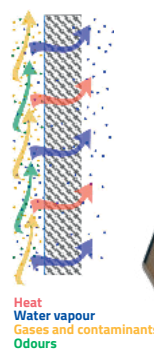

Product Codes

HRV20 HE Q Plus B Eco Enthalpy
Eco-aura controls ready -
TP653BE - Energy Rating A

Filters:

XP2010561 - ISO Coarse 65% (G4) bypass filter set fitted as standard.

XP2010929 - ISO Coarse 65% (G4)/ISO ePM1 75% (F7) available on request.

Standards

EU RoHS Directive compliant.

Conforms to requirements of EC council directives relating to Electromagnetic Compatibility and Electrical Safety:

2006/95/EC (LVD), 2004/108/EC (EMC)

EN 60335-1:2002/A2:2006, EN 60335-2- 80:2003/A1:2004.

CE and UKCA marked.

Specification

Dimensions: 752mm wide x 708mm high (excluding ports) x 533mm deep (549mm with mounting bracket).

Weight: 51kg.

Finish: White Paint.

Materials:

Housing: Zintec sheet steel housing, powder coated white.

Internals: Expanded polypropylene (EPP).

Heat exchanger: Polystyrene.

Internal insulation: Closed cell foamed Nitrile rubber, class 'O' fire rating.

Guarantee period: 3 years (UK only)

Electrical: 230V ~ 50/60Hz, 5A fuse

Installation: To be installed accordance with the relevant and applicable building regulations.

Acoustics: Full acoustic data available online www.titon.com/acoustics.

Drawing & Dimensions

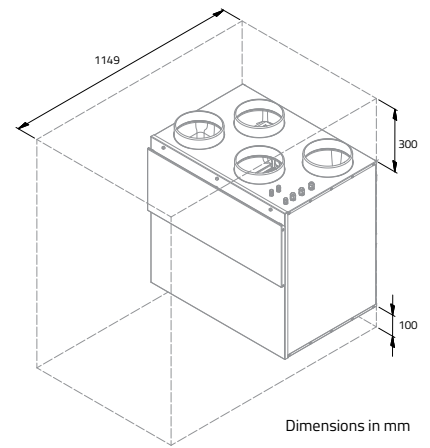
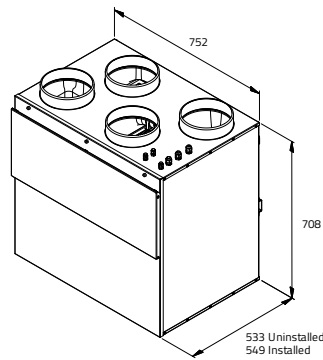

Dimensions in mm

Heat Cell

Technical Data

(Typical conditions at 140 m³/h)

- Heat change rate 80%
- Degree of moisture change 70%
- Leakage at 100 Pa < 1%
- Temperature stability - 25°C up to 65°C

Features & Benefits

- No transfer of gases or pollutants - only heat and water vapour transferred by the membrane
- Long life cycle - permanent transmission parameters
- Minimum leakage
- Optimum flow behaviour, low pressure loss
- Frost- and heat-proof
- High, sensitive and latent transmission rate
- Antimicrobial (Microban® - integrated hygiene protection)
- Can be cleaned using water
- European manufactured heat cell

Nominal Fan Performance

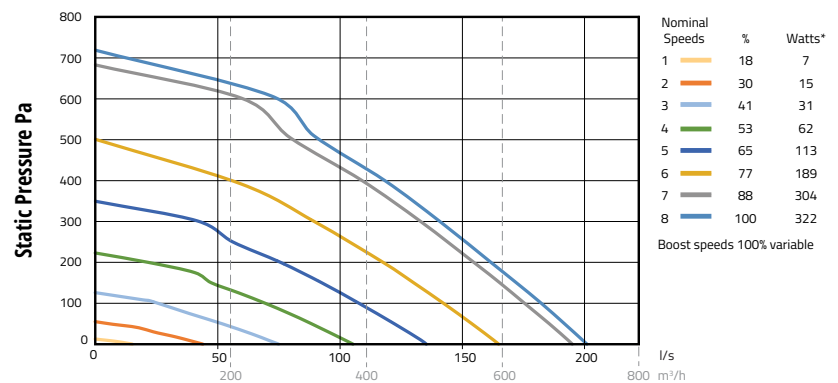

*@FID (0 Pa)
100% variable speed control. Performance curves for Eco version.

Acoustic Data

Product	% of Max flow	Airflow	dB(A) @ 3m Hemispherical			dB(A) @ 3m Spherical
			Induct Inlet	Induct Outlet	Casing Breakout	Casing Breakout
HRV20 Q Plus Enthalpy	41%	65l/s @ 18Pa	33	43	27	24
	65%	123l/s @ 51Pa	46	58	42	39
	100%	183l/s @ 100Pa	57	70	49	46

For full frequency acoustic data at various speeds please see www.titon.com. All acoustic data is third party tested at Sound Research Laboratories (SRL) Ltd.

H200 Q Plus

Ultra energy efficient Heat Recovery Ventilation unit

For use in a wide range of dwellings

The H200 Q Plus continuously running horizontal whole-house ventilation unit with heat recovery is independently tested by the BRE. It is ideal for flats due to its low profile.

Combining low power consumption and a highly efficient heat exchanger, this unit enhances SAP performance via Appendix Q and remains versatile enough in size to be equally functional in large through to small apartments alike.

Recognised and listed in the UK Product Characteristics Database and includes intelligent humidity options through controller options.

MVHR

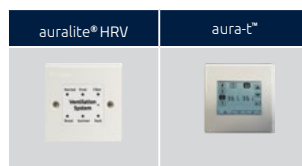

Features & Benefits

- Low profile
- Extremely low SFP; down to 0.55 W/l/s
- Highly efficient heat exchanger; up to 83%
- Airflow up to 83l/s (300 m³/h) at 100 Pa
- Intelligent controller, quick and easy to commission
- Fully adjustable boost overrun timer 0-60 minutes; use with non-latching (momentary) switches to prevent unit from being accidentally left in boost mode
- Accepts either 204mm x 60mm rectangular ducting, 150mm or 160mm diameter ducting, no adaptors required
- Intelligent frost protection, stepped reduction of supply air rates prevents HRV unit from freezing
- Setback facility to reduce ventilation where local regulations allow
- Volt free switching control
- ISO Coarse 65% (G4) filters as standard, ISO ePM1 55% (F7) as an option
- Pleated cardboard frame filters
- IP33 rating
- Independent fan adjustment
- Effective in reducing pollutants in the home and improving Indoor Air Quality (IAQ), therefore reducing the risk of Toxic Home Syndrome
- Intelligent Summer Bypass & humidity controls
- SUMMERboost® facility

Eco HMB Models:

- Compatible with auralite® HRV (TP518) status indicator and aura-t™ controller

Eco B Models:

- Compatible with Eco-aura range; aurastat®, auramode® and aura-t™ controllers and auralite® HRV (TP519) status indicator
- Duct Pre-heater control (requires independent power supply)
- BMS compatible via RS485 (subject to limitations, additional software requirements and specification with any order)
- Low voltage switching (x 3) and live switch (x 2)
- 4 x 0-10v proportional inputs for local demand control room sensors



Product Codes

H200 Q Plus HMB Eco auralite® & aura-t™ ready 204x60
- **TP451HMB** - Energy Rating A

H200 Q Plus HMB Eco auralite® & aura-t™ ready Ø160 -
TP453HMB - Energy Rating A

H200 Q Plus HMB Eco auralite® & aura-t™ ready Ø150 -
TP452HMB - Energy Rating A

H200 Q Plus B Eco-aura controls ready
204x60 - **TP461B** - Energy Rating A
204x60 - **TP461BC** (Cold Climate) - Energy Rating A

H200 Q Plus B Eco-aura controls ready
Ø160 - **TP463B** - Energy Rating A
Ø160 - **TP463BC** (Cold Climate) - Energy Rating A

H200 Q Plus B Eco-aura controls ready
Ø150 - **TP462B** - Energy Rating A
Ø150 - **TP462BC** (Cold Climate) - Energy Rating A

Filters:

XP2010173 - ISO Coarse 85% (G4) filter set fitted as standard.

XP2010174 - ISO ePM1 55% (F7) and ISO Coarse 85% (G4) filters available on request.

Standards

Conforms to requirements of UK statutory Building Regulations and Technical Standards for Ventilation and BRE 398.

SAP Appendix Q tested.

Exceeds requirements of Building Regulations Approved Document L (England & Wales).

EU RoHS Directive compliant.

Conforms to requirements of EC council directives relating to Electromagnetic Compatibility and Electrical Safety:

2006/95/EC (LVD), 2004/108/EC (EMC)

EN 60335-1:2002/A2:2006, EN 60335-2- 80:2003/A1:2004.

CE and UKCA marked.

Specification

Dimensions: 1004mm wide (excluding ports) x 203mm high x 604mm deep

Weight: 32kg

Finish: White Paint

Materials:

Housing: Zintec sheet steel housing, powder coated white

Internal insulation: Closed cell foamed Nitrile rubber, class '0' fire rating

Heat exchanger: aluminium

Standard filters: Grade ISO Coarse 85% (G4) pleated panel filters

Guarantee period: 3 years (UK only)

Electrical: 230V ~ 50/60Hz, 3A fuse

Installation: To be installed accordance with the relevant and applicable building regulations.

Maintenance: Service and filter clean/replacement subject to local environment – see product manual.

Acoustics: Full acoustic data available online www.titon.com/acoustics.

Drawing & Dimensions

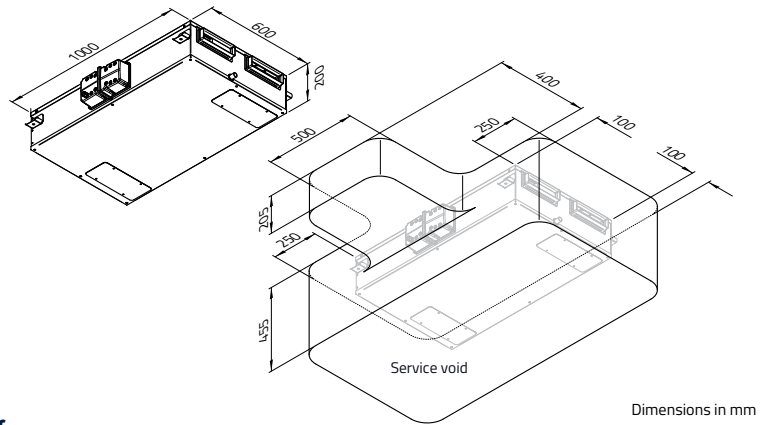

Dimensions in mm

Performance

The figures and compliance levels below relate to current SAP requirements. Revised SAP guidance will have an effect on performance and up-to-date figures can be found on the relevant product page at www.titon.com.

Exhaust terminal configuration*	Fan speed setting	2009		2012	
		SFP (W/l/s)	Heat exchange efficiency (%)	SFP (W/l/s)	Heat exchange efficiency (%)
Kitchen + 1 additional wet room	100% variable	0.58	83%	0.58	83%
Kitchen + 2 additional wet rooms	100% variable	0.55	83%	0.66	82%
Kitchen + 3 additional wet rooms	100% variable	0.61	82%	0.8	80%
Kitchen + 4 additional wet rooms	100% variable	0.72	81%	1.01	80%
Kitchen + 5 additional wet rooms	100% variable	0.85	80%	1.25	80%
Kitchen + 6 additional wet rooms	100% variable	0.99	80%	1.58	82%
Kitchen + 7 additional wet rooms	100% variable	1.2	80%	-	-

Figures taken from the BRE Test Results.

*Number of wet rooms is based on SAP Q test criteria and does not correlate directly with regulatory performance requirements.

Nominal Fan Performance

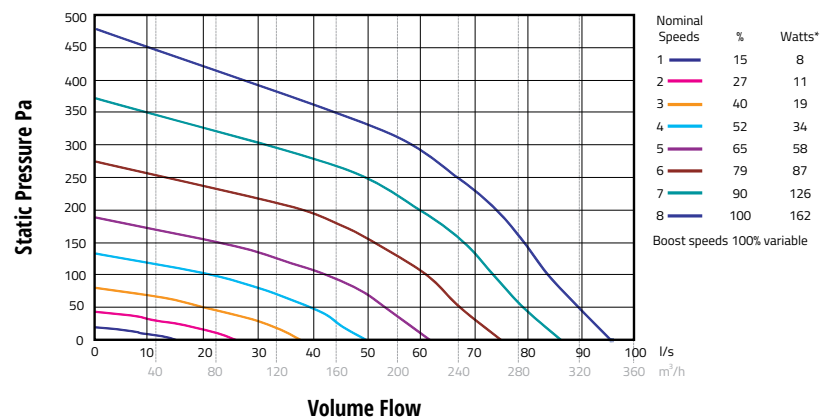

*@FID (0 Pa)

100% variable speed control. Performance curves for Eco version.

Acoustic Data

Product	% of Max flow	Airflow	dB(A) @ 3m Hemispherical			dB(A) @ 3m Spherical
			Induct Inlet	Induct Outlet	Casing Breakout	Casing Breakout
H200 Q Plus	47%	39l/s @ 20Pa	25	37	25	22
	64%	53l/s @ 37Pa	30	21	31	28
	100%	83l/s @ 100Pa	39	54	41	38

For full frequency acoustic data at various speeds please see www.titon.com. All acoustic data is third party tested at Sound Research Laboratories (SRL) Ltd.

HRV Cool Plus™

HRV Accessories

Offering extra protection against overheating

The new Titon HRV Cool Plus™ offers a solution designed to deliver cooling, filtered, and tempered air for user comfort in warmer weather conditions. It seamlessly integrates into heat recovery ventilation systems and has intuitive controls.

Equipped with an integrated cooling module, the HRV Q Plus/MVHR system enhances its performance by pre-cooling incoming fresh air during warmer months. By merging improved air quality and energy efficiency, MVHR systems with cooling modules greatly aid in creating sustainable and comfortable indoor environments, while also aligning with Approved Document O (ADO) guidelines by recycling energy within a home.

Cooling



Features & Benefits

- Up to 3.3 kW total cooling (subject to volume flow and relative humidity)
- Available for wall mounting or floor mounting. When using the wall bracket the supporting wall must be suitable for the combined weight of the cooler, MVHR, bracket assembly. (100 kg Wall / 106 kg Floor)
- No need for run around ducting. Keeps complexity low.
- Minimal maintenance of fully sealed refrigerant heat pump with coil & fin heat exchangers. Similar to a fridge or freezer. Proven & reliable. Refrigerant is R407c (GWP 1774)
- Heat cell will provide cooling assistance to pre-chill incoming fresh air when in operation exactly as it does normally with heat
- Installation below the ceiling in the heated space but compact enough to permit the location of a washing machine below
- Port sizes are 160mm

Operation Cycle

- Pre-set temperature inside the dwelling is reached
- MVHR increased speed to cooler boost
- Once achieved the cooler will start
- Pre-set tempered internal temperature reached
- Cooler will deactivate
- MVHR decreased to continuous levels

Additional Controls

- Optional manual mode via the onboard aura-t™
- Minimum atmosphere temperature controls to ensure the cooler doesn't operate with the dwelling heating system
- Cooler can be deactivated via the thermostat and/or onboard aura-t™

How

- Thermostat in Cooling Mode
- MVHR atmospheric temperature sensing
- Sufficient airflow for cooling operation automatically set by our controls
- Internal pressure sensors ensure cooler operates only when sufficient airflow is maintained
- Active communication between MVHR and Cooler

Mechanical Ventilation with Heat Recovery (MVHR) is a critical system in modern building design, serving as a key component for maintaining indoor air quality and energy efficiency. MVHR systems are primarily designed to provide a constant supply of fresh, filtered air while simultaneously expelling stale air from within a building. This process not only ensures a healthier indoor environment by reducing pollutants and excess humidity but also plays a vital role in conserving energy.

Product Codes

HRV Cool Q Plus™ -
 TP755 - Wall mounted unit
 TP754 - Floor mounted unit
 (left hand config only)

Filters:
 ISO Coarse 85% (G4) filters fitted as standard.

Pack requirements

- Cooler enabled HRV Q Plus MVHR
- HRV Cool Plus™ cooler
- Connection silencer ducts x 4
- Room Thermostat
- Wall mounting bracket or Floor standing bracket
- Middle duct cover

Accessories

- Cooler top duct cover
- HRV Drain Cover

Please note that the room thermostat will be in the packing for the HRV MVHR and that the 'Duct cover' will be part of the mounting kits.

Standards

Conforms to requirements of UK statutory Building Regulations and Technical Standards for Ventilation.

Meets requirements of Building Regulations Approved Document O (England & Wales).

EU RoHS Directive compliant.

Conforms to requirements of EC council directives relating to Electromagnetic Compatibility and Electrical Safety:
 2006/95/EC (LVD), 2004/108/EC (EMC)
 EN 60335-1:2002/A2:2006, EN 60335-2- 80:2003/A1:2004.
 CE and UKCA marked.

Specification

Dimensions:

Wall mounted
 704mm wide x 515mm deep x 1430 high (excluding ports).
 Floor mounted
 704mm wide x 515mm deep x 2005 high (excluding ports).

Weight: Wall mounted 100kg, Floor mounted 106kg
Finish: White Paint (RAL9016 Semi-gloss Traffic White)

Materials:

Housing: Zintec sheet steel housing, powder coated white
 Internals: Expanded polypropylene (EPP)
 Heat exchanger: Made from high quality PET materials
 Internal insulation: Closed cell foamed Nitrile rubber, class 'O' fire rating
 Standard filters: Grade ISO Coarse 85% (G4) synthetic filters.

Electrical:

HRV Unit: 230V ~ 50/60Hz, 5A fuse
 Cooler: 230V ~ 50/60Hz, 8A fuse

Installation: To be installed accordance with the relevant and applicable building regulations.

Maintenance: Service and filter clean/replacement subject to local environment - see product manual.

Acoustics: Full acoustic data available online
www.titon.com/acoustics.

Nominal Fan Performance

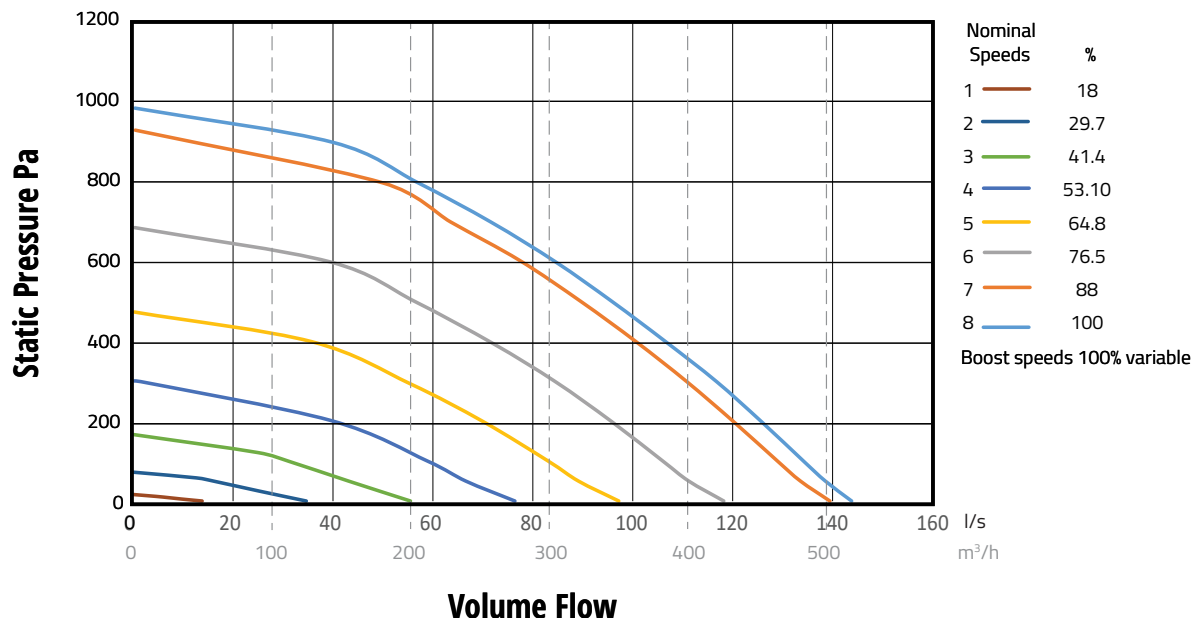

Acoustic Data

Product	% of Max flow	Airflow	dB(A) @ 3m Hemispherical			dB(A) @ 3m Spherical
			Induct Inlet	Induct Outlet	Casing Breakout	Casing Breakout
HRV Cool Q Plus™	57%	76l/s @ 35Pa	33	37	35	32
	76%	100l/s @ 71Pa	41	44	46	43
	100%	134l/s @ 100Pa	48	48	50	47

For full frequency acoustic data at various speeds please see www.titon.com. All acoustic data is third party tested at Sound Research Laboratories (SRL) Ltd.

Wall Mounted - Drawing & Dimensions

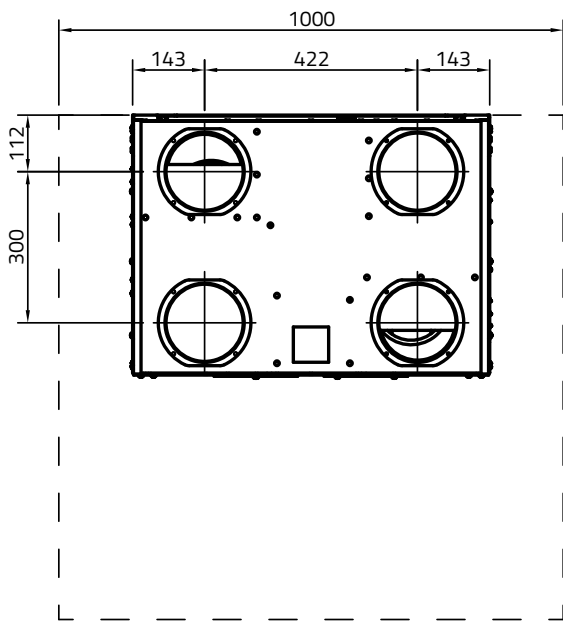

Ports $\varnothing 160$

100 kg

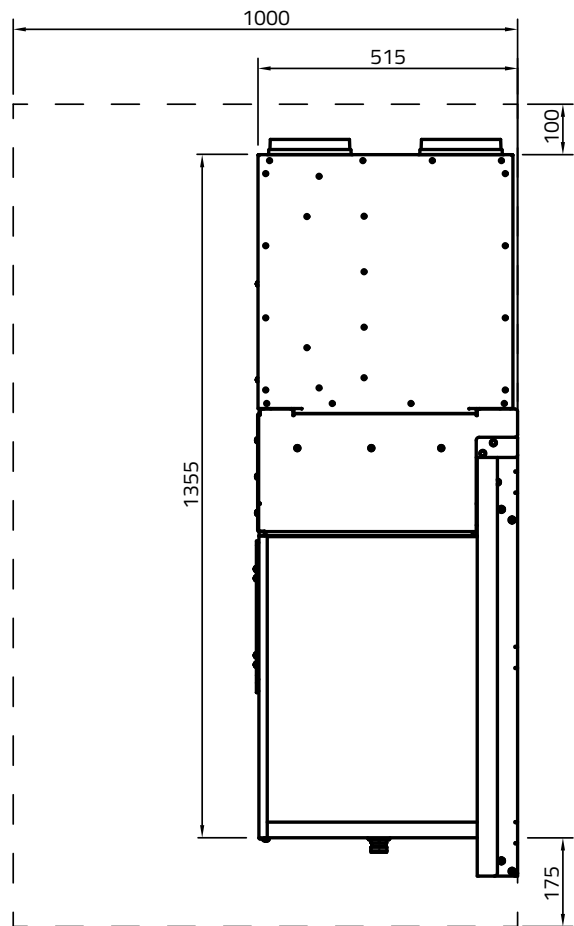
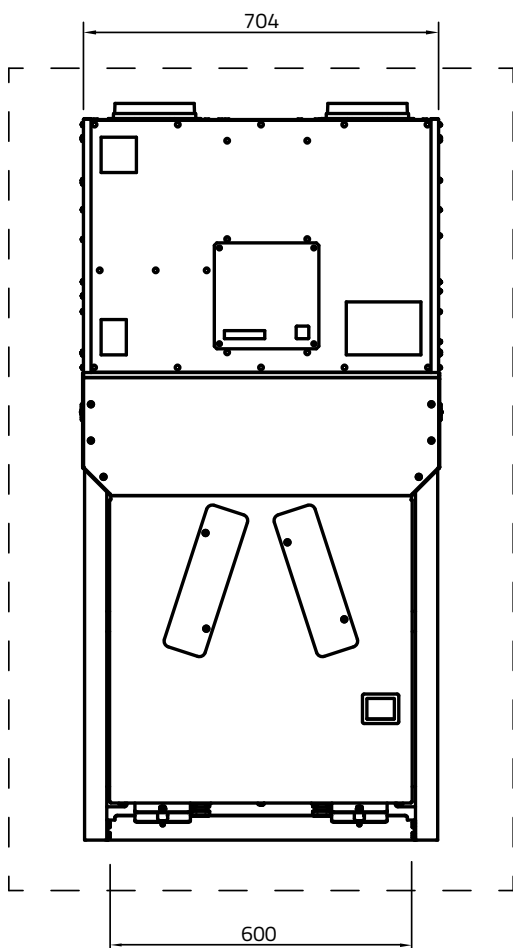

Dimensions in mm

Floor Mounted - Drawing & Dimensions

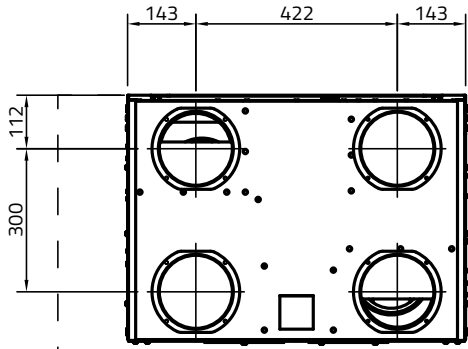

Ports Ø160

106 kg

..... 300 Void is required to enable fitment of optional duct cover

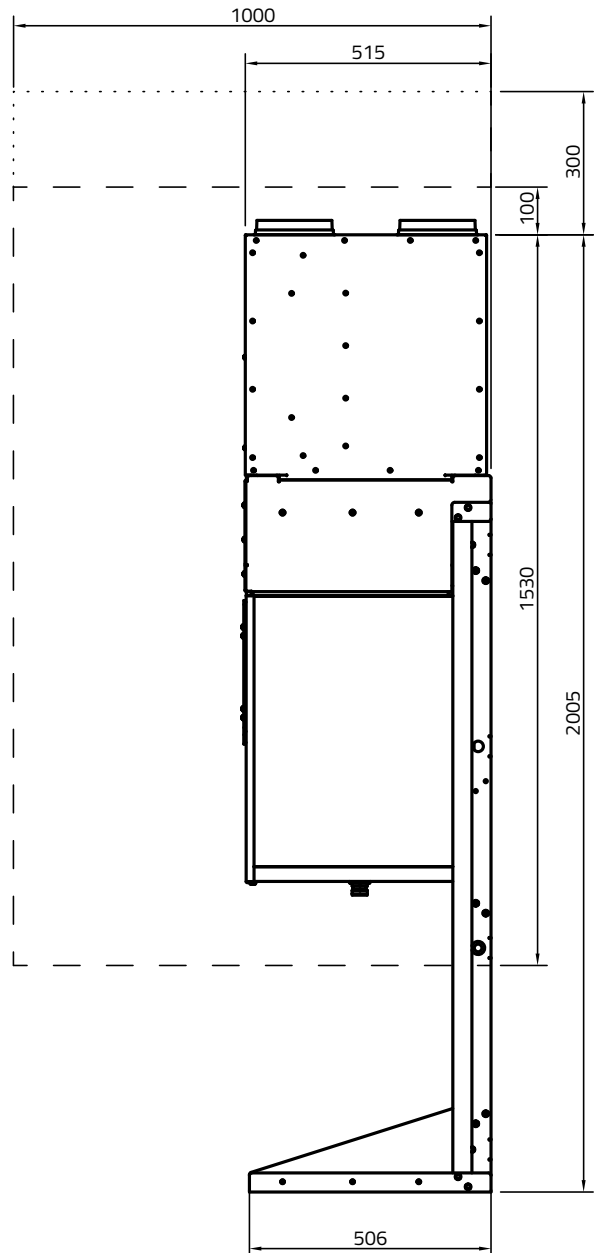
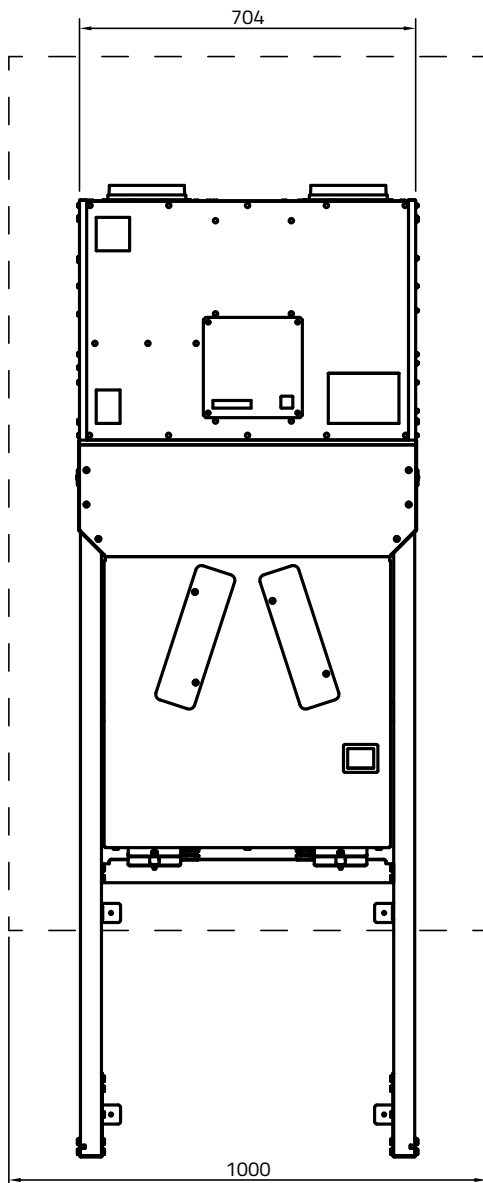

Dimensions in mm

Preliminary Tempering Performance

db 29 wb 21.2 - External Air Temperature

Conditions	Cooling (kW) / Airflow Rates (l/s)	60	70	80	90	100	110	120
23°C Internal	Combined Total kW	1.8	1.9	2.1	2.3	2.4	2.6	2.7
	Combined Sensible kW	1.3	1.4	1.6	1.7	1.9	2.0	2.1
	Supply Air °C	11.6	12.2	12.7	13.1	13.5	13.9	14.2
24°C Internal	Combined Total kW	1.7	1.9	2.0	2.2	2.3	2.5	2.6
	Combined Sensible kW	1.2	1.4	1.5	1.7	1.8	2.0	2.1
	Supply Air °C	12.0	12.5	13.0	13.4	13.8	14.2	14.5
25°C Internal	Combined Total kW	1.6	1.8	2.0	2.1	2.2	2.4	2.5
	Combined Sensible kW	1.2	1.4	1.5	1.7	1.8	1.9	2.1
	Supply Air °C	12.3	12.9	13.4	13.8	14.2	14.5	14.8
26°C Internal	Combined Total kW	1.6	1.7	1.9	2.0	2.1	2.3	2.4
	Combined Sensible kW	1.2	1.3	1.5	1.6	1.7	1.9	2.0
	Supply Air °C	12.7	13.2	13.7	14.1	14.5	14.8	15.1

db 32 wb 23.7 - External Air Temperature

Conditions	Cooling (kW) / Airflow Rates (l/s)	60	70	80	90	100	110	120
23°C Internal	Combined Total kW	1.9	2.2	2.4	2.6	2.7	2.9	3.1
	Combined Sensible kW	1.3	1.5	1.7	1.8	2.0	2.1	2.3
	Supply Air °C	14.0	14.4	14.9	15.3	15.6	15.9	16.2
24°C Internal	Combined Total kW	1.9	2.1	2.3	2.5	2.6	2.8	3.0
	Combined Sensible kW	1.3	1.5	1.6	1.8	1.9	2.1	2.2
	Supply Air °C	14.3	14.8	15.2	15.6	15.9	16.2	16.5
25°C Internal	Combined Total kW	1.8	2.0	2.2	2.4	2.5	2.7	2.8
	Combined Sensible kW	1.3	1.4	1.6	1.7	1.9	2.0	2.2
	Supply Air °C	14.6	15.1	15.5	15.9	16.2	16.5	16.8
26°C Internal	Combined Total kW	1.8	2.0	2.1	2.3	2.5	2.6	2.7
	Combined Sensible kW	1.2	1.4	1.6	1.7	1.9	2.0	2.2
	Supply Air °C	15.0	15.4	15.8	16.2	16.5	16.8	17.1

db 34 wb 25.3 - External Air Temperature

Conditions	Cooling (kW) / Airflow Rates (l/s)	60	70	80	90	100	110	120
23°C Internal	Combined Total kW	2.0	2.3	2.5	2.7	2.9	3.1	3.3
	Combined Sensible kW	1.3	1.5	1.7	1.9	2.0	2.2	2.4
	Supply Air °C	15.5	16.0	16.4	16.7	17.1	17.4	17.6
24°C Internal	Combined Total kW	2.0	2.2	2.4	2.7	2.8	3.0	3.2
	Combined Sensible kW	1.3	1.5	1.7	1.8	2.0	2.2	2.3
	Supply Air °C	15.9	16.3	16.7	17.0	17.4	17.6	17.9
25°C Internal	Combined Total kW	1.9	2.2	2.4	2.6	2.8	2.9	3.1
	Combined Sensible kW	1.3	1.5	1.6	1.8	2.0	2.1	2.3
	Supply Air °C	16.2	16.6	17.0	17.3	17.6	17.9	18.2
26°C Internal	Combined Total kW	1.9	2.1	2.3	2.5	2.7	2.8	3.0
	Combined Sensible kW	1.3	1.4	1.6	1.8	1.9	2.1	2.2
	Supply Air °C	16.6	16.9	17.3	17.6	17.9	18.2	18.5

The combined total kW cooling accounted for coolth recovery, sensible and latent cooling. These results therefore reflect expected cooling power and supply air temperatures when in operation. For cooling output data based on your assumed external design conditions, please consult Titon.

Introducing the new

HRV COOL PLUS™



The **smart choice** for thermal comfort **all year round**

Overheating indoors can present several dangers, such as heat-related stress, dehydration, and heightened health issues. The new Titon HRV Cool Plus™ offers a solution designed to deliver cooling, filtered air for user comfort in warmer weather conditions via a compact efficient MVHR and cooling module.

- Up to 3.3kW total cooling (subject to volume flow and relative humidity)
- Available for wall mounting or floor mounting.
- No need for run around ducting. Keeps complexity low.
- Minimal maintenance of fully sealed refrigerant heat pump with coil & fin heat exchangers.
- Heat cell will provide cooling assistance to pre-chill incoming fresh air when in operation exactly as it does normally with heat
- CIBSE accredited CPD course available on Part O



01206 713801 | marketing@titon.co.uk | titon.com

 **Titon**[®]
ventilation systems

SR700

Single Room Heat Recovery Unit

For use in residential dwellings

The SR700 from Titon is a decentralised ventilation unit with heat recovery providing continuous airflow to your home. It extracts stale, moist and contaminated air and replaces it with warmed fresh air from outside, improving indoor air quality and keeping heating costs down.

The system is easily installed and maintained, ideal for removing internal condensation and eliminating mould growth within the home. Unlike regular extractor fans that waste 100% of heat that passes through them, the SR700 system will recover up to 84%* of wasted heat and create a comfortable living environment. It is recommended that the system is designed in pairs to allow for the system to work to its full capability.

Features & Benefits

- Easy to maintain
- Low noise and vibration levels due to expanded polypropylene housing
- Low profile wall mounted fascia
- No additional ductwork required
- 'Sleep mode' function. By putting the unit to sleep, fans can be configured to either stop (default) or slow to humidity protection level for a period of time (default 1 hour) after which they will return to the previous setting
- 'Intensive speed' (Manual) to quickly remove any odours that are present.
- 'Intensive speed' (Automatic) to quickly remove excessive amounts of poor air, moisture and dangerous levels of Carbon Dioxide from within the home. (Sensors required).
- 'Cross ventilation' for a constant flow of fresh air through the house (No heat recovery)
- Wall thickness: Min. 305mm - Max. 700mm+
- Achieves 20Pa back pressure as per BS EN 13141-8:2014
- SR700 controller can connect up to 6 fans

SR700

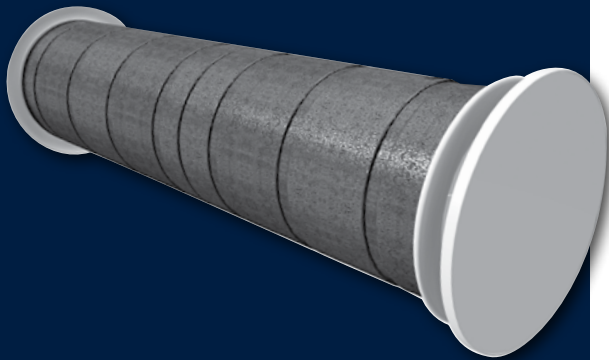

SRC Controller

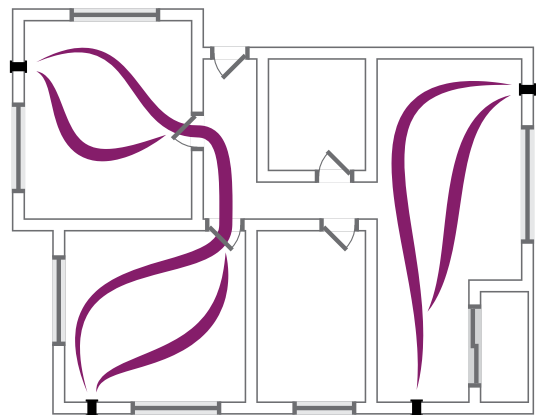

Drawing & Dimensions

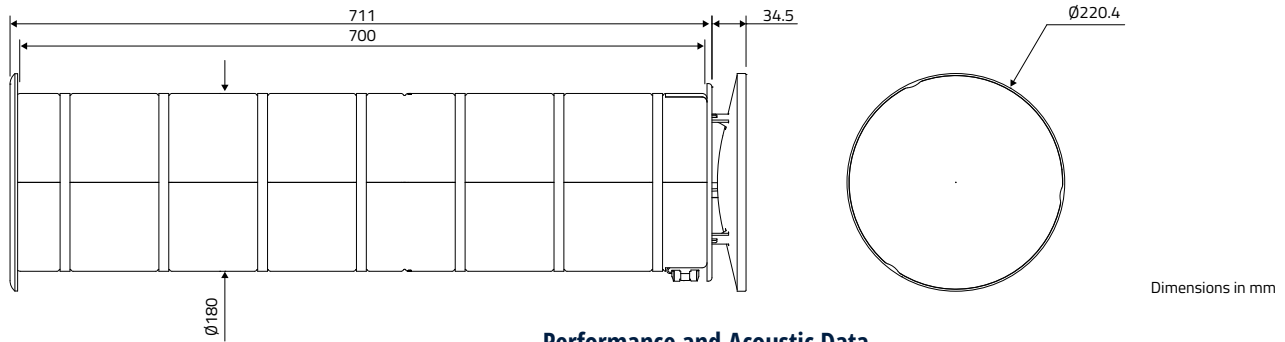

Dimensions in mm

Product Codes

TP600 - SR700

TP590 - SRC1 (Control unit)

XP2010311 - Replacement PM Coarse 55% (G3) filter

XP2010320 - Replacement insect filter

TP614 - Relative humidity (RH) sensor (flush mount)

TP616 - Combined relative humidity (RH) and Carbon dioxide (CO₂) sensor (flush mount)

TP617 - Volatile organic compound (VOC)/Air quality sensor (flush mount) quality sensor (flush mount)

Standards

BS EN 13141-8:2014 (Ventilation for buildings)

EN 55014-1:2006 inc A1:2009 & A2:2011

EN 55014-2:2015 category IV

EN 61000-3-2:2014

EN 61000-3-3:2013 (Electromagnetic compatibility [EMC]) BS

EN ISO 717-1:2013

BS EN ISO 10140-2:2010

BS EN ISO 3741:2010 (Acoustics)

IEC 60335-2-80:2002 +A1:2004, +A2:2008 in conjunction with IEC 60335-1:2010

BS EN 60335-2-80:2003 +A1:2004, +A2:2009 in conjunction with EN 60335-1:2012/AC:2014 +A11:2014

BS EN 62233 (Electrical Safety)

CE and UKCA marked.

Specification

Dimensions: 711 long x Ø180 inside wall & Ø220mm x 35mm internal fascia

Weight: SR700 - 3Kg, SRC1 controller - 94g

Materials:

Tube: Expanded polypropylene (EPP)

Components: White ABS plastic

Heat exchanger: Ceramic

Filters: Synthetic

Internal insulation: Closed cell foamed nitrile

Fascia plate: White Perspex

Guarantee period: 2 years

Electrical: 230V ~ 50/60Hz, 3A fuse

Installation: The Titon SRHRV Fan unit is designed to be mounted through a wall with a thickness between 305mm & 700mm.

Maintenance: Easy to maintain. Routine service and filter clean/ replacement are all that are normally required to keep the SRHRV System working efficiently. Subject to local environment - see product manual.

Performance and Acoustic Data

Product	Fan Speed Setting	Airflow (m ³ /h)	dB(A) Max @ 3m Hemispherical	SFP (W/l/s) @0 pa
SR700	Fan Setting 1 (Large Dwelling)			
	*Sleep Mode	6.5 or off	8/0	0.62
	*Off	-	-	-
	Humidity protection	6.5	8	0.62
	Reduced	20	19	0.27
	Nominal	40	32	0.22
	Intensive	60	39	0.24
	Fan Setting 2 (Small Dwelling)			
	*Sleep Mode	6.5 or off	8/0	0.62
	*Off	-	-	-
	Humidity protection	6.5	8	0.64
	Reduced	10	11	0.44
	Nominal	17	18	0.3
	Intensive	25	24	0.24

*Configurable option

Airborne sound insulation. Rating according to: BS EN ISO 717-1:2013 & BS EN ISO 10140-2:2010	
Status	Dn,e,w (c;ctr)
Unit Open	34dB
Unit Closed	51dB

SRC1 Controller

A system consists of a central control unit which manages between 1 and 3 off pairs of through the wall 12V --- (dc) bidirectional fan units which are typically fitted in pairs so that they can provide cross flow ventilation within the home.

A controlled ventilation system such as the SR700 from Titon meets the criteria for low energy housing and is ideal for installing during refurbishment of a home.



Part Number - **TP590**

Sensors



Flush mount

Sensor Description	Flush Mount
Relative humidity (RH) Sensor	TP614
Combined relative humidity (RH) and Carbon Dioxide (CO ₂) Sensor	TP616
Volatile organic compound (VOC)/Air Quality Sensor	TP617

Trimbox NO₂ Filter[®]

HRV Accessories

Offering extra protection against external NO₂ pollutants

The Titon Trimbox NO₂ Filter[®] reduces Nitrogen Dioxide (NO₂) which is predominately produced by exhaust gases from diesel engines.

Due to this pollution arising in cities and urban areas there is a need to implement mitigation measures to improve the indoor air quality (IAQ). The Trimbox NO₂ Filter[®] is an effective means of reducing high NO₂ to an acceptable mean annual concentration level of 40µg/m³.

In addition to outstanding NO₂ reductions, the Titon Trimbox active carbon filters also absorb sulphur dioxide, hydrogen sulphide, hydrogen chloride, ammonia odours, volatile organic compounds and solvents.



NO₂ Filter

Features & Benefits

- Effective in reducing pollutants in the home, improving Indoor Air Quality (IAQ) and reducing the risk of Toxic Home Syndrome
- Low pressure drop
- Low cost
- Optional ISO ePM1 55% (F7) filter can be installed to further improve indoor air quality
- Independently tested by BRE
- Small compact design
- Compatible with Titon's range of MVHR units
- Fully lined box to reduce duct bound noise and condensation
- The unit can be installed in both intake air and supply ducting
- 98% NO₂ reduction at pre filter concentrations of ≈ 200µg m³
- Effective silencer
- Third party tested for both NO₂ and Acoustic reductions
- ISO Coarse 60% (G4) filter reduces 100% of PM10/35% of PM2.5 particles
- ISO ePM1 55% (F7) filter reduces up to 95% of PM2.5 particles

Nitrogen dioxide filtration and unit pressure drop

(Based on nitrogen dioxide pre filter concentrations of ≈ 200µg m³)

Airflow rate (l/s)	Filter pressure drop (Pa)	Concentration reduction (%)
Unit One (3 filters)		
29	31	97.6
80.3	134	97.9
Unit Two (4 filters)		
45.3	50	98.1
80.6	106	97.5

Behind unit duct mounting kit available

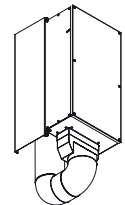

Acoustic Data

Independently tested at SRL, report reference C/23276/T05 to BS EN ISO 7235:2009

Description	Octave Band (Hz) Static Insertion Loss, dB							
	63	125	250	500	1000	2000	4000	8000
Unit One (3 filters)	6.5	7.6	4.9	8.6	16.1	26.8	32.9	36
Unit Two (4 filters)	6.1	6.8	5.6	10	18.5	35.3	35	39.8

All data is third party tested at BRE and Sound Research Laboratories (SRL) Ltd.

Product Codes

Unit One (3 Filters):

TP550 220 x 90, **TP552** Ø160, **TP554** Ø150

Unit Two (4 Filters):

TP551 220 x 90, **TP553** Ø160, **TP555** Ø150

Filters:

XP2010121 - ISO ePM1 55% (F7) pre filter (ISO Coarse 60% (G4) standard in units)

Removable insulation jacket:

XP9910248 - 220x90mm ports

XP9910305 - 150 or 160mm ports

TP558 - Behind unit duct mounting kit

Standards

Third party tested for both NO₂ and acoustic reductions based around the standards currently in place for health as specified by the World Health Organisation and the European Union.

Testing references:

COSHH - Workplace exposure limits

COMEAP - Government guidance regarding health of air pollution

WHO - World Health Organisation

Specification

Dimensions: 350mm wide x 690mm high (excluding ports) x 205mm deep

Port Dimension: 220mm x 90mm, Ø150mm, Ø160mm

Weight:

Unit One (3 Filters) - 17 Kg

Unit Two (4 Filters) - 20 Kg

Insulation Jacket - 2.8 Kg

Finish: White Paint

Materials:

Housing: Zintec sheet steel housing, powder coated white.

Internals: Zintec sheet steel.

Pre-Filter: Grade ISO Coarse 60% (G4) synthetic filters as standard, ISO ePM1 55% (F7) optional.

Active Carbon Filter: Honeycomb matrix constructed filter filled with granular active carbon.

Internal Insulation: Closed cell foamed nitrile rubber, class 'O' fire rating.

Duct Ports: Plastic.

Installation: To be installed accordance with the relevant and applicable building regulations.

These units can be installed either vertically or horizontally.

Maintenance: Service and filter cleaning/replacement subject to local environment – see product manual.

Accessories: Replacement pre-filters and active carbon filters.

Drawing & Dimensions

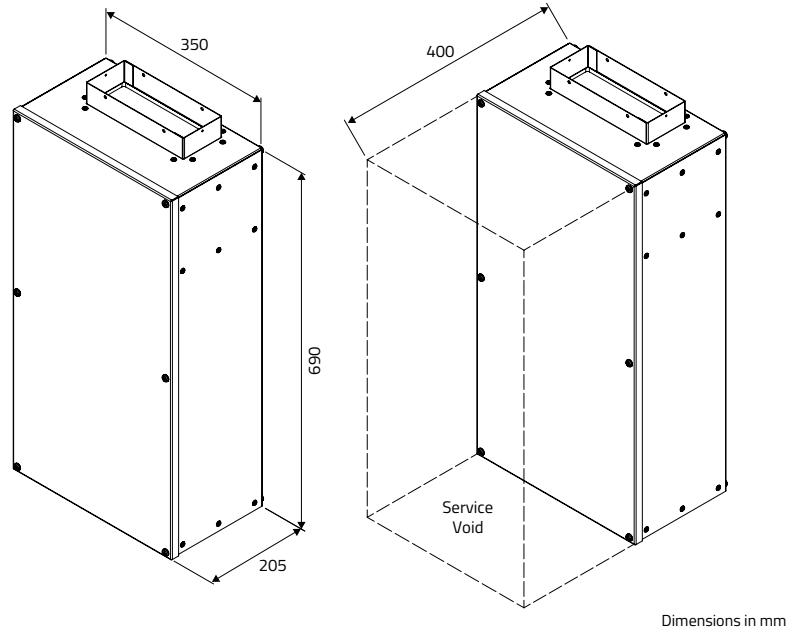

Resistance - Trimbox NO2 Filter*

ISO Coarse 60% (G4) Prefilter

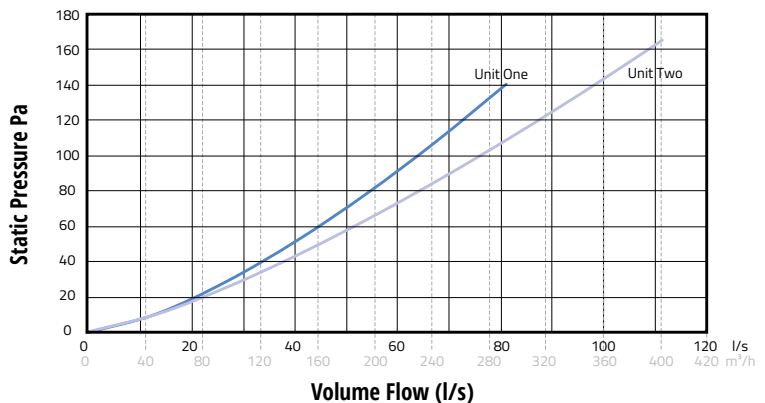

ISO ePM1 55% (F7) Prefilter

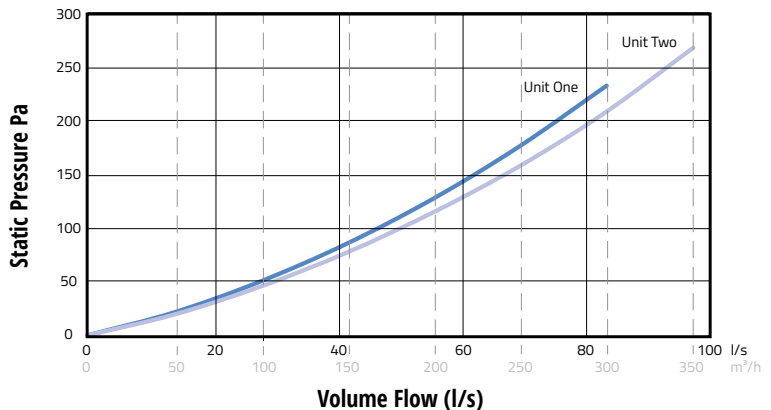

Trimbox Filter®

HRV Accessories

Offering extra protection against external pollutants

Titon's new Trimbox Filter - Lined (insulated) and Unlined Units reduces outdoor air pollutants as part of your building ventilation system.

With pollution an ever increasing problem, the Trimbox Filter® allows for extra protection within the home. By adding a Trimbox Filter® to the ventilation system, it allows increased protection from external contaminants. Ideal for new build or refurbishment, the Trimbox Filter® creates a safer environment for any dwelling.

Features & Benefits

- Low pressure drop
- Low cost
- Both ISO Coarse 60% (G4) and ISO ePM1 55% (F7) pleated filter options
- Compact design
- Compatible with Titon's range of MVHR units
- Fully lined version reduces the risk of duct bound noise and condensation
- The unit can be installed in both intake air and supply ducting
- ISO Coarse 60% (G4) filter reduces 100% of PM10/35% of PM2.5 particles
- ISO ePM1 55% (F7) filter reduces up to 95% of PM2.5 particles

Filter



Lined - Unit
(insulated)



Unlined - Unit
(uninsulated)

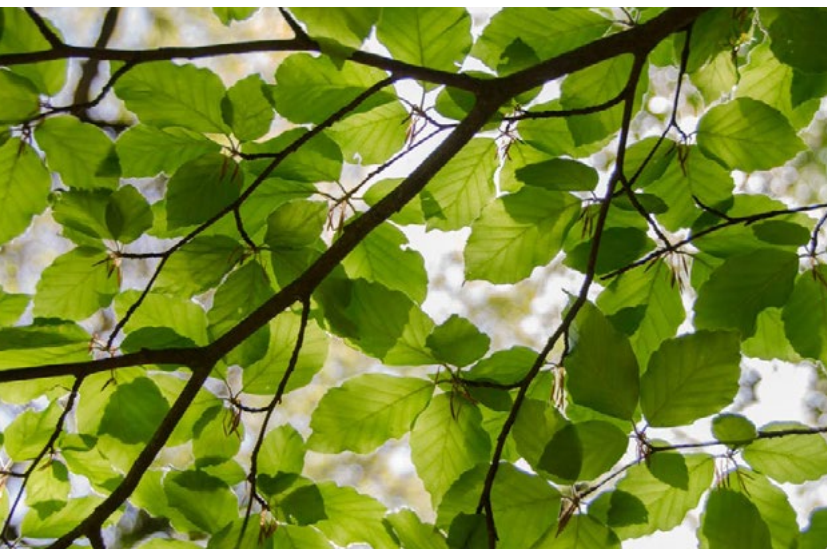

Product Codes

Lined Version

TP560 - 204x60
 TP561 - 220x90
 TP562 - Ø125
 TP563 - Ø150
 TP564 - Ø160

Unlined Version

TP565 - 204 x 60
 TP566 - 220 x 90
 TP567 - Ø125
 TP568 - Ø150
 TP569 - Ø160

Replacement filters:

XP2010021 - ISO Coarse 60% (G4) Filter

XP2010121 - ISO ePM1 55% (F7) Filter

Standards

Conforms to the European standard for air filters (ISO16890 and EN779:2012).

Specification

Lined Version

Dimensions: 355mm wide x 203mm high (excluding ports) x 206mm deep.

Unlined Version

Dimensions: 338mm wide x 208mm high (excluding ports) x 200mm deep.

Lined & Unlined Versions

Port Dimension: 204mm x 60mm, 220mm x 90mm, Ø125mm, Ø150mm, Ø160mm.

Weight: 4 Kg.

Finish: White Paint/Zintec Finish.

Materials:

Housing: Zintec sheet steel housing, powder coated white.

Filters: Grade ISO Coarse 60% (G4) synthetic filters as standard/ISO ePM1 55% (F7) wet-laid glass fibre paper.

Internal insulation: Closed cell foamed nitrile rubber, class 'O' fire rating.

Installation: To be installed accordance with the relevant and applicable building regulations.

These units can be installed both vertically and horizontally.

Maintenance: Service and filter cleaning/replacement subject to local environment – see Product Manual.

Drawing & Dimensions

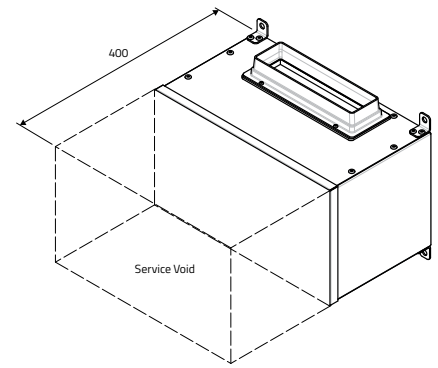
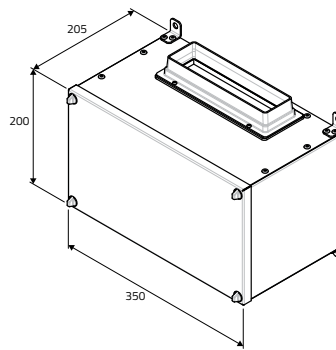

Dimensions in mm

Resistance - Trimbox Filter®

ISO Coarse 60% (G4) filter

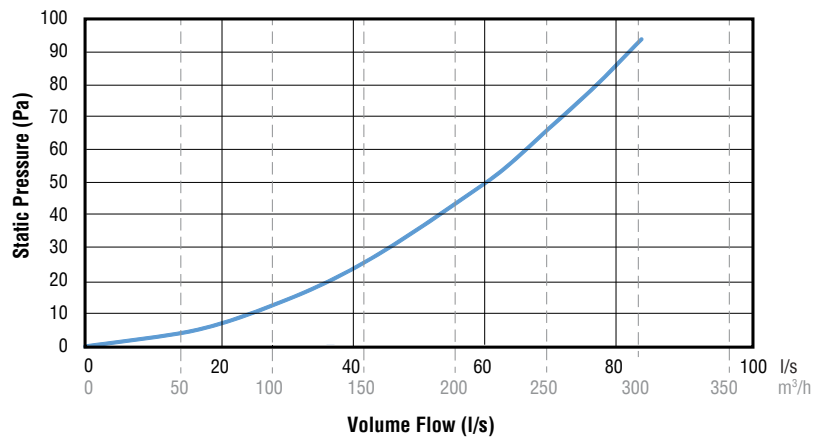

ISO ePM1 55% (F7) filter

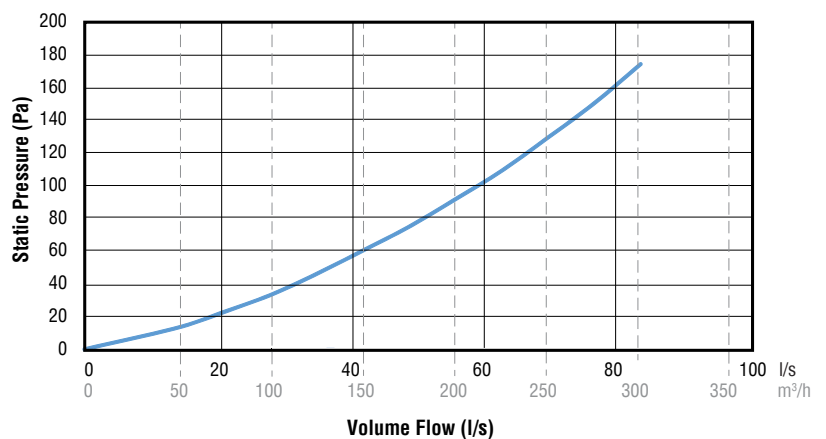

HRV Condensate Drain Cover

HRV Accessories

For use with Titon HRV units

HRV Condensate Drain Covers are designed to conceal the service pipe attached to the underside of Titon HRV units to improve overall appearance.

The covers match the construction, quality and finish of the HRV units and can be easily installed and removed if required.

The cover has a depth of 74mm and the drainage pipe must be installed within this depth for the cover to be fitted. The drainage trap cannot be installed within this cover void, therefore it must be located in a suitable alternative position.

Product Codes

Model	Part Number
HRV1.25, 1.35	TP545
HRV1.6, 1.65	TP544
HRV1.75, 2, 2.85, 3	TP546
HRV4, 4.25	TP705
HRV10M, 10.25M	TP547
HRV20 HE	TP700

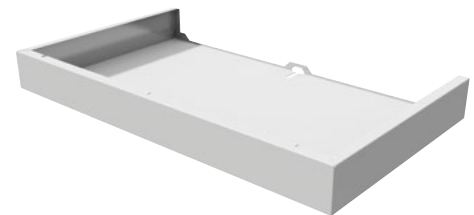
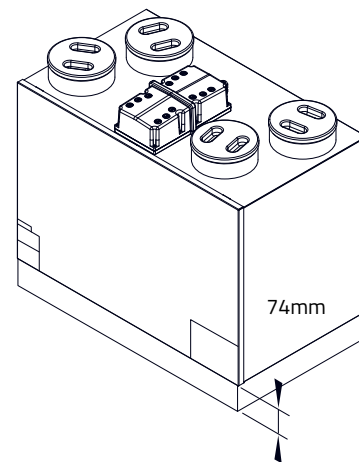

TP544, TP545, TP546, TP705, TP700

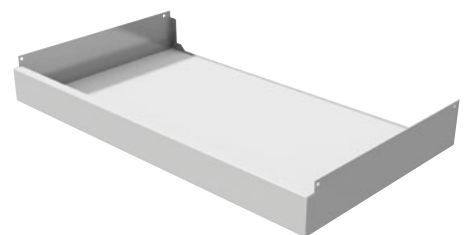

TP547

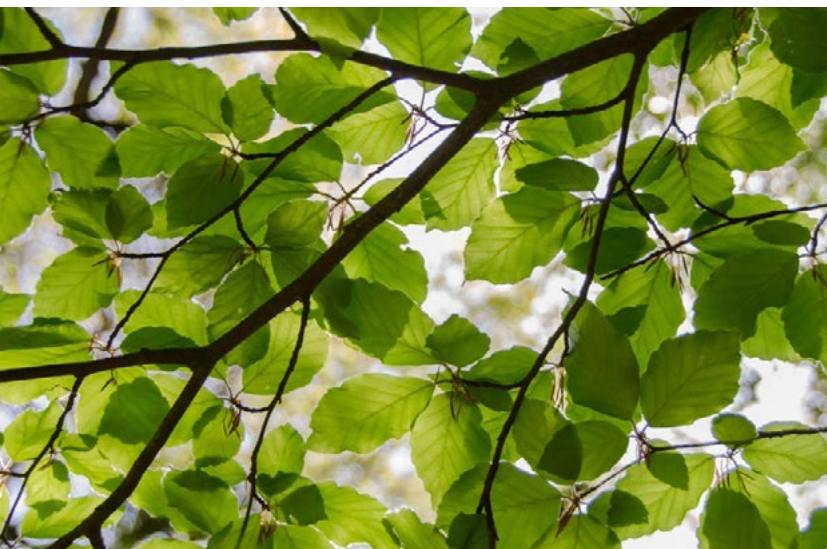

HRV Duct Cover

HRV Accessories

For use with Titon HRV units

HRV Duct Covers are designed to conceal the ducting/silencers from the ports at the top of the unit to the ceiling of the property. The ducting cover also helps reduce ducting breakout noise levels into the room. This both improves the overall appearance of the installation and the noise levels.

The covers match the high quality construction and finish of the HRV units and can be easily installed. Access to the control box and ducting can be achieved easily by the removal of the front panel of the ducting covers.

The covers have an adjustable height of 300mm to 400mm so that variations in height of the unit to the ceiling can be accommodated. The covers are suitable for use with rigid or flexible ducting options, and also Titon's semi-rigid duct attenuators.

There are two types of design of covers, one that is flush with the profile of the units leaving a small area at the ceiling for the ducting to pass through and the other opens up at the ceiling so that round to rectangular elbows can be used.

Product Codes

Model	Part Number	Part Number
	Straight	Flared
HRV1.25, 1.35	TP585	TP577
HRV1.6, 1.65	TP589	TP588
HRV1.75, 2, 2.85, 3	TP586	TP578
HRV4, 4.25	TP706	TP707
HRV10M, 10.25M	TP587	TP579

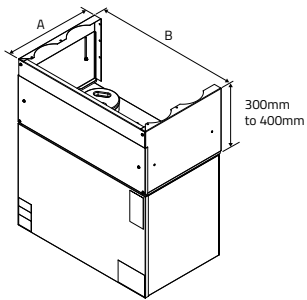

Product Code	A	B	Weight (kg)
TP585	321	657	7
TP589	366	598	6.9
TP586	426	707	7.5
TP706	485	600	7.5
TP587	473	795	8

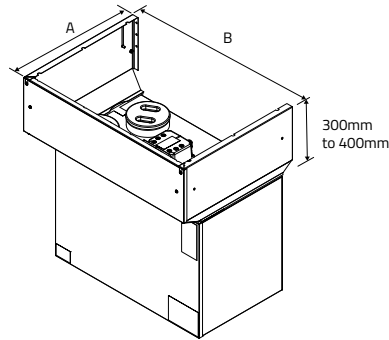

Product Code	A	B	Weight (kg)
TP577	419	704	8
TP588	479	687	8.8
TP578	539	795	9.6
TP707	539	795	9.2
TP579	539	795	10

Accessory



Straight Duct Cover



Flared Duct Cover

HRV First Fix Solutions

HRV Accessories

For use with Titon HRV units

HRV First Fix Solutions are designed to make installation of the ducting from the ceiling void to the unit easier and give a high quality finish. This will reduce the installation time and complete the overall appearance of the installation.

The First Fix Solutions match the construction, quality and finish of the HRV units and can be easily installed into the property. The first fix solutions are designed to be used in conjunction with Titon's 90° elbows with either the Ø150 round to round ports or the Ø150 round to rectangular 220x90 ports.

There are two first fix solutions (small & large) which can be used with Titon's HRV 1.6 – 3 units. The small first fix solution is designed to have the same face area as the top of the unit so that the ducting from the unit travels directly to the ports in the first fix. This solution requires the use of Ø150 round to round elbows in the ceiling void due to the closeness of the ports.

Accessory

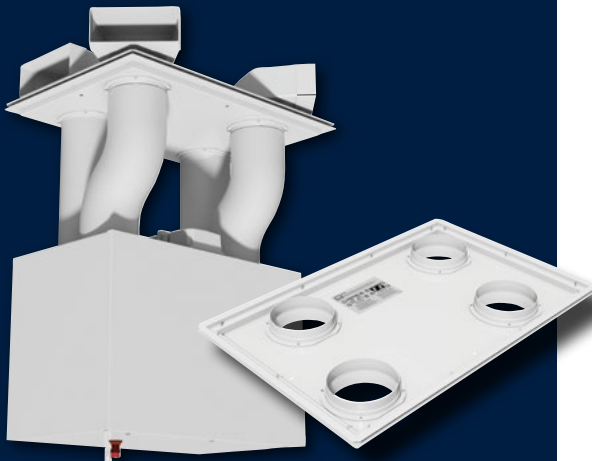

Product Codes

Small First Fix Solution (Ø150 to Ø150)

TP575 - HRV 1.75, 2, 2.85 and 3 Q Plus

TP576 - HRV 1.6 Q Plus

Large First Fix Solution (Ø150 to 220x90)

TP591 - HRV 1.75, 2, 2.85 and 3 Q Plus

TP592 - HRV 1.6 Q Plus

The **large first fix** solution is the same width as the unit, but greater in depth which allows the use of Ø150 round to rectangular 220x90 elbows and therefore can be fitted in a lower ceiling void. The 90° elbows are not sold as part of the kit and should be purchased from Titon separately.

TP575 - HRV 1.75-10.25 Small First Fix

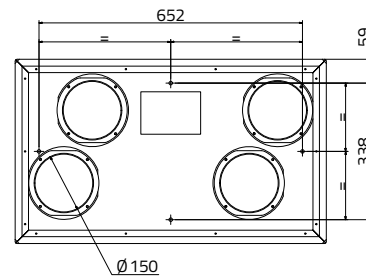

TP591 - HRV 1.75-10.25 Large First Fix

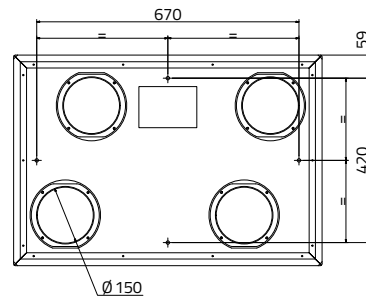

TP576 - HRV 1.6 Small First Fix

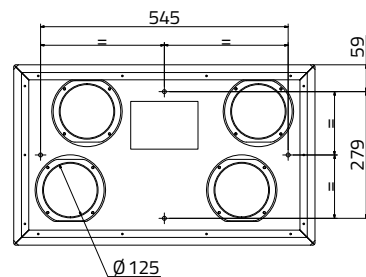

TP592 - HRV 1.6 Large First Fix

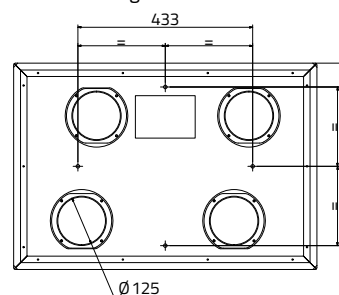

HRV AV Mounting Kits

HRV Accessories

For use with Titon HRV units

HRV Anti-Vibration (AV) units have been specifically designed to isolate the unit from the wall to further reduce any low levels of vibration induced noise from being transmitted to the mounting structure.

The AV mounting brackets match the construction, quality and finish of the HRV units in addition to the standard fixings supplied without obstructing any subsequently attached ducting.

The use of 4 rubber AV bobbins per mounting kit have been specifically selected to give the best performance whilst the bracket design keeps the unit close to the mounting surface. This means the AV mounting kits can be retrofitted to existing unit installations using the existing fixing points.

Please note: AV brackets cannot be retro fitted on units with the double flap hinged wiring cover.

Product Codes

Model AV Mounting Kit	Part Number
HRV1.25, 1.35	TP570
HRV1.6	TP598
HRV1.75, 2, 2.85, 3	TP571
HRV10, 10.25	TP572
HRV10M, 10.25M	TP573

Accessory

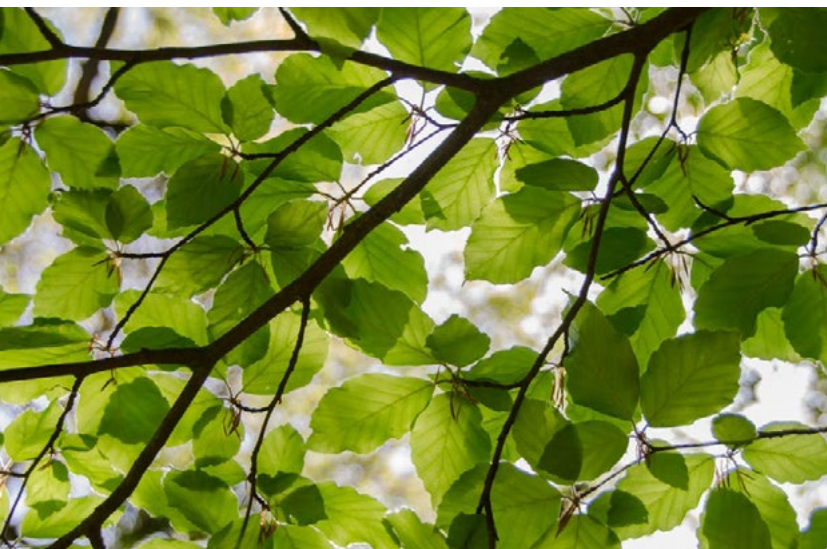

Duct Pre-heater

HRV Accessories

For use with Titon HRV units

Titon's Duct Pre-Heaters are designed to heat clean air in conjunction with Titon's HRV cold climate ventilation units.

Duct Pre-Heaters uses include tempering fresh air in ventilation systems, supplying heated air to rooms and boosting supply air temperature in heat recovery units - including Titon's Passivhaus approved MVHR unit.

Casings are made from aluzinc coated steel, which is ideal for high temperature. Heating elements tubing is made from stainless steel AISI 304.

All Duct Pre-Heaters are installed with 2 protection thermostats, screw terminals for easy connection and rubbers seals to fit to ducting.

Features & Benefits

- Built in temperature control
- Aluzinc casing
- Stainless steel heating elements
- Rolled rubber seals for duct connection
- Two stage overheat protection
- Built in temperature control
- Manual reset button when temperature reaches 100°C
- Compatible with Titon's cold climate HRV units
- IP44 Rating
- To be used with metal ducting only

All Duct Pre-Heaters have two-stage overheat protection:

1. The first stage switches on when the temperature reaches 50°C (resets automatically).
2. The second stage switches on when the temperature reaches 100°C (is reset manually with push button on the casing).

Heaters can be installed vertically or horizontally. Maximum output air temperature 50°C.

Designed for installation in metal ducting. There must be a minimum clearance of 50mm to any combustible material.

Heater

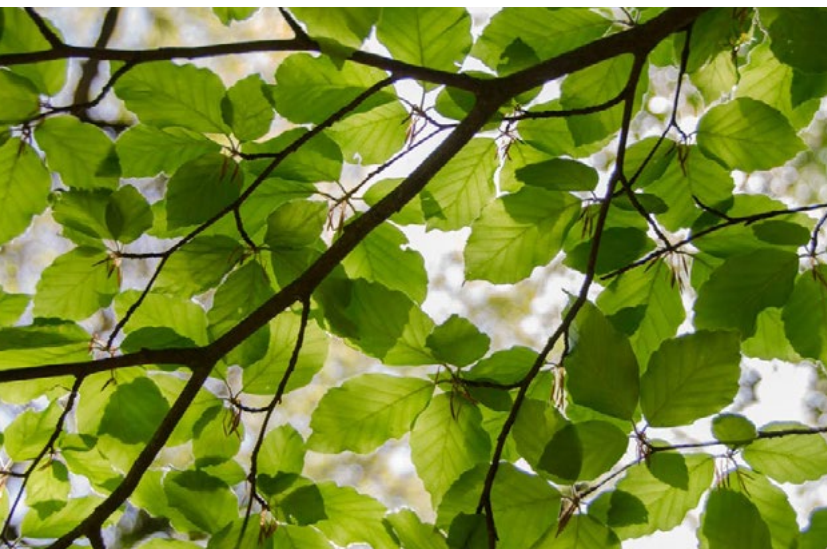

Temperature control



Temperature Sensor

Product Codes

EKA-NV125-0.9 – Ø125mm 0.9kW electric Duct Pre-heater with temperature control, including remote duct temperature sensor

EKA-NV125-1.5 – Ø125mm 1.5kW electric Duct Pre-heater with temperature control, including remote duct temperature sensor

EKA-NV150-1.5 – Ø160mm 1.5kW electric Duct Pre-heater with temperature control, including remote duct temperature sensor

EKA-NV160-1.2 – Ø160mm 1.2kW electric Duct Pre-heater with temperature control, including remote duct temperature sensor

EKA-NV160-1.5 – Ø160mm 1.5kW electric Duct Pre-heater with temperature control, including remote duct temperature sensor

Specification

Dimensions: 370mm length, diameter plus 32mm height.

Material: Aluzinc casing

Guarantee period: 2 years

Electrical: 230V ~ 50/60Hz

Installation: To be installed accordance with the relevant and applicable building regulations.

Please refer to our cold temperature MVHR product manual for further guidance on installation.

Drawing & Dimensions

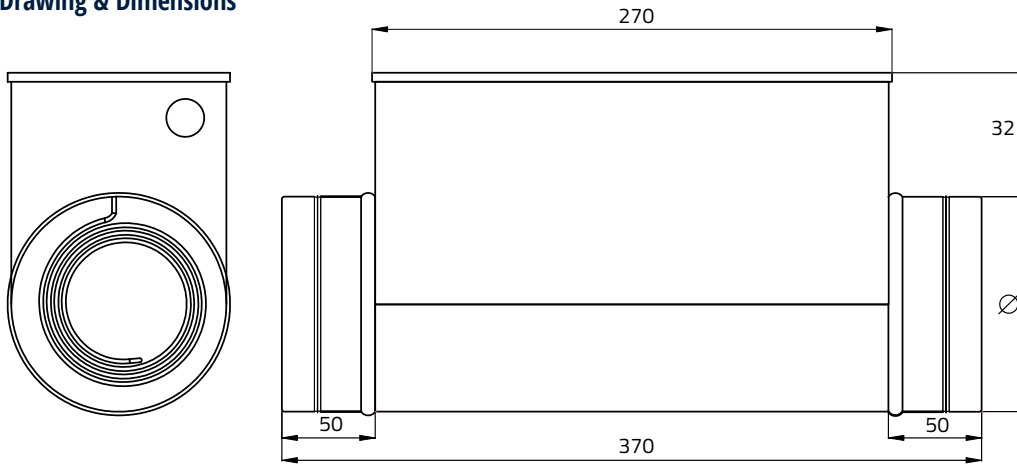

Dimensions in mm

Performance Details

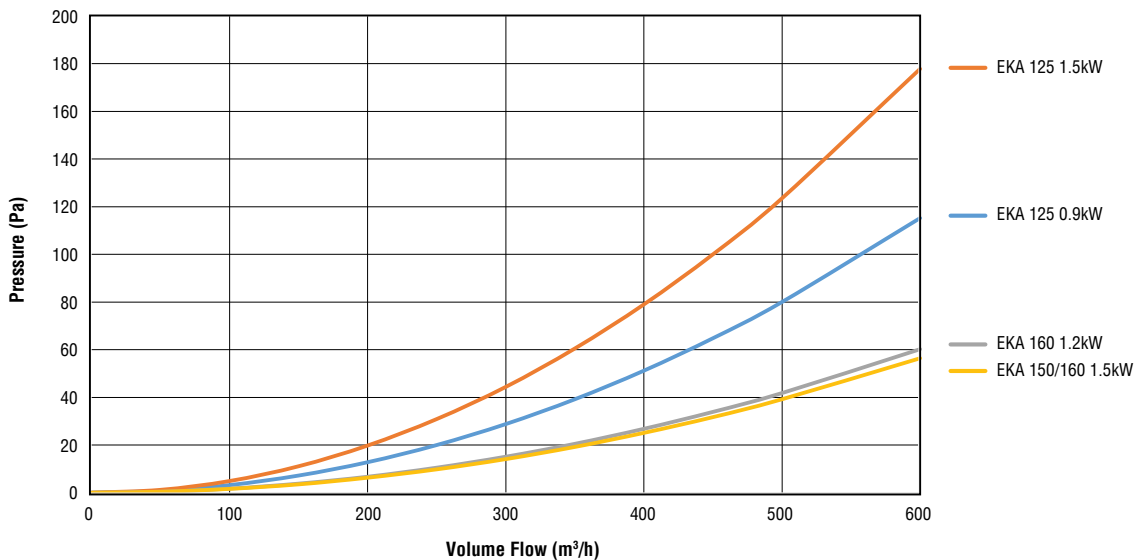

Product Type	Diameter	Min. Airflow (m³/h)	Min. Airflow (l/s)	Voltage (50 Hz)	Power kW
EKA-NV125-0.9	125	70	19	1-230	0.9
EKA-NV125-1.5	125	70	19	1-230	1.5
EKA-NV150-1.5	160	110	30	1-230	1.5
EKA-NV160-1.2	160	110	30	1-230	1.2
EKA-NV160-1.5	160	110	30	1-230	1.5

CME2 Q Plus

Continuous Mechanical Extract

For use in dwellings with six wet rooms or fewer

The CME2 Q Plus is ideal for continuous extract of stale, damp and polluted air to the outside environment.

The combination of aesthetic smooth lines, unique tilted impeller and single level ports provides the ideal solution for hidden ceiling installation in flats and apartments.

The unit has a very large duty range over 116l/s (418 m³/hr) at 200 Pa.

MEV

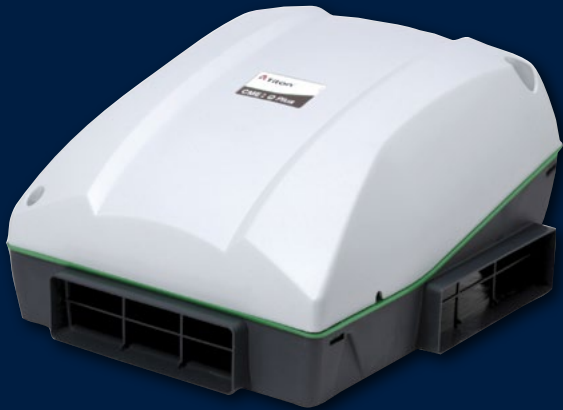

For use with Titon Trickle Ventilators.

Features & Benefits

- High energy efficiency levels, via Electronically Commutated (EC) motor
- Very low power consumption/specific fan power
- Airflow up to 137 l/s (493 m³/h) at 100 Pa
- Compact – unit is small and low in profile, can be fitted in airing cupboards, cupboards or loft spaces
- Easy installation due to innovative sub-assembly and unique packaging design
- Optional two part installation
- Performs to high levels through rectangular ports; does away with need for round to rectangular adaptors, saving cost, reducing joints and installation time
- Optional adjustable humidity sensor (between 55% RH & 85% RH) triggers boost speed proportionally
- Duct ports on one level, lessening need for unnecessary bends in ducting, saving cost, reducing joints and installation time
- Ideal for central mechanical ventilation in refurbishment of single floor dwellings where there is only space for rectangular ducting
- Low unit noise
- Fully adjustable boost overrun timer 0-30 minutes
- Can accept either 204mm x 60mm (standard) or 110mm x 54mm ducting (using provided converter)
- Unit can be cleaned and serviced without disturbing ducting
- Original enclosure design with 204mm x 60mm spigots on one level, ideal for low profile ceiling mounting
- For use in conjunction with Titon trickle vents
- Available in volt free and switch live inputs
- Hidden fixings
- Quick and easy commissioning
- Demand control ventilation ready
- Wide duty range
- Patent applied
- Can be mounted on any plane



Description

Titon CME2 Q Plus whole-house central mechanical extract ventilation unit.

Product Codes

TP325 CME base only (First fix).

Volt free switch inputs

TP302A CME 2 Q Plus (Full assembly).

TP302HA CME 2 Q Plus, humidity sensor (Full assembly).

TP303A CME 2 Q Plus Fan assembly only (Second fix).

TP303HA CME 2 Q Plus Fan assembly only, humidity sensor (Second fix).

Switch live inputs

TP304HA CME 2 Q Plus, humidity sensor (Full assembly).

TP305HA CME 2 Q Plus Fan assembly only, humidity sensor (Second fix).

Standards

Conforms to requirements of UK statutory Building Regulations and Technical Standards for Ventilation and BRE 398.

SAP Appendix Q tested.

Exceeds requirements of Building Regulations Approved Document L (England & Wales).

EU RoHS Directive compliant.

Conforms to requirements of EC council directives relating to Electromagnetic Compatibility and Electrical Safety:

2006/95/EC (LVD), 2004/108/EC (EMC) EN 60335-1:2002/A2:2006, EN 60335-2-80:2003, A1:2004.

CE and UKCA marked.

Other non-UK info available on request.

Specification

Dimensions (excluding ports):

355mm wide x 421mm long x 252mm high

Weight: 5kg

Finish: Light grey / dark grey

Materials:

Housing: Talc Filled Polypropylene

Guarantee period: 3 years (UK only)

Electrical: 230V ~ 50/60Hz, 3A fuse

Installation: To be installed accordance with the relevant and applicable building regulations.

Maintenance: See product manual.

Acoustics: Full acoustic data available online www.titon.com/acoustics.

Drawing & Dimensions

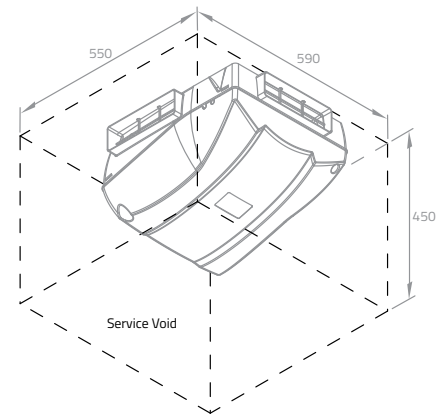
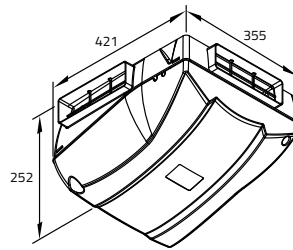

Dimensions (excluding ports)

Dimensions in mm

Performance

The figures and compliance levels below relate to current SAP requirements. Revised SAP guidance will have an effect on performance and up-to-date figures can be found on the relevant product page at www.titon.com.

Exhaust terminal configuration*	Fan speed setting	SFP (W/l/s)	SFP (W/l/s)
		2009	2012
Kitchen + 1 additional wet room	100% variable	0.2	0.2
Kitchen + 2 additional wet rooms	100% variable	0.17	0.17
Kitchen + 3 additional wet rooms	100% variable	0.19	0.19
Kitchen + 4 additional wet rooms	100% variable	0.21	0.21
Kitchen + 5 additional wet rooms	100% variable	0.25	0.25
Kitchen + 6 additional wet rooms	100% variable	0.29	0.29

Figures taken from the BRE Test Results apply for both the standard and humidity versions.

*Number of wet rooms is based on SAP Q test criteria and does not correlate directly with regulatory performance requirements. Test results available for use with 110 x 54mm ducting.

Nominal Fan Performance

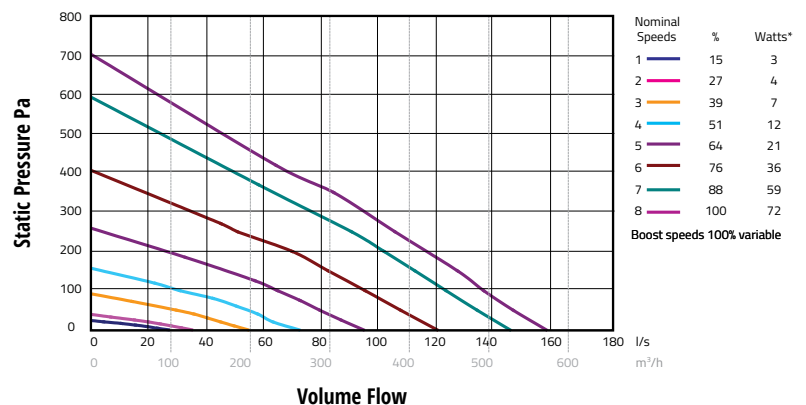

Acoustic Data

Product	Airflow l/s	% of Max flow	dB(A) @ 3m Hemispherical		dB(A) @ 3m Spherical
			Induct Inlet	Casing Breakout	Casing Breakout
CME2 Q Plus	36l/s	41%	20	23	20
	57l/s	65%	33	33	30
	85l/s	100%	42	41	38

For full frequency acoustic data at various speeds please see www.titon.com. All acoustic data is third party tested at Sound Research Laboratories (SRL) Ltd.

CME2.1 Q Plus

Continuous Mechanical Extract

For use in dwellings with six wet rooms or fewer

The CME2.1 Q Plus is ideal for continuous extract of stale, damp and polluted air to the outside environment.

The combination of aesthetic smooth lines, unique tilted impeller and single level ports provides the ideal solution for hidden ceiling installation in flats and apartments.

The unit has a very large duty range over 113 l/s (405 m³/hr) at 200 Pa.

MEV

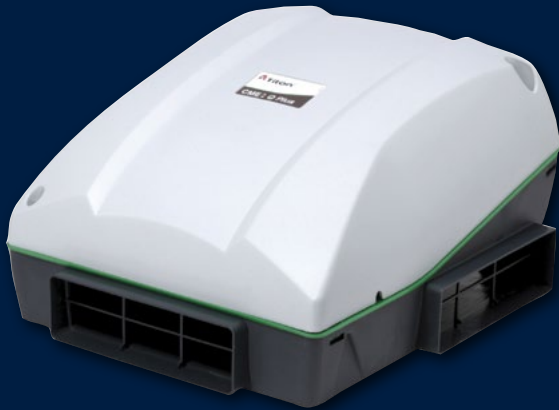

For use with Titon Trickle Ventilators.

auralite CME



Features & Benefits

- High energy efficiency levels, via Electronically Commutated (EC) motor
- Very low power consumption/specific fan power
- Airflow up to 123 l/s (445 m³/h) at 100 Pa
- Compact – unit is small and low in profile, can be fitted in airing cupboards, cupboards or loft spaces
- Easy installation due to innovative sub-assembly and unique packaging design
- Optional two part installation
- Performs to high levels through rectangular ports; does away with need for round to rectangular adaptors, saving cost, reducing joints and installation time
- Optional adjustable humidity sensor (between 55% RH & 85% RH) triggers boost speed proportionally
- Duct ports on one level, lessening need for unnecessary bends in ducting, saving cost, reducing joints and installation time
- Ideal for central mechanical ventilation in refurbishment of single floor dwellings where there is only space for rectangular ducting
- Low unit noise
- Fully adjustable boost overrun timer 0-30 minutes
- Can accept either 204mm x 60mm (standard) or 110mm x 54mm ducting (using provided converter)
- Unit can be cleaned and serviced without disturbing ducting
- Original enclosure design with 204mm x 60mm spigots on one level, ideal for low profile ceiling mounting
- For use in conjunction with Titon trickle vents
- Available in volt free and switch live inputs
- Hidden fixings
- Quick and easy commissioning
- Demand control ventilation ready
- Wide duty range
- Patent applied
- Can be mounted on any plane



Description

Titon CME2.1 Q Plus whole-house central mechanical extract ventilation unit.

Product Codes

TP325 - CME base only (First fix).

Volt free switch inputs

TP312A - CME 2.1 Q Plus (Full assembly).

TP312HA - CME 2.1 Q Plus, humidity sensor (Full assembly).

TP313A - CME 2.1 Q Plus (Second fix).

TP313HA - CME 2.1 Q Plus, humidity sensor (Second fix).

Switch live inputs

TP312HALS - CME 2.1 Q Plus, humidity sensor, switch live inputs (Full assembly).

TP313HALS - CME 2.1 Q Plus, humidity sensor, switch live inputs (Second fix).

Indicator Ready (auralite® CME TP517)

TP312CH - CME 2.1 Q Plus, humidity sensor, controls ready (Full assembly).

TP313CH - CME 2.1 Q Plus, humidity sensor, controls ready (Second fix).

Standards

Conforms to requirements of UK statutory Building Regulations and Technical Standards for Ventilation and BRE 398.

SAP Appendix Q tested.

Exceeds requirements of Building Regulations Approved Document L (England & Wales).

EU RoHS Directive compliant.

Conforms to requirements of EC council directives relating to Electromagnetic Compatibility and Electrical Safety:

2006/95/EC (LVD), 2004/108/EC (EMC) EN 60335-1:2002/A2:2006, EN 60335-2-80:2003, A1:2004.

CE and UKCA marked.

Other non-UK info available on request.

Specification

Dimensions (excluding ports):

355mm wide x 421mm long x 252mm high

Weight: 5kg

Finish: Light grey / dark grey

Materials:

Housing: Talc Filled Polypropylene

Guarantee period: 3 years (UK only)

Electrical: 230V ~ 50/60Hz, 3A fuse

Installation: To be installed accordance with the relevant and applicable building regulations.

Maintenance: See product manual.

Acoustics: Full acoustic data available online www.titon.com/acoustics.

Drawing & Dimensions

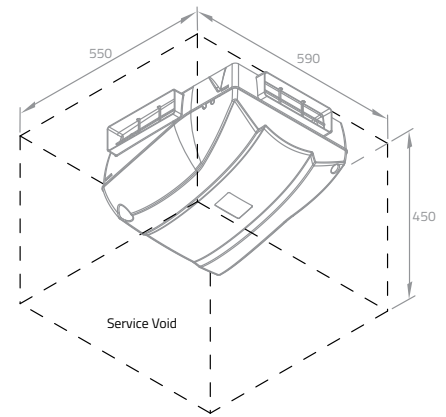
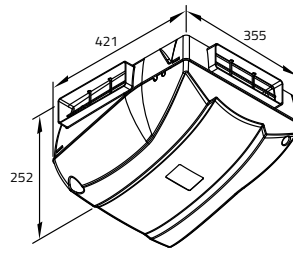

Dimensions (excluding ports)

Dimensions in mm

Performance

The figures and compliance levels below relate to current SAP requirements. Revised SAP guidance will have an effect on performance and up-to-date figures can be found on the relevant product page at www.titon.com.

Exhaust terminal configuration*	Fan speed setting	SFP (W/l/s)	SFP (W/l/s)
		2009	2012
Kitchen + 1 additional wet room	100% variable	0.20	0.20
Kitchen + 2 additional wet rooms	100% variable	0.18	0.18
Kitchen + 3 additional wet rooms	100% variable	0.20	0.20
Kitchen + 4 additional wet rooms	100% variable	0.22	0.22
Kitchen + 5 additional wet rooms	100% variable	0.28	0.28
Kitchen + 6 additional wet rooms	100% variable	0.33	0.33

Figures taken from the BRE Test Results apply for both the standard and humidity versions.

*Number of wet rooms is based on SAP Q test criteria and does not correlate directly with regulatory performance requirements. Test results available for use with 110 x 54mm ducting.

Nominal Fan Performance

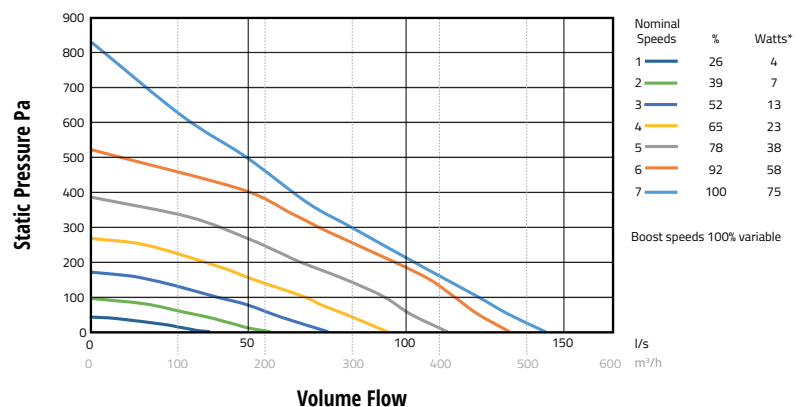

Acoustic Data

Product	Airflow l/s	% of Max flow	dB(A) @ 3m Hemispherical		dB(A) @ 3m Spherical
			Induct Inlet	Casing Breakout	Casing Breakout
CME2.1 Q Plus	36l/s	41%	19	25	22
	60l/s	68%	31	38	35
	88l/s	100%	40	47	44

For full frequency acoustic data at various speeds please see www.titon.com. All acoustic data is third party tested at Sound Research Laboratories (SRL) Ltd.

CME3 Q Plus

Continuous Mechanical Extract

For use in dwellings with six wet rooms or fewer

The new CME3 Q Plus is ideal for continuous extract of stale, damp and polluted air to the outside environment.

The CME3 Q Plus is the latest addition to the centralised mechanical extract unit range. The combination of aesthetic smooth lines and a low profile makes it the ideal solution for hidden ceiling installation in flats and apartments.

The unit has a very large duty range over 104l/s (376 m³/hr) at 200 Pa.

Features & Benefits

- High energy efficiency levels, via Electronically Commutated (EC) motor
- Very low power consumption/specific fan power
- Airflow up to 120l/s (430 m³/h) at 100 Pa
- Compact – unit is small and low in profile, can be fitted in airing cupboards, cupboards or loft spaces
- Easy installation due to innovative sub-assembly and unique packaging design
- Optional adjustable humidity sensor (between 55% RH & 85% RH) increases unit's speed proportionally
- Low unit noise
- Fully adjustable boost overrun timer 0-30 minutes
- Can accept either Ø125 and/or Ø100
- Unit can be cleaned and serviced without disturbing ducting
- For use in conjunction with Titon trickle vents
- Available in volt free and switch live inputs
- Quick and easy commissioning
- Demand control ventilation ready
- Wide duty range
- Can be mounted on any plane



For use with Titon Trickle Ventilators.



Description

Titon CME3 Q Plus whole-house central mechanical extract ventilation unit.

Product Codes

Volt free switch inputs

TP332A CME3 Q Plus (Full assembly).

TP332HA CME3 Q Plus, humidity sensor (Full assembly).

Switch live inputs

TP334HA CME3 Q Plus, humidity sensor, switch live inputs (Full assembly).

Standards

Conforms to requirements of UK statutory Building Regulations and Technical Standards for Ventilation and BRE 398.

SAP Appendix Q tested.

Exceeds requirements of Building Regulations Approved Document L (England & Wales).

EU RoHS Directive compliant.

Conforms to requirements of EC council directives relating to Electromagnetic Compatibility and Electrical Safety:

2006/95/EC (LVD), 2004/108/EC (EMC) EN 60335-1:2002/A2:2006, EN 60335-2-80:2003, A1:2004.

CE and UKCA marked.

Other non-UK info available on request.

Specification

Dimensions (excluding ports):

310mm wide x 340mm long x 252mm high (excluding spigots)

Weight: 5 kg

Finish: Light grey / dark grey

Materials:

Housing: Talc Filled Polypropylene

Guarantee period: 3 years (UK only)

Electrical: 230V ~ 50/60Hz, 3A fuse

Installation: To be installed accordance with the relevant and applicable building regulations.

Maintenance: See product manual.

Acoustics: Full acoustic data available online www.titon.com/acoustics.

Drawing & Dimensions

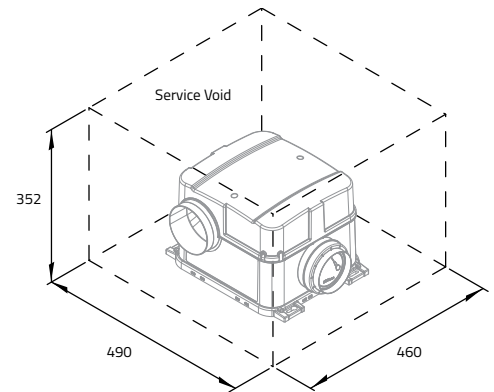
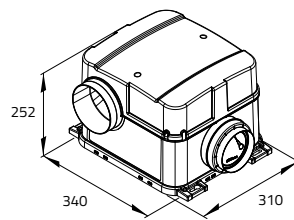

Dimensions (excluding ports)

Dimensions in mm

Performance

The figures and compliance levels below relate to current SAP requirements. Revised SAP guidance will have an effect on performance and up-to-date figures can be found on the relevant product page at www.titon.com.

Exhaust terminal configuration*	Fan speed setting	SFP (W/l/s)	SFP (W/l/s)
		2009	2012
Kitchen + 1 additional wet room	100% variable	0.18	0.18
Kitchen + 2 additional wet rooms	100% variable	0.16	0.16
Kitchen + 3 additional wet rooms	100% variable	0.17	0.17
Kitchen + 4 additional wet rooms	100% variable	0.19	0.19
Kitchen + 5 additional wet rooms	100% variable	0.21	0.21
Kitchen + 6 additional wet rooms	100% variable	0.25	0.25

Figures taken from the BRE Test Results apply for both the standard and humidity versions.

*Number of wet rooms is based on SAP Q test criteria and does not correlate directly with regulatory performance requirements. Test results available for use with 110mm ducting.

Nominal Fan Performance

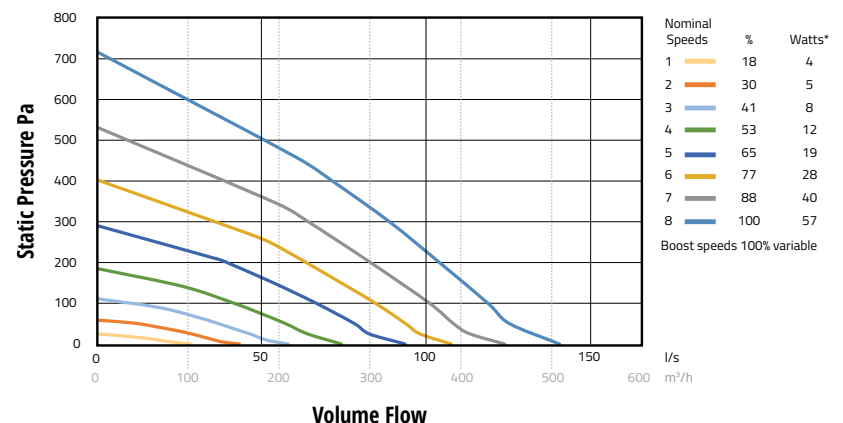

Acoustic Data

Product	Airflow l/s	% of Max flow	dB(A) @ 3m Hemispherical		dB(A) @ 3m Spherical
			Induct Inlet	Casing Breakout	Casing Breakout
CME3 Q Plus	42l/s	41%	19	21	18
	69l/s	65%	35	32	29
	104l/s	100%	44	45	42

For full frequency acoustic data at various speeds please see www.titon.com. All acoustic data is third party tested at Sound Research Laboratories (SRL) Ltd.

CME3.1 Q Plus

Continuous Mechanical Extract

For use in dwellings with six wet rooms or fewer

The new CME3.1 Q Plus is ideal for continuous extract of stale, damp and polluted air to the outside environment.

The CME3.1 Q Plus is the latest addition to the centralised mechanical extract unit range. The combination of aesthetic smooth lines and a low profile makes it the ideal solution for hidden ceiling installation in flats and apartments.

The unit has a very large duty range over 103l/s (371 m³/hr) at 200 Pa

Features & Benefits

- High energy efficiency levels, via Electronically Commutated (EC) motor
- Very low power consumption/specific fan power
- Airflow up to 124 l/s (445 m³/h) at 100 Pa
- Compact – unit is small and low in profile, can be fitted in airing cupboards, cupboards or loft spaces
- Easy installation due to innovative sub-assembly and unique packaging design
- Optional adjustable humidity sensor (between 55% RH & 85% RH) increases unit's speed proportionally
- Low unit noise
- Fully adjustable boost overrun timer 0-30 minutes
- Can accept either Ø125 and/or Ø100
- Unit can be cleaned and serviced without disturbing ducting
- For use in conjunction with Titon trickle vents
- Available in volt free and switch live inputs
- Quick and easy commissioning
- Demand control ventilation ready
- Wide duty range
- Can be mounted on any plane

MEV



For use with Titon Trickle Ventilators.

auralite CME



Description

Titon CME3.1 Q Plus whole-house central mechanical extract ventilation unit.

Product Codes

Volt free switch inputs

TP342A - CME3.1 Q Plus (Full assembly)

TP342HA - CME3.1 Q Plus, humidity sensor (Full assembly)

Switch live inputs

TP342HALS - CME3.1 Q Plus, humidity sensor, switch live inputs (Full assembly).

Indicator Ready (auralite® CME TP517)

TP342CH - CME 3.1 Q Plus, humidity sensor, controls ready (Full assembly).

Standards

Conforms to requirements of UK statutory Building Regulations and Technical Standards for Ventilation and BRE 398.

SAP Appendix Q tested.

Exceeds requirements of Building Regulations Approved Document L (England & Wales).

EU RoHS Directive compliant.

Conforms to requirements of EC council directives relating to Electromagnetic Compatibility and Electrical Safety:

2006/95/EC (LVD), 2004/108/EC (EMC) EN 60335-1:2002/A2:2006, EN 60335-2-80:2003, A1:2004.

CE and UKCA marked.

Other non-UK info available on request.

Specification

Dimensions (excluding ports):

310mm wide x 340mm long x 252mm high (excluding spigots)

Weight: 5 kg

Finish: Light grey / dark grey

Materials:

Housing: Talc Filled Polypropylene

Guarantee period: 3 years (UK only)

Electrical: 230V ~ 50/60Hz, 3A fuse

Installation: To be installed accordance with the relevant and applicable building regulations.

Maintenance: See product manual.

Acoustics: Full acoustic data available online www.titon.com/acoustics.

Drawing & Dimensions

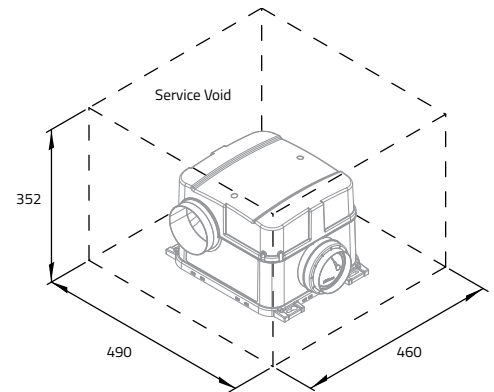
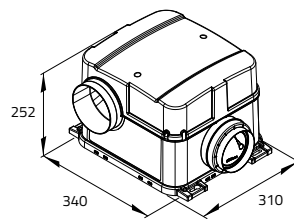

Dimensions (excluding ports)

Dimensions in mm

Performance

The figures and compliance levels below relate to current SAP requirements. Revised SAP guidance will have an effect on performance and up-to-date figures can be found on the relevant product page at www.titon.com.

Exhaust terminal configuration*	Fan speed setting	SFP (W/l/s)	SFP (W/l/s)
		2009	2012
Kitchen + 1 additional wet room	100% variable	0.17	0.17
Kitchen + 2 additional wet rooms	100% variable	0.16	0.16
Kitchen + 3 additional wet rooms	100% variable	0.17	0.17
Kitchen + 4 additional wet rooms	100% variable	0.20	0.20
Kitchen + 5 additional wet rooms	100% variable	0.23	0.23
Kitchen + 6 additional wet rooms	100% variable	0.26	0.26

Figures taken from the BRE Test Results apply for both the standard and humidity versions.

*Number of wet rooms is based on SAP Q test criteria and does not correlate directly with regulatory performance requirements. Test results available for use with 110mm ducting.

Nominal Fan Performance

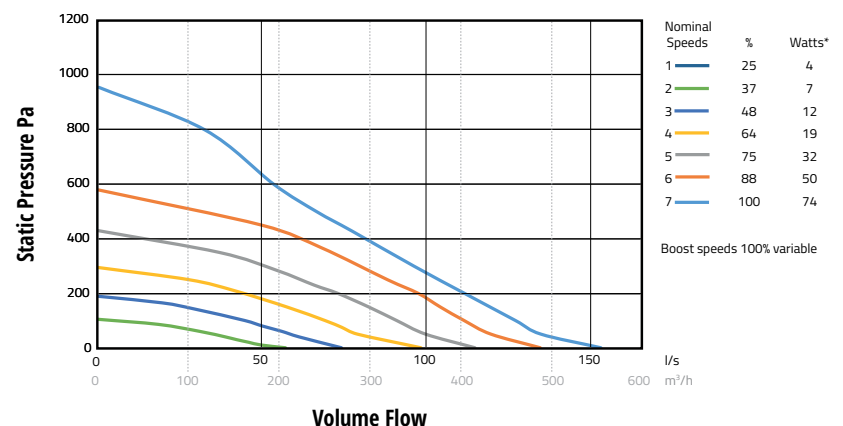

Acoustic Data

Product	Airflow l/s	% of Max flow	dB(A) @ 3m Hemispherical		dB(A) @ 3m Spherical
			Induct Inlet	Casing Breakout	Casing Breakout
CME3.1 Q Plus	42l/s	40%	19	18	15
	71l/s	68%	37	29	26
	105l/s	100%	43	39	36

For full frequency acoustic data at various speeds please see www.titon.com. All acoustic data is third party tested at Sound Research Laboratories (SRL) Ltd.

Titon Ultimate® dMEV

Decentralised Mechanical Extract Ventilation
or constant flow intermittent extract fan

For use in residential dwellings and light commercial applications

The new high performing Titon Ultimate® dMEV is an ultra quiet low profile fan, which is suitable for new build or refurbishment projects. It can be either wall or ceiling mounted and is ideal for bathrooms, kitchens and utility room applications.

With adjustable continuous and boost speed settings available. The patent applied fan utilises an efficient DC motor and uniquely designed impeller/guide vane combination to produce high flow rates and pressure.

The Titon Ultimate® dMEV uses a boost overrun and boost delay timer that is adjustable between 0 - 60 minutes. The unit has optional humidity control, constant flow and optional data logging.

dMEV



For use with Titon Trickle Ventilators.

Features & Benefits

- One of the quietest solutions and best performing dMEV fan on the market
- PCDB listed for inclusion within SAP (Consp10/SAP10 compliant)
- Low specific fan power down to 0.11 W/l/s
- Airflow up to 30 l/s (108 m³/h)
- Extremely low running costs
- 3 configurable speed options (Trickle, Boost and High Boost)
- Eligible for Energy Compliance Obligation (ECO) fourth iteration funding
- Constant flow technology
- 4 button & LED display to allow for simple control
- Extract fan designed to run continuously (24/7)
- Integral pressure sensor to maintain constant flow to overcome external back pressures of up to 20Pa
- Unit running time and average RH Data Logging
- Fast straightforward commissioning and set up
- CFC Ceiling Fan Cuff available. Independently tested to BS EN 1364-2: 2018 Fire Resistance Tests for non-load bearing elements – Part 2: Ceilings and additional guidance from BS EN 1366-3: 2009. (Test Report 510322B/R). Up to 60 minutes integrity and insulation
- Ideal for removing condensation which can lead to mould and ill health
- Low profile aesthetic circular design
- Quiet running, only 10 dB(A) at 3m, low speed
- Unique high performance impeller and guide vane design
- IPX4 rated (Ceiling mounted TP646 Kit required)*
- Double insulated (requires no earth)
- Designed and manufactured in accordance with EN60335-2-80 Low Voltage Directive and the EMC Directive (Electromagnetic Compatibility)
- Display in l/s or m³/h
- Intermittent function
- Humidity control suspend timer
- Unit lock out button for installers/landlords
- Complies with Building Regulations Part F (England and Wales)
- Exceeds newly proposed stringent 20 Pa back pressure requirement

* To maintain the IPX4 rating when ceiling mounted, a kit must be used. Please contact Titon for availability of ceiling mounting kits.



The Ultimate Choice

Description

Titon Ultimate® dMEV constant flow decentralised mechanical extract ventilation fan.

Product Codes

TP640i – Basic version

TP640Hi – Humidity Control

TP640Hdi – Humidity Control with Data Logging

Standards

Designed and manufactured in accordance with EN60335-2-80 (Low Voltage Directive) and the EMC Directive (Electromagnetic Compatibility).

Air performance measured according to ISO 5801 at 230V 50Hz, air density 1,2 Kg/m³. CE and UKCA marked.

Specification

Dimensions: Ø195mm with 45mm projection

Weight: 0.5Kg

Finish: Gloss White

Materials: ABS, PCB's, LED display & brushless motor.

Controls: Onboard 4 button controls with 4 digit LED display

Guarantee period: 18 months (UK only)

Electrical: 220-240 V ~ 50/60Hz

Installation: To be installed accordance with the relevant and applicable building regulations.

Maintenance: Service, clean, replace subject to local environment - see product manual.

Accessories

TP645/BR - Telescopic Wall Kit (Brown)

TP645/BE - Telescopic Wall Kit (Beige)

TP645/TC - Telescopic Wall Kit (Terracotta)

TP645/WH - Telescopic Wall Kit (White)

TP646 - IPx4 Ceiling Kit

TP647 - Decorative Wall Plate

CFC100 - CFC Ceiling Fan Cuff

QSS310 - Quelstop Acrylic Sealant

Ducting Kits

Our ducting kits are recommended to maintain flow rates and are available in Ø100mm and 110x54mm rectangular. Kits contain; 3m duct, bends, grille and accessories. Calculated resistance rates are also included in ducting kit literature.

Drawing & Dimensions

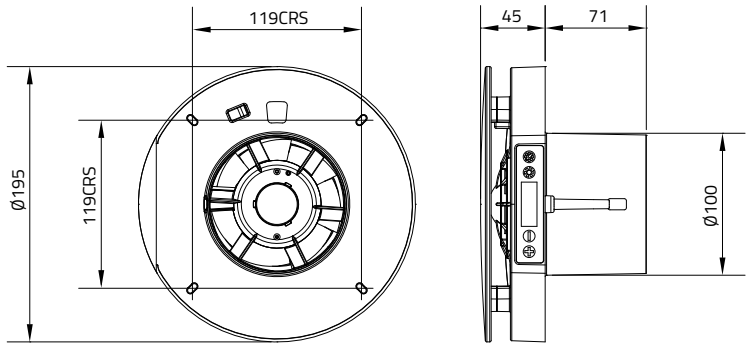

CRS - Fixing Holes

Dimensions (excluding ports) in mm

Ceiling IPX4 Kit*
(TP646)

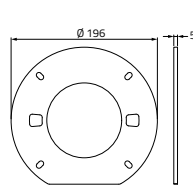

Decorative Wall Plate
(TP647)

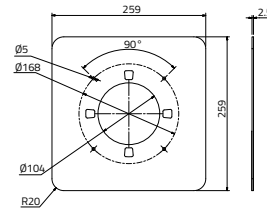

* To be used with Window Kits TP203 & TP204

Performance

The results detailed below have been determined from independent laboratory testing performed in accordance with the latest SAP10 dMEV (Consp10) test standard introduced on 15th June 2022. Tests were performed with rigid ducting.

		Ducted in Room					Through Wall	
		Kitchen		Wet Room			Kitchen	Wet Room
Fan Speed Setting	l/s	13	16	5	8	11	13	8
SFP	w/l/s	0.15	0.16	0.21	0.15	0.15	0.11	0.14
Volume reduction with 20Pa back pressure	%	1	2	6	5	2	1	1
Max volume reduction allowed	%	30	30	30	30	30	30	30
Power	W	1.89	2.52	1.07	1.23	1.60	1.47	1.13
Noise Level	dBA @ 3m	28**		19**			26	15

Figures taken from the BRE Test Results.

**Using 100mm diameter round duct and tested in accordance with SAP PCDB method V2.0:2013.

Nominal Fan Performance

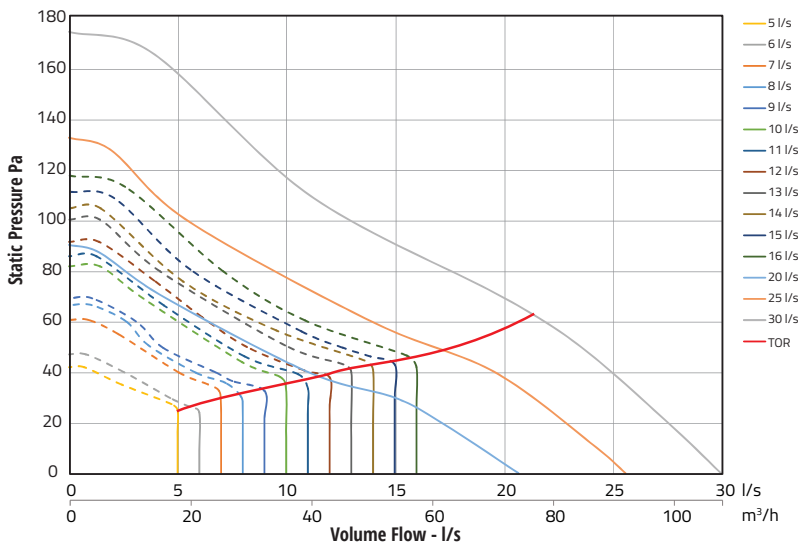

Titon Ultimate® Active Vent

for effortless indoor air control

For use in residential dwellings and light commercial applications

Introducing the Titon Ultimate® Active Vent – the ultimate solution for effortless indoor air comfort control.

The Titon Ultimate® Active Vent provides unparalleled comfort and ventilation with its automatic exhaust aperture adjustment, high rotational sensitivity, and responsive low airflow control. Its unique design balances air pressures, preventing impact noise and adverse effects from high wind pressure, ensuring a peaceful indoor environment.



Features & Benefits

- The Titon Ultimate Active Vent maintains the required airflow with increased external wind pressure
- Highly sensitive to pressure changes.
- Ensures indoor air comfort by minimising any chill factor due to high wind pressure
- Provides an Equivalent Area (EA) of 2000mm²
- For use with Titon's High Flow Canopy
- Range of acoustic canopy solutions available
- Can be installed alongside intermittent, decentralised and centralised extract fans
- Easy screw-screw installation
- Designed to work in conjunction with the energy efficient constant flow Titon Ultimate® dMEV
- Manual shut off
- Patented design

Manufactured from

Active Vent – ABS, Acetal & Alum

Canopy – PP & Alum

Recommended screws

3.5mm (No.6) Pan Head or equivalent

Standards

Tested in accordance with BS EN 13141-1:2019 (airflow, air leakage and weather tightness)

Performance

(Full test details available on request)

Equivalent Area (EA) – 2000mm²

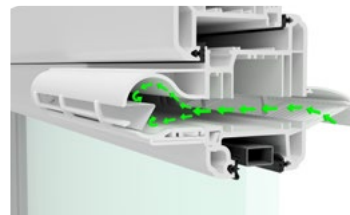

High wind pressure



Medium wind pressure

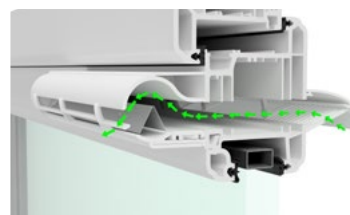

Low wind pressure

Performance

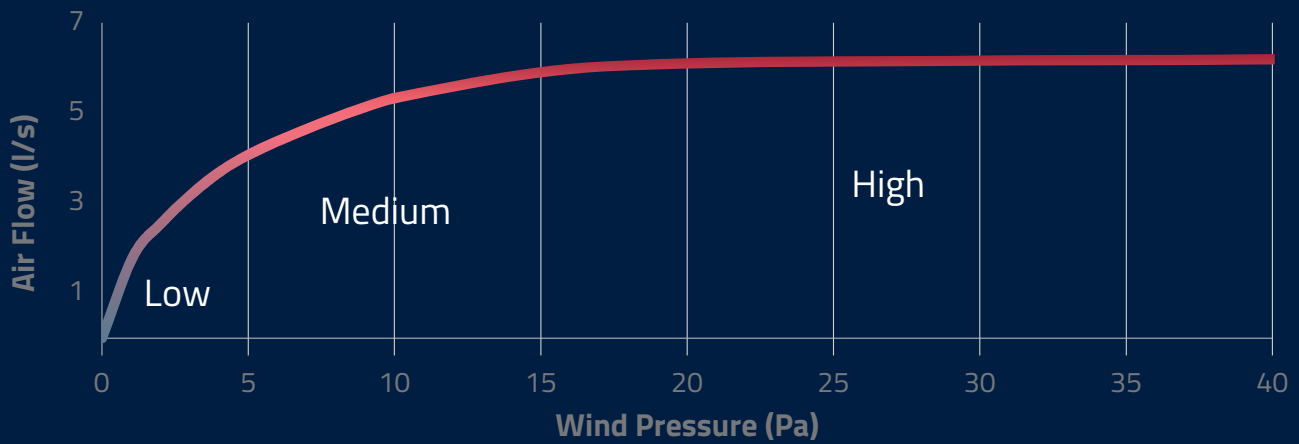

Product Breakdown

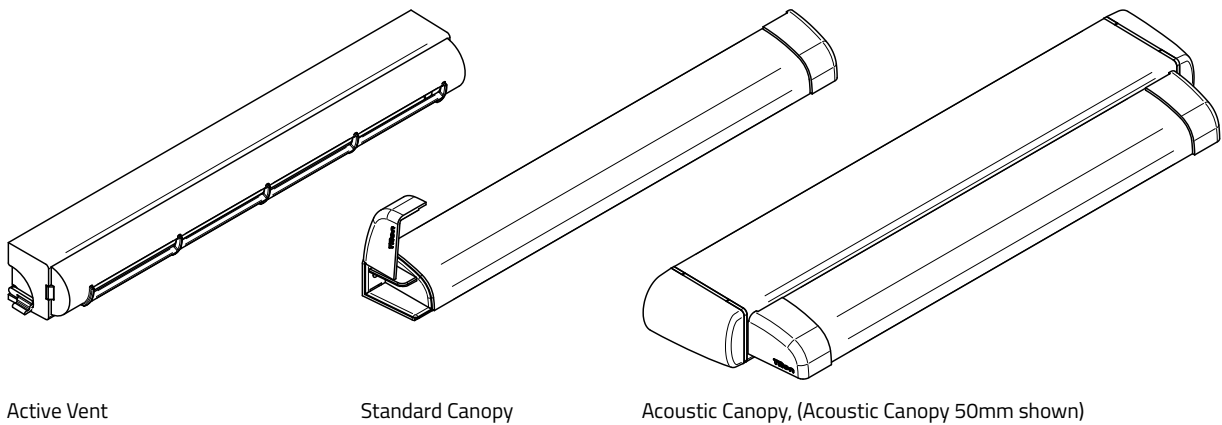

Product Name	Part Number	Length mm	Width mm	Projection mm	Fixing Centres (X) mm	Recommended Fixing Screws
Ultimate Active Vent	TA9521	288	35	43	270	Ø4 (No. 8) Countersunk Head
Standard Canopy	TA6057	305	24	36.5	286.5	Ø3.5 (No. 6) Pan Head
Acoustic Canopy 25mm	TA5252	350.5	35	63.5	322	Ø4 (No. 8) Pan Head
Acoustic Canopy 50mm	TA5254			88.5		
Acoustic Canopy 75mm	TA5256			113.5		

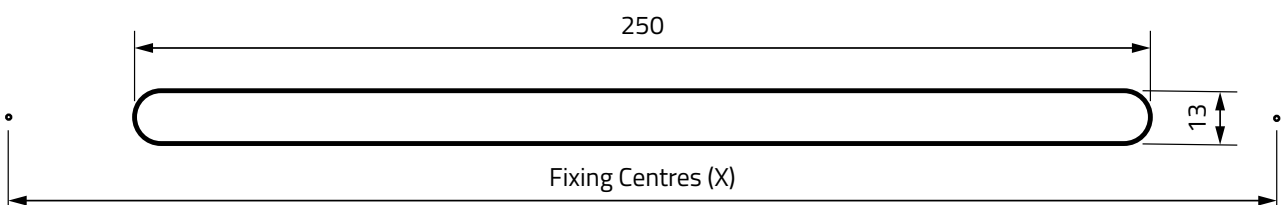

auraSMART® app

Control your HRV unit over WiFi

For use with Titon HRV Q Plus Range

Titon has launched its new auraSMART® app, which enables greater user control of our HRV range of MVHR units. Easy and straightforward to use, the new auraSMART® app is ideal for installers and homeowners alike.

The new auraSMART® app available using Android or iOS mobile devices allows greater flexibility and control. With a user friendly interface, easy monitoring of your whole house ventilation systems is possible. Ideal for commissioning to guide the install process, the new auraSMART® app can cater for it all. Helping you to maintain indoor air quality for a healthy home environment.

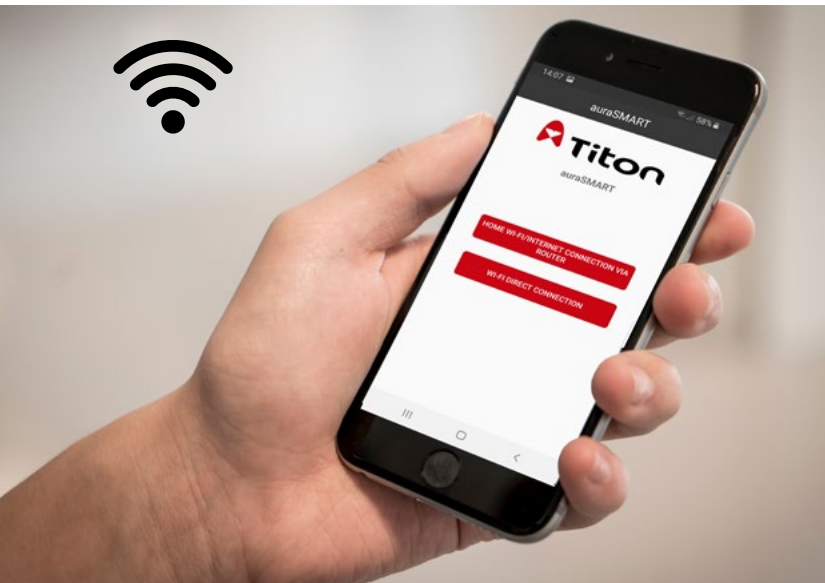

Features & Benefits

- Greater flexibility and control of your MVHR
- Available on android or apple platforms
- Clear and simple interface for ease of use
- Simple and straightforward commissioning
- MVHR status, including service information
- Monitor and control functions
- Set-point adjustments, RH, boost overrun times etc.
- WiFi direct connection for installers (no internet required)
- Full internet connection enables users to check and amend their ventilation whilst away from the home
- Assign different functions to switch inputs on the controller
- Link to multiple HRV units from the same APP
- Compatible with "B" model Titon HRV control systems with WiFi enabled and aura-t™ SMART (WiFi) controller

Description

auraSMART® app is available on google and apple platforms. Compatible with aura-t™ SMART (WiFi) TP736 controller.

auraSMART® app is a multi-language controller where the user can select from the following languages:

- English
- Danish
- Dutch
- French
- German
- Italian
- Spanish
- Polish
- Lithuanian
- Russian
- Ukrainian
- Slovenian
- Hungarian
- Slovakian
- Czech
- Latvian
- Estonian

Internet or Direct WiFi Connection



Fan Speed Control

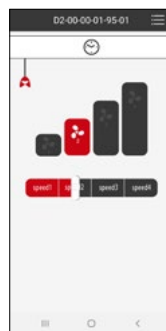

Fan Commissioning

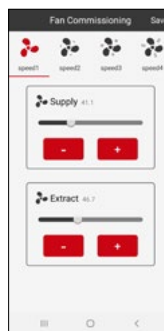

Summer Bypass Control

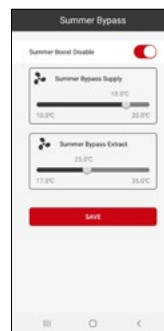

Boost Control



Humidity Threshold Setting



Switch/Control Options

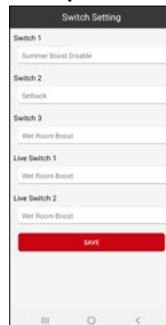

Timer Scheduler

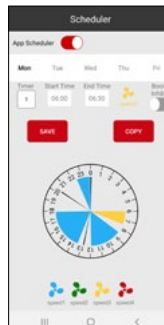

Set Additional Switch Inputs

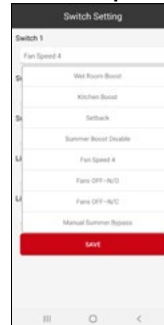

aura-t™ SMART (WiFi)

HRV Q Plus Touch Screen WiFi Programmer panels

For use with Titon HRV Q Plus B Model Range

aura-t™ SMART (WiFi) is a simple yet striking touchscreen controller for programming, commissioning and occupancy control for Titon's range of Mechanical Ventilation Heat Recovery (MVHR) units.

The aura-t™ SMART (WiFi) controller allows straightforward operation of ventilation speeds. Offering WiFi connection via Titon's auraSMART® app available via Android or iOS mobile devices.

Product Number

aura-t™ SMART (WiFi) - TP736

Controls



De-

Features & Benefits

- Simple user friendly interface
- WiFi connection
- Compatible with auraSMART® app
- Compact sleek design
- 4 speed manual control (OFF feature)
- 7 day programmable automatic Speed 1 timer
- Real-time fan commissioning for all speeds
- Filter change alert indicator
- Internal humidity threshold adjustment
- Kitchen & wet room boost overrun time adjustment
- Programmable boost inhibit
- Switch configuration menu
- Time and day display
- Backlight with automatic dimming
- Real-time indication of HRV status and operating mode
- Optional passcode protected commissioning and setup screens
- Summer bypass configuration menu
- 8 hour time out for manual operation
- Fan failure indication
- Fan speed cloning - copy settings from one to another
- Compatible from software version FW0027-0206 onwards circa. June 2016

Specification

Dimensions:	87mm wide x 87mm high x 24mm deep supplied with 3 metre connection cable.
Weight:	185g
Finish:	High gloss finish
Materials:	ABS
Guarantee period:	1 year
Electrical:	12V DC

Drawing and Dimensions

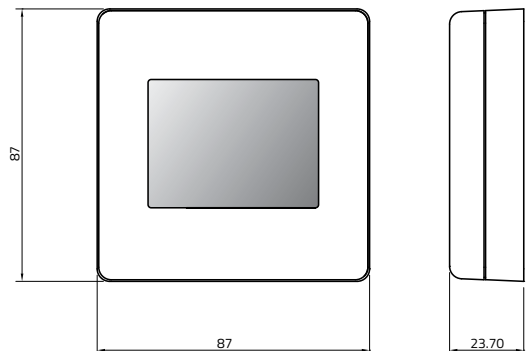

Dimensions in mm

Description

Titon's aura-t™ SMART (WiFi) is for commissioning and monitoring a Titon TP***B HRV Q Plus unit.

aura-t™ SMART (WiFi) provides the following functions:

- Compatible with auraSMART® app
- WiFi connection
- Digital 4 speed switch
- Auto timed speed mode
- 7-day, 4 events per day programmable Speed 1 timer
- Filter change indicator
- Internal MVHR humidity set point adjustment
- Boost inhibit functions linked to timed Speed 1 (avoiding night time boosting via either switch inputs or humidity)

aura-t™ SMART (WiFi) is an icon based rather than language specific controller.

aura-t™ (B)

HRV Q Plus Touch Screen Programmer

For use with Titon HRV Q Plus B Model Range

aura-t™ is a simple yet striking touchscreen controller for programming, commissioning and occupancy control for Titon's range of Mechanical Ventilation Heat Recovery (MVHR) units.

The aura-t™ touch screen controller allows straightforward operation of ventilation speeds. Offering a display that is backlit.

Product Number

aura-t™ - TP536/EU

aura-t™ - TP536/GBR

Controls



aura-t™ provides the following functions:

- Digital 4 speed switch
- Auto timed speed mode (TP536/EU only)
- 7-day, 4 events per day programmable Speed 1 timer (TP536/EU only)
- Filter change indicator
- Internal MVHR humidity set point adjustment
- Boost inhibit functions linked to timed Speed 1 (avoiding night time boosting via either switch inputs or humidity)

aura-t™ is an icon based rather than language specific controller.

Description

Titon's aura-t™ HRV is for commissioning and monitoring a Titon TP***B HRV Q Plus unit.

Features & Benefits

- Simple user friendly interface
- Not compatible with auraSMART® app
- Compact sleek design
- 4 speed manual control (OFF feature TP536/EU only)
- 7 day programmable automatic Speed 1 timer (TP536/EU only)
- Real-time fan commissioning for all speeds
- Filter change alert indicator
- Internal humidity threshold adjustment
- Kitchen & wet room boost overrun time adjustment
- Programmable boost inhibit (TP536/EU only)
- Switch configuration menu
- Time and day display
- Backlight with automatic dimming
- Real-time indication of HRV status and operating mode
- Optional passcode protected commissioning and setup screens
- Summer bypass configuration menu
- 8 hour time out for manual operation (TP536/EU only)
- Fan failure indication
- Manual boost inhibit (TP536/GBR only)
- 1 hour time out for Speeds 1,3 and 4 (TP536/GBR only)

Specification

Dimensions:	87mm wide x 87mm high x 24mm deep supplied with 3 metre connection cable.
Weight:	185g
Finish:	High gloss finish
Materials:	ABS
Guarantee period:	1 year
Electrical:	12V DC

Drawing and Dimensions

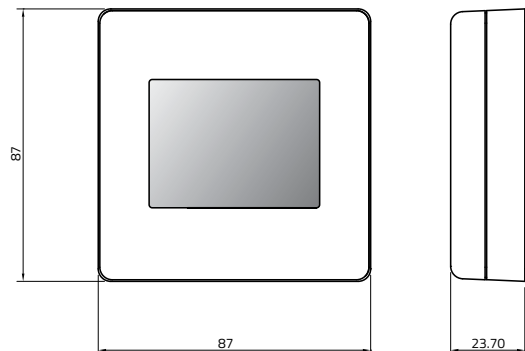

Dimensions in mm

aura-t™ (HMB)

HRV Q Plus Touch Screen Programmer

For use with Titon HRV Q Plus HMB Model Range

aura-t™ is a simple yet striking touchscreen controller for programming, commissioning and occupancy control for Titon's range of Mechanical Ventilation Heat Recovery (MVHR) units.

The aura-t™ touch screen controller allows straightforward operation of ventilation speeds. Offering a display that is backlit, and provides enhanced functionality when connected to a 2019 HMB model.

Product Number

aura-t™ - TP539

Controls



aura-t™ provides the following functions:

- Digital 4 speed switch
- Filter change indicator
- Internal MVHR humidity set point adjustment
- Boost inhibit
- 4 speed settings
- Running hour indicator
- Fan speed cloning
- Switch input set up
- Summer bypass temperature settings

aura-t™ is an icon based rather than language specific controller.

Description

Titon's aura-t™ HRV is for commissioning and monitoring a Titon TP***HMB (2019 models) HRV Q Plus unit.



Features & Benefits

- Simple user friendly interface
- Not compatible with auraSMART® app
- Compact sleek design
- 4 speed manual control
- Fan speed and air temperature display
- Real-time fan commissioning for all speeds
- Filter change alert indicator
- Internal humidity threshold adjustment
- Kitchen & wet room boost overrun time adjustment
- Switch configuration menu
- Backlight with automatic dimming
- Real-time indication of HRV status and operating mode
- Passcode protected commissioning and setup screens
- Summer bypass configuration menu
- Fan failure indication
- Manual boost inhibit
- 1 hour time out for Speeds 1,3 and 4
- Fan speed cloning - copy settings from one to another
- Simple plug connection to MVHR
- Boost alert - if unit is in boost for over 2 hours
- Power saving Eco mode
- Running hours display

Specification

Dimensions:	87mm wide x 87mm high x 24mm deep supplied with 3 metre connection cable with moulded 4 way plug.
Weight:	185g
Finish:	High gloss finish
Materials:	ABS
Guarantee period:	1 year
Electrical:	12V DC

Drawing and Dimensions

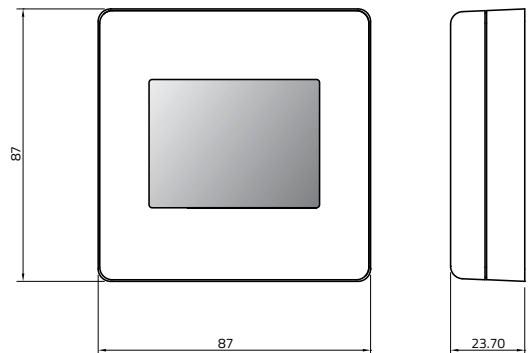

Dimensions in mm

auralite® HRV

HRV Q Plus Basic Indicator

For use with Titon HRV Q Plus Range

auralite® HRV is a low voltage, hard wired status indicator sited remotely from the unit.

Product Number

auralite® HRV - **TP518*** (Compatible with TP***HMB Only)

auralite® HRV - **TP519** (Compatible with TP***B Only)

*Flying lead option only, where aura-t™ is not present.

Description

auralite® HRV is a remote status indicator for use with Titon HRV Q Plus unit.

Indicator



auralite® HRV has six LEDs which display;

Normal - the system is running at continuous speed (normal mode) or the unit is running at setback speed if this light is flashing

Frost - the unit is in automatic frost protection mode.
TP519 if flashing - internal frost protection - indoor temperature low - both fans stop.

Filter - the filters require changing

Boost - the system is running in boost speed:

TP518 - If flashing indicates boost alert (**HMB model only**)

TP519 - If flashing indicates SUMMERboost®/speed 4 (**B model only**)

Summer - the unit is in summer bypass mode

Fault - there is a fault with the system and the installer should be contacted.

Normal/Boost - alternating indicates demand control from proportional sensors (only applicable with **TP519**)

auralite® HRV is to be used with Titon's HRV units. For compatibility please contact us on +44 (0)1206 814879 or ventsales@titon.co.uk.

Features & Benefits

- Meets guidelines for occupant accessibility
- Increase occupant awareness of system operation
- Can be sited remotely from unit in an easy to access location
- Discreet design
- Fits a standard UK pattress box
- Compatible with Titon HRV units

Standards

Meets guidelines for occupant accessibility as set out in NHBC Standards 2022 - Section 8.3.6:

MVHR systems should include visual indicators showing maintenance and serving requirements, and mode of operation. These should be visible from within the insulated envelope, not obscured from view, and be simple to use.

Specification

Dimensions: 90mm wide x 90mm high x 12mm deep

Weight: 50g

Finish: High gloss finish

Materials: Polycarbonate

Guarantee period: 1 year

Electrical: 12V DC

Installation: Suitable for mounting on a standard UK recessed pattress box. Supplied with screws.

Drawing and Dimensions

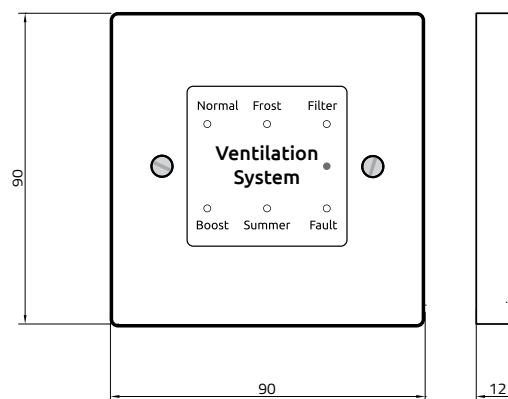

Dimensions in mm

auralite® CME

CME Q Plus Basic Indicator

For use with Titon CME Q Plus Range

auralite® CME is a low voltage, hard wired status indicator sited remotely from the unit.

Description

auralite® CME is a remote status indicator for use with Titon CME Q Plus range of units.

Product Number

auralite® CME- **TP517** (Compatible with TP***CH Only)

Indicator



auralite® CME has six LEDs which display;

Setback - Unit is running at Setback Speed.

Normal - Unit is running at Normal Speed.

Boost - Unit is running at Boost Speed.

Humidity Control - Humidity sensor is controlling unit's fan speed.

Boost Overrun - The Boost Overrun Timer is active.

Fault - Unit has a fault - Contact the installer.

auralite® CME is to be used with Titon's CME units with product code ending "CH". For compatibility please contact us on +44 (0)1206 814879 or ventsales@titon.co.uk.

Features & Benefits

- Meets guidelines for occupant accessibility
- Increase occupant awareness of system operation
- Can be sited remotely from unit in an easy to access location
- Discreet design
- Fits a standard UK pattress box
- Compatible with Titon CME units

Specification

Dimensions: 90mm wide x 90mm high x 12mm deep

Weight: 50g

Finish: High gloss finish

Materials: Polycarbonate

Guarantee period: 1 year

Electrical: 12V DC

Installation: Suitable for mounting on a standard UK recessed pattress box. Supplied with screws.

Drawing and Dimensions

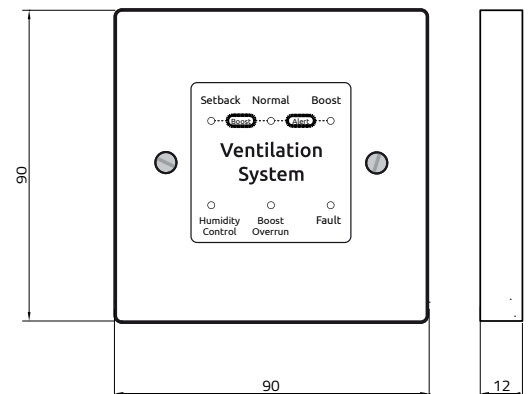

Dimensions in mm

Touch Button Timer

Controls, Switches and Sensors

For use with Titon HRV Q Plus Range

The Touch Button Timer delay switch is designed to provide timed control of ventilation loads. Using push button, touch (light press required), the user can switch on a load for a preset time period and have the load turn off automatically after the time period has elapsed.

Multiple timing ranges come as standard to allow the time out period to be set accurately. Time setting is achieved using switches and a thumbwheel at the rear of the unit.

Product Number

Touch Button Timer - **TP581**



Wiring Diagram

Wire TP581 as in the diagram below. Connection to the TRIG terminal is optional.

Applying a live to the trigger terminal will start the timer running. A momentary switch can be used, for example, in corridor lighting applications. A permanent input can be used, for example, in pump overrun applications.

To switch from more than one position simply wire two or more units in parallel to achieve two way and intermediate switching, or use the trigger terminal with a slave switch.

TP581 comes with a voltage free output contact with the following connections: common (COM); normally open (NO) and normally closed (NC).

When installing touch switches do not fix to a vibrating or uneven surface.

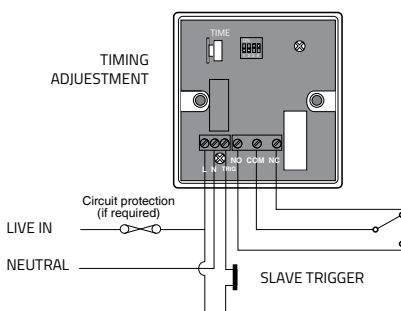

Features & Benefits

- Pushing the button activates the circuit and starts the timing period (this is easily adjustable and is set at installation to any time between 1 second and 2 hours). Complete with voltage free contact.
- Adjustable timer
- Switches any type of load

Specification

10 Amp resistive load
10 Amp incandescent lighting
6 Amp fluorescent lighting
3 Amp compact fluorescent lighting
3 Amp low energy lighting
3 Amp low voltage lighting (switch primary of transformer)
Fluorescent lighting (max 6 fittings recommended)
For fluorescent lighting total power factor correction capacitance must not exceed 40µF.
3 Amp fans and ventilation equipment
Switch SON lighting loads via a contactor

Supply Voltage 220-240 Volts AC 50 Hz

Time Out Period Adjustable 1 second to 2 hours in ranges

Fixing Method **Surface fixing** 25mm deep plastic surface mount moulded box
Flush fixing 25mm steel wall box or 32mm deep cavity wall box.

Terminal Capacity 1.5mm²

Material Flame retardant ABS

Type Class 2

Temperature -10°C to 35°C

Conformity EMC-2004/108/EC
LVD-2006/95/EC

Drawing and Dimensions

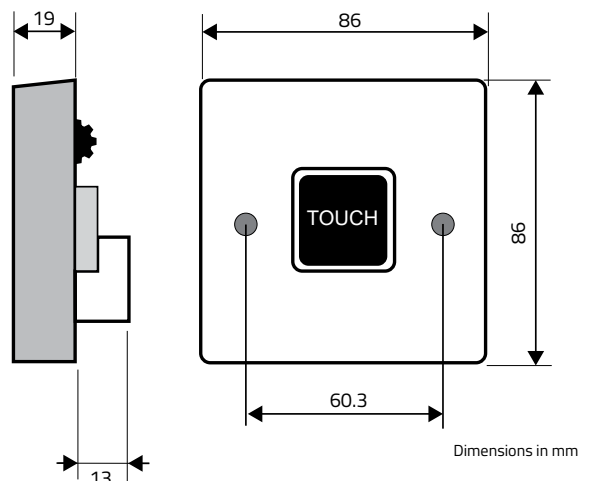

PIR | Movement - Sensor

Controls, Switches and Sensors

For use with Titon HRV Q Plus Range

The PIR detector switch is designed to provide automatic control of ventilation loads. They detect movement using a PIR sensor and turn the load on. When an area is no longer occupied the unit will switch off after an adjustable time out period.

When the unit is first powered up the PIR sensor will always detect immediately regardless of whether the room is occupied. A selectable power up delay allows the installer to choose whether the load comes on immediately when the unit is powered up or is kept off for a small time (about 40 seconds) to allow the sensor to settle.

Product Code

PIR Movement Sensor - TP580

PIR



Wiring Diagram

The PIR comes with a voltage free output contact with the following connections: common (COM); normally open (NO) and normally closed (NC).

The detector should be sited so that the occupants of the room fall inside the detection pattern shown overleaf, at a recommended height of 1.2m to 1.5m for wall sensors.

Note that the higher the sensor is installed the shorter the detection range will be.

- Avoid direct sunlight entering the sensor
- Do not site within 1m of forced air heating or ventilation.
- Do not site within 1m of any lighting.
- Do not fix to a vibrating surface.

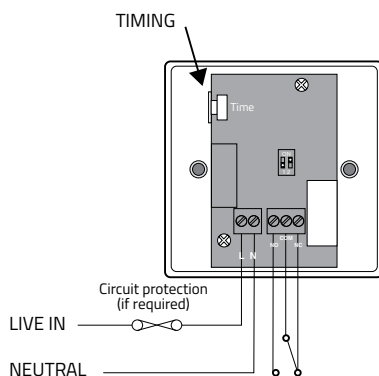

Features & Benefits

- Movement sensor auto on, auto off
- Lux level sensing
- This version is a voltage free contact option and suitable for use with BMS and control applications.

Specification

10 Amp resistive load
10 Amp incandescent lighting
6 Amp fluorescent lighting
3 Amp compact fluorescent lighting
3 Amp low energy lighting
3 Amp low voltage lighting (switch primary of transformer)
Fluorescent lighting (max 6 fittings recommended)
For fluorescent lighting total power factor correction capacitance must not exceed 40µF.
3 Amp fans and ventilation equipment
Switch SON lighting loads via a contactor

Supply Voltage	220-240 Volts AC 50 Hz
Time Out Period	Adjustable 10 seconds to 60 minutes in two ranges
Light Level	Optional adjustment by thumbwheel light to dark.
Fixing Method	Surface fixing 25mm deep plastic surface mount moulded box. Flush fixing 25mm steel wall box or 32mm deep cavity wall box.
Terminal Capacity Material	1.5mm ² Flame retardant ABS
Type	Class 2
Temperature Conformity	-10°C to 35°C EMC-2004/108/EC LVD-2006/95/EC

Drawing and Dimensions

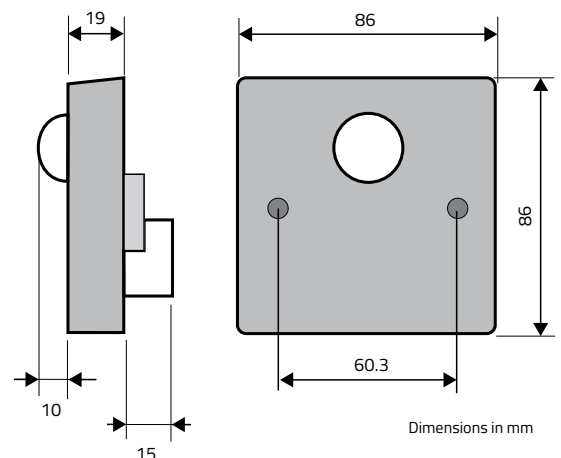

PIR | Presence/Absence

Detector and handset

For use with Titon HRV Q Plus Range

The TP583 ceiling mounted (passive infrared) presence detector provides automatic timed control of ventilation with optional manual control.

The output channel comprises a mains voltage relay capable of simple on/off switching. This unit provides an isolated voltage free contact output.

Functioning as a presence detector, the unit can boost when a room is occupied and off when the room is empty.

Product Number

Ceiling PIR presence/absence detector volt free contact - **TP583**

UHS5 Programming IR handset - **TP584**

Features & Benefits

- **PIR Sensor** - Detects movement within the unit's detection range, allowing load control in response to changes in occupancy.
- **IR Receiver** - Receives control and programming commands from an IR (infrared) handset.
- **Light Level Sensor** - Measures the overall light level in the detection area
- **Status LEDs** - The LED flashes Red to indicate the following; **Power Input & Switch Input Connector. Used to connect mains power to the unit and to connect a switch to manually override the lights on or off.**
- **Output Connector** - Connection to a switched load.

Specification (Load)

Weight 0.15kg
Supply Voltage 230VAC +/- 10%
Frequency 50Hz

Maximum Load:

Normally open contact
 6 Amp fluorescent lighting and resistive
 3 Amp compact fluorescent lighting
 3 Amp low energy lighting
 3 Amp low voltage lighting (switch primary of transformer)
 Fluorescent lighting (max 6 fittings recommended)
 Fluorescent lighting (max 6 fittings recommended)
 For fluorescent lighting total power factor correction capacitance must not exceed 40µF.
 3 Amp fans and ventilation equipment
 Switch SON lighting loads via a contactor
 Minimum load 100mA
 Normally closed contact
 2 Amp maximum
 Minimum load 100mA

Time Period 1-30 minutes
Power consumption On 286mW, Off 728mW
Terminal Capacity 2.5mm²
Temperature -10°C to 35°C
Humidity 5 to 95% non-condensing
Material (casing) Flame retardant ABS and PC/ABS
Type Class 2
IP rating IP40
Compliance EMC-2004/108/EC LVD-2006/95/EC

Wiring Diagram

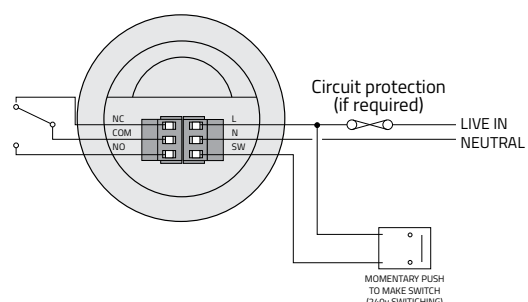

PIR



Drawing and Dimensions

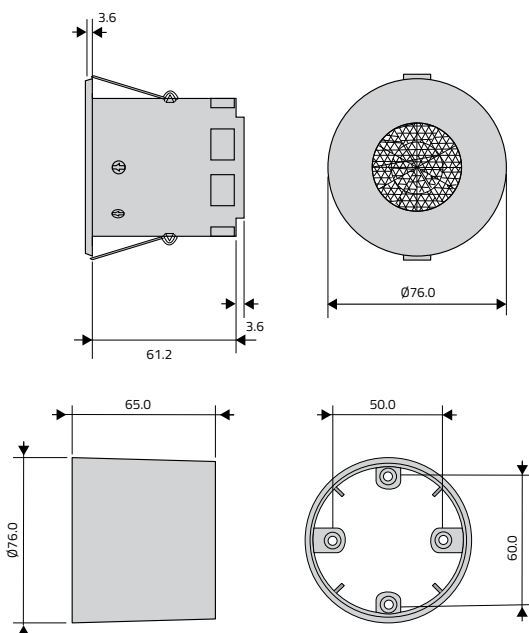

Room Sensor | VOC

Controls, Switches and Sensors

For use with Titon HRV Q Plus Range

The Room VOC sensor is used to continuously monitor indoor air quality and for effective control of ventilation (HVAC) systems according to current air quality.

The sensor monitors the concentration of VOC - Volatile Organic Compounds in air. Built-in advanced VOC sensor is sensitive to volatile organic compounds typically contained in the exhausted air - gaseous metabolic products of human bodies and other gaseous pollutants such as formaldehyde, disinfectant vapours, cooking vapours, fumes from paints, varnishes, adhesives, detergents, cigarette smoke etc. that the CO₂ sensor does not detect.

There is the possibility to select eCO₂ (estimated CO₂) measurement mode. In this mode the sensor uses special algorithm to estimate CO₂ concentration based on the assumption that the TVOC produced by human metabolism is proportional to the exhaled CO₂. The analogue voltage output of the sensor is adjusted as equivalent to a standard CO₂ sensor in range of 400–2000 ppm of estimated CO₂.



trigger level of output relay can be set by a rotary element. Ventilation and heat recovery units can be directly controlled based on the output signal of sensor in the most efficient way.

Current air quality can be easily checked by three LED indicators.

Product Number

Room VOC Sensor - **TP540**

Drawing and Dimensions

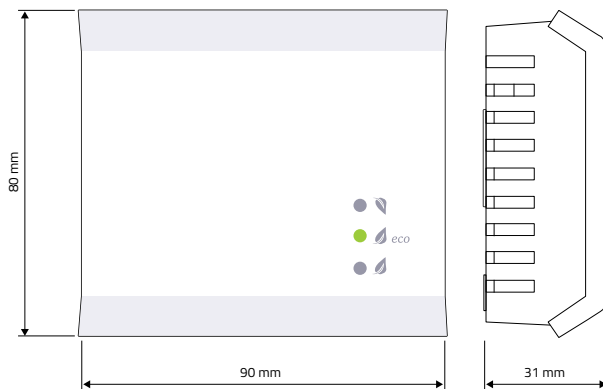

Dimensions in mm

Features & Benefits

- Monitors VOC
- TVOC output in conformance with EPA and UBA standards
- Detects the true cause of ventilation demands
- Three-level LED indication
- No disturbance at night – automatic turn off of LED indication
- Analogue voltage output 0-10V
- Three selectable TVOC ranges
- eCO₂ output compatible with CO₂ standard
- Output relay C/NO
- Maintenance free during operation
- Long life and stability
- Wide range of supply voltage
- Colour: Front – White, Base – Grey

Specification

Parameter	Value	Unit
Supply voltage range	12 – 35	V DC
Consumption	12 – 24	V AC
Measuring range TVOC ¹⁾	max 1.5	W
	0 – 1000	µg/m ³
	0 – 3000	
Measuring range eCO ₂ ¹⁾²⁾	400 – 2000	ppm
Relay - hysteresis	5% from selected range	
Voltage output ³⁾	0 – 10	V DC
Max. switching voltage	250/30	V AC / V DC
Max. switching current	5-5	A AC / A DC
Working humidity non condensing	10 – 95 %	RH
Working temperature	0 to +50	°C
Storage temperature	-20 to +60	
Expected lifetime	10	years
Ingress protection	IP20	
Dimensions	90x80x31	mm

¹⁾ Output type and range can be set with jumpers. Factory setting range is TVOC 0 - 3000 µg/m³.

²⁾ Calculated estimated CO₂ concentration (estimated CO₂ - eCO₂).

³⁾ Minimum achievable output value corresponds to minimum value of the selected measuring range.

Room Sensor | CO₂

Controls, Switches and Sensors

For use with Titon HRV Q Plus Range

The Room Sensor CO₂ is used to monitor air quality inside a dwelling and effectively control ventilation system according to current levels of internal air quality.

The sensor measures concentration of carbon dioxide (CO₂) in air. The measuring of CO₂ is based on the principle of infrared radiation attenuation dependence on the CO₂ concentration in the air (NDIR).

Built-in auto-calibration function ensures very good long term stability. The sensor has one analog output for the actual concentration of CO₂.

Heat recovery units can be directly controlled based on the output signal of the sensor in very efficient way.

The trigger level of CO₂ concentration output relay can be set by a rotary element. Current air quality can be easily checked by three LED indicators. When ambient light is dimmed, the indicators turn off automatically to not disturb you when falling asleep.



Product Number

Room CO₂ Sensor - **TP541**

Drawing and Dimensions

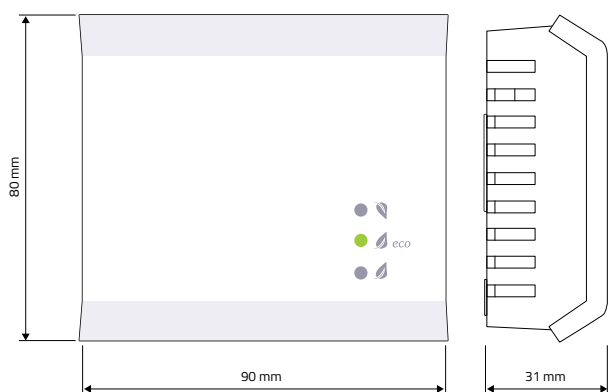

Dimensions in mm

Features & Benefits

- Measures CO₂, optical principle NDIR
- LED indication with automatic turn off according to ambient light (at night)
- Analog voltage output 0-10V
- Output relay NO/C
- Maintenance or calibration not required during operation
- Long-term stability
- Expected lifetime >10 years
- Colour: Front – White, Base – Grey

Specification

Parameter	Value	Unit
Supply voltage range	12 – 35	V DC
	12 – 24	V AC
Consumption	max 1.5	W
CO ₂ measuring range ¹⁾	400 – 1000	ppm
	400 – 2000	
	400 – 5000	
CO ₂ accuracy ²⁾		
- for ranges 400 – 1000 and 400 – 2000 ppm	± 40 ppm + ± 4 % of reading	
- for range 400 – 5000 ppm	± 60 ppm + ± 4 % of reading	
CO ₂ relay - hysteresis	5 % from range (100ppm/250ppm)	
CO ₂ rate rise	max 1	min
CO ₂ step response	(90 %) 80	s
Voltage output ³⁾	0 – 10	V DC
Max. switching voltage	250/30	V AC / V DC
Max. switching current	5/5	A AC / A DC
Working humidity non condensing	0 – 95 %	RH
Working temperature	0 to +50	°C
Storage temperature	-20 to +60	°C
Expected lifetime	10 years	
Ingress protection	IP20	
Dimensions	90x80x31	mm

¹⁾ Measuring range can be chosen by jumper setting.

²⁾ At 15 – 35 °C, 0-80% RH.

³⁾ Minimum achievable output value corresponds to minimum value of the measuring range.

Room Sensor | Humidity

Controls, Switches and Sensors

For use with Titon HRV Q Plus Range

Room humidity sensor is used to monitor the air quality inside buildings and effectively control ventilation (HVAC) systems according to current levels of air pollution.

The sensor measures the relative humidity (RH) in air. It is suitable for living rooms, bathrooms, warehouses, ateliers etc.

Measurement of the relative humidity is based on the principle of capacitive polymer sensor.

The sensor has one analog output for the actual concentration of RH. The trigger level of RH output relay can be set by a rotary element.

Ventilation, air conditioning and heat recovery units can be directly controlled based on the output signal of the sensor in very efficient way.

Current air quality can be easily checked by three LED indicators. When ambient light is dimmed, the indicators turn off automatically to not disturb you at night.

Features & Benefits

- Measures relative humidity in air
- LED indication with automatic turn off according to ambient light (at night)
- Analog voltage output 0-10V
- Output relay NO/C
- Maintenance or calibration not required during operation
- Long life and stability
- Colour: Front – White, Base – Grey

Specification

Parameter	Value	Unit
Supply voltage range	12 – 35	V DC
	12 – 24	V AC
Consumption	max 1.5	W
RH measuring range	0 – 100 %	RH
RH accuracy 20 – 80 %	± 3 %	
RH accuracy 0 – 100 %	± 6 %	
RH switching hysteresis	5 %	
Voltage output	0 – 10	V DC
Max. switching voltage	250/30	V AC / V DC
Max. switching current	5/5	A AC / A DC
Working humidity non condensing	0 – 90 %	RH
Working temperature	0 to +50	°C
Storage temperature	-20 to +60	
Expected lifetime	min. 10	years
Ingress protection	IP20	
Dimensions	90x80x31	mm



Product Number

Room Humidity Sensor - **TP542**

Drawing and Dimensions

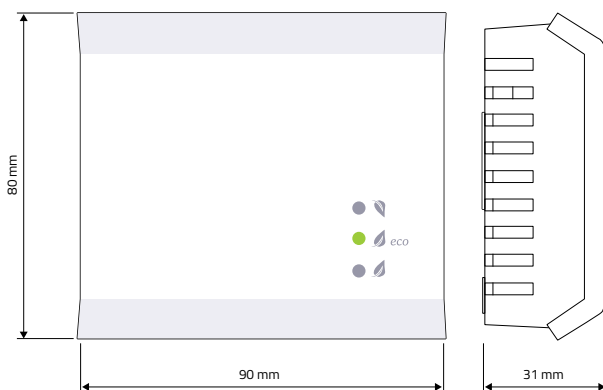

Dimensions in mm

¹⁾ Output type and range can be set with jumpers. Factory setting range is TVOC 0 - 3000 µg/m³.

²⁾ Calculated estimated CO₂ concentration (estimated CO₂ - eCO₂).

³⁾ Minimum achievable output value corresponds to minimum value of the selected measuring range.

Switches

These products are for use with MVHR or CME units, depending on ventilation system design specification.



EHC2 Humidistat External Adjustment (TP501)

Activates Boost function on all HRV and CME units (volt free)



Boost Switch (latching) (TP502)

Activates Boost function on all HRV and CME units



Boost Switch (momentary) (TP503)

Activates Boost (timer overrun) function on Q Plus units only



Summer Mode Switch (latching) (TP506)

Manual operation of Summer Mode on HRV A suffix units without Summer Bypass. Can be used on aurastat® with summer mode.



Boost Ceiling Switch (momentary) (TP507)

Activate the timer overrun on Q Plus units only



Room Thermostat (TP509)

Automatic operation of Summer Mode on HRV A suffix units only. Can be used on aurastat® with summer mode.



SUMMERboost® Switch (TP522)

Disables SUMMERboost® on HRV HMB suffix units only. Can be used on aurastat® and auramode®.



Multifunction Relay (TP505)

Enables multiple switching configurations and mains voltage switching for Q Plus units



3 Speed Switch (TP508)

A 3 position rotary switch to change between setback, continuous or boost running speeds.

Sonair 3

Acoustic (sound attenuating) filtered air supply units

For use fitted through walls

Sonair 3 provides mechanical input ventilation when switched on, when switched off provides background trickle ventilation which includes a controllable shutter.

It is designed with sound attenuating features to reduce noise transferring from outside to inside the home

Sonair 3 is a wall mounted input fan featuring a detachable remote control with an LED speed indicator.

- Sonair 3 ventilates and filters the air
- Independently tested for acoustic performance
- Exceptional sound attenuation (up to 58dB)
- Air cleaning
- Low energy

Sonair 3



Features & Benefits

- Meets guidelines for occupant accessibility
- Increase occupant awareness of system operation
- Discreet design
- power lead is 1.8m long and fitted with a 3 pin plug
- Supplied with a flexible 1.8m long cable with a 13 amp 3 pin plug fitted with a 3 amp fuse

Performance

Approximate input airflow rate (m³/h) – 20-150m³/h

Acoustic Dn,e,w (*/.) – Dn,e,w (C;Ctr) 58(-1;-2)dB*

Tested to the 'Noise Insulation Regulations'

Background ventilation rate of 2400EA when the unit is switched off, recirculation flap closed and with the shutter open

*Sound insulating tube D100 required

Product	Product Code
Sonair 3 including G4/ISO Coarse 60%	352004
Sonair 3 Filter G4/ISO Coarse 60%	535083
Sonair 3 Sound Insulating Tube D100	110361
100mm dia (non-sound insulating) duct 350mm long	8960097
White external grille	8960105
Brown external grille	8960102
Beige external grille	8960103

All items supplied separately

Control

The Sonair 3's portable remote control lets you control the amount of freshly supplied outdoor air. The Sonair 3 has 10 ventilation settings.

Installation

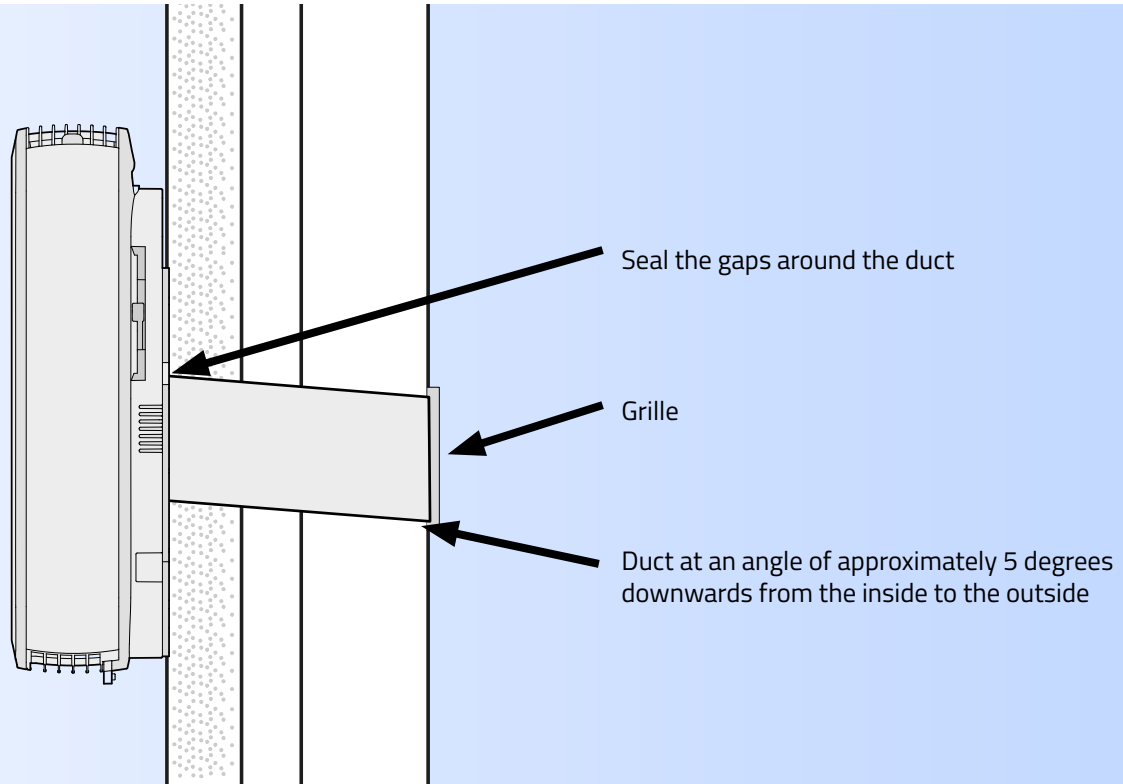

Acoustics

As population density increases, acoustics are becoming an increasingly important factor. Consequently, there is a greater need for sound-attenuating ventilators. Standard or acoustic trickle ventilators cannot provide the necessary attenuation levels, so more sophisticated solutions are required. The Sonair 3 meets these requirements by achieving acceptable noise-reducing levels.

Sound Production

Sound pressure level, LpA; 10 m² according to ISO 3741.

Speed Setting	Approximate Capacity	Sonair 3
		G4/ISO Coarse 60%
1	20m ³ /h	<11.3
2	30m ³ /h	<11.8
3	40m ³ /h	<15.3
4	50m ³ /h	20.8
5	60m ³ /h	24.8
6	70m ³ /h	29.3
7	85m ³ /h	33.8
8	105m ³ /h	39.3
9	125m ³ /h	43.8
10	150m ³ /h	49
Sound Attenuation according to ISO 10140-2 and BS EN ISO 717-1**		
	Dn,e,w (C;Ctr)	58(-1;-2)dB*

*Sound insulating tube D100 required

**Independently tested by the BRE to requirements of noise insulation regulation

Dimensions

445 (H) x 340 (W) x 134 (D)

Housing

Plastic ABS white RAL 9003

Voltage

220-240V/50 Hz

Energy Consumption

0.5W at standby to 22.7W at max speed (150m³/h)

Ventilation Capacity

Max is 4.17l/s (150m³/h) with ISO Coarse 60% filter

Duct

Ø100 mm (standard)

Warranty

2 years

More information

www.titon.com or 01206 814879

Positive Input Ventilation (PIV)

PIV L & PIV L3

For use in domestic dwellings

Positive Input Ventilation or PIV is a concept that delivers fresh filtered air into a home at a continuous rate, which results in reducing condensation, mould and indoor pollution.

Available in two types for the new build market, PIV L (up to 2 floors) or PIV L3 which includes a fire diffuser and a remote control (up to 3 floors). Titon's range of PIV units will create a healthy environment within any dwelling and help combat internal air quality issues.

PIV protects you against

Mould - spores account for a significant amount of household dust.

Dust Mites - you share your bed with thousands of them!

Smoke - 5-10% of all lung cancer is linked directly to passive smoking.

Radon - studies have shown a link to exposure increases the risk of lung cancer.

Volatile organic compounds (VOCs) - can lead to irritation and headaches as well as risk of neurotoxic effects.

Features & Benefits

- Ultra low watt DC motor technology
- Sealed for life ball bearings
- Suitable for loft applications only
- Integral Hours Run Meter (as standard)
- Integral intelligent comfort heater (as standard)
- Remote control boost facility as standard on PIV L3
- Provides all year round quality filtered air
- Reduces/eliminates surface condensation
- Quiet operation
- Removes musty odours
- Enhances heat distribution
- Takes advantage of the benefits of solar gain in the loft space
- Benefits asthma sufferers by reducing dust mites and mould spores
- Reduces Radon levels



Product Codes

TP230 - Titon PIV L (up to 2 floors).

TP231 - Titon PIV L3 (up to 3 floors) with fire rated diffuser and remote control.

Guarantee period: 5 years

Applications

Situated in a loft space, the unit delivers air to the central hallway or landing via a diffuser to maximise efficiency of airflow and aid in heat recover from ceiling level. This provides displacement ventilation in order to improve air quality and resolve condensation related problems.

Accreditations

This product is in conformity with the European Low Voltage Directive 2014/35/EU and the EMC Directive 2014/30/EU including amendments. Full compliance with the relevant parts of the standards listed below supports the conformity of the designated product with the provisions of the above mentioned EC Directives.

EN 60335-1:2012 + AC:2014, EN 60335-2-80:2003 + A1:2004 + A2:2009, EN 61000-6-1:2007, EN 61000-6-3:2007 + A1:2011, EN 62233:2008, EN 62311:2008

Specification

Construction: ABS plastic to contain at least 50% recycled material.

Motor: Incorporates the Ultra Low Watt DC motor technology with sealed for life ball bearings designed to operate continuously at a pre-set 'background' rate.

Fan: 140 x 220mm centre mounted forward curved centrifugal fan.

Filter: Is a synthetic fibre based filter mat to ISO Coarse 60% (G4) standard in accordance with EN779 standard ratings, conforming to all European Union and US fire classification standards (e.g. DIN 53438-F1 and UL900-class 2) and be self-extinguishing.

Servicing/Maintenance

Achieved by exchanging filters and consumable items. There should be no requirement for any maintenance within the five year period.

Accessories:

Integral 'Intelligent Low Temperature' Comfort Heater

Powered by a single supply and capable of holding incoming air temperatures accurately – around 10°C. The integral heater element is manufactured in a solid tubular sheath material and not in open wire format.

Intelligent Remote Control (L3 unit only)

A remote control incorporating five mode settings: small, medium, high, boost and auto is available. Auto-mode enables or disables the heater.

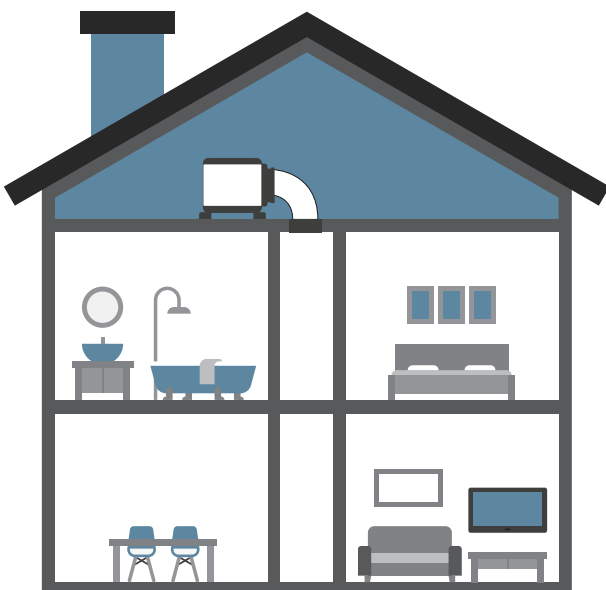

TP230 - Titon PIV L (up to 2 floors)



TP231 - Titon PIV L3 (up to 3 floors) with fire diffuser and remote control

Performance Data

PIV L - (TP230)

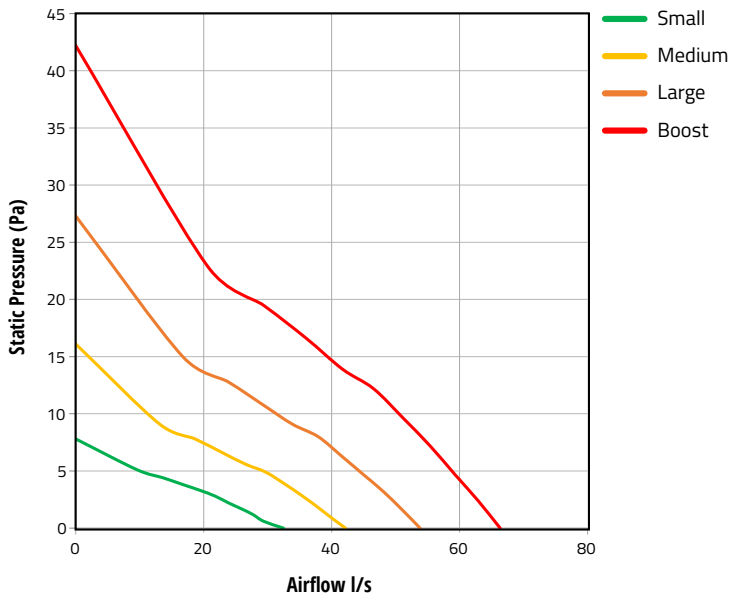

PIV L3 - (TP231)

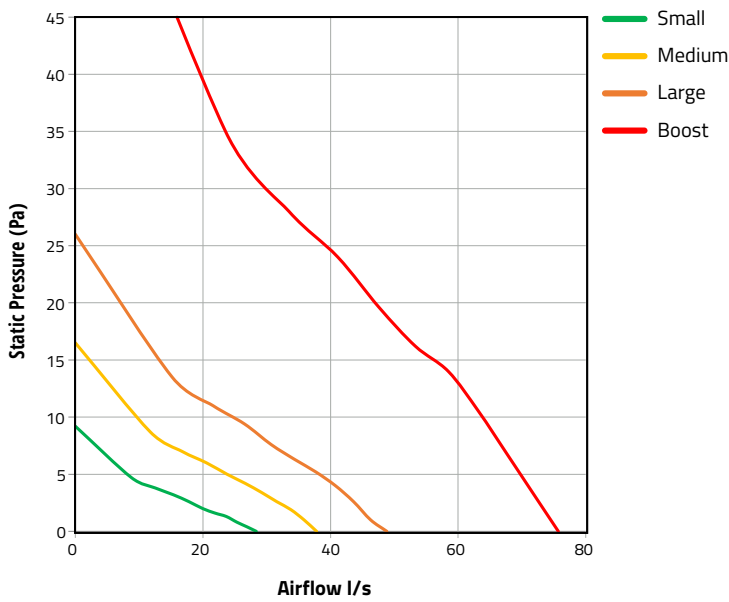

Performance curve results are based on the unit running below 19°C and exclude accessories.

Power and Sound Levels

Product	Incoming Air Temp. (°C)	Fan Speed Setting	Airflow (l/s)	Power Usage (W)	Specific Fan Power (SFP)	Outlet Noise OdB(A) @3m
PIV L (TP230)	<19	Small	21	4	0.17	<15
		Medium	29	4	0.15	<15
		Large	38	6	0.16	<15
		Boost	49	9	0.19	15
PIV L3 (TP231)	<19	Small	20	3	0.13	<15
		Medium	27	3	0.13	<15
		Large	34	5	0.14	<15
		Boost	53	13	0.25	15

Please note that the power figures represent normal running and do not include the heater.

Drawing & Dimensions

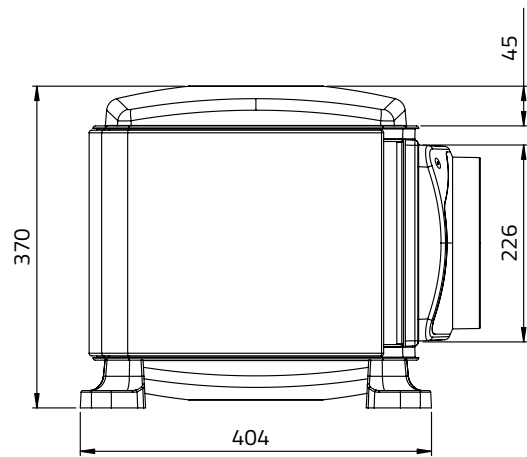
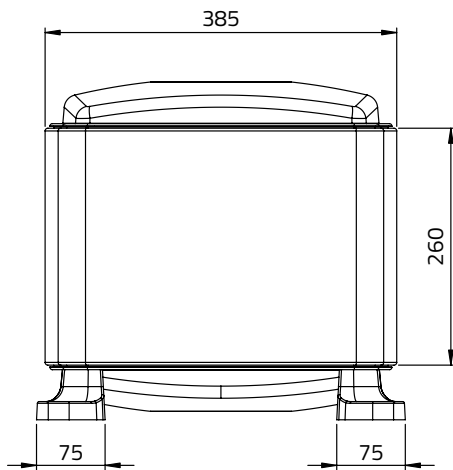
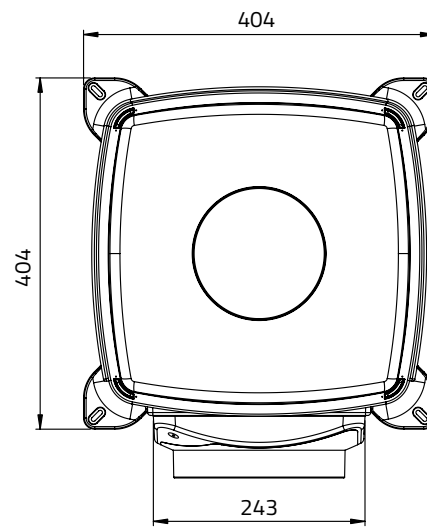
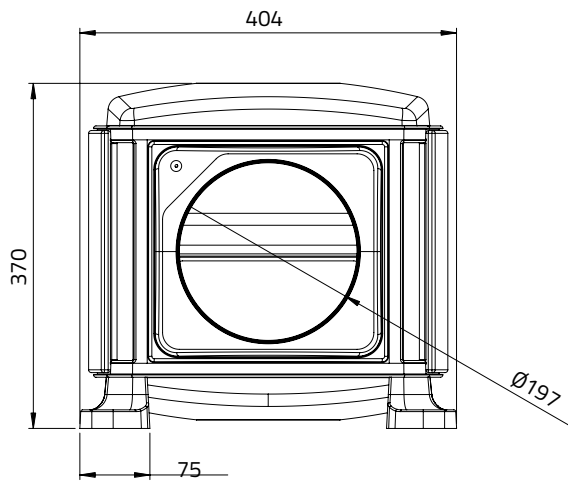

Weight 8kg. Dimensions in mm.

Purge Ventilation Unit

Easy to install ventilation solution

For use in residential dwellings

Titon's Purge ventilation unit has been designed to satisfy the Building Regulations Part F 2010 (2021 edition) requirement for purging as set out in *Appendix B. It allows the rapid removal of stale, odorous and poor quality air from the dwelling allowing a healthier more comfortable environment to be reinstated.

Our Purge unit can be used in an independent purge system in its own right or integrated into our own HRV Q Plus MVHR system to provide additional dedicated purge ventilation.

Purge ventilation can also be used to improve thermal comfort.

*Manually controlled intermittent ventilation of rooms or spaces at a relatively high rate to rapidly dilute high concentrations of pollutants and/or water vapour from occasional activities, equivalent to 4 air changes an hour.

Features & Benefits

- Low Profile
- High efficiency EC fan
- 100% variable speed control for commissioning set point
- 90° configurable option
- Accepts configurations of 220x90mm rectangular ducting and Ø150mm or 220x90mm with adaptor for 90° option
- For use in rooms up to 45m²
- In line configurable option
- Simple 1 setting setup
- Light weight for easy handling
- Easy and quick to install
- Low sound levels
- IPX2 water resistant

Purge

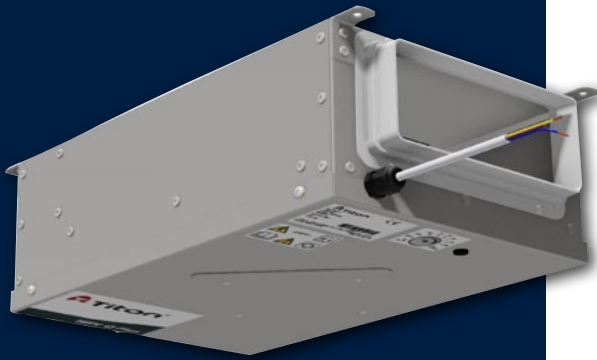

Ceiling cover kit available



Powered Damper Actuator

Product Codes

- TP625 - Purge Unit
- TP629 - Ø150 Back Draft Damper
- TP630 - Powered Damper Actuator
- TP631 - Ceiling Cover Kit (Ø150 only)
- TP502 - Boost Switch (latching)

Standards

EU RoHS Directive Compliant.

Conforms to requirements of EC council Directives relating to electromagnetic Compatibility and Electrical Safety:
 2006/95/EC (LVD), 2004/108/EC (EMC)
 EN 60335-1:2002/A2:2006, EN 60335-2- 80:2003/A1:2004.
 CE and UKCA marked.

Specification

Dimensions:

510mm long x 300mm Wide x 150mm Deep

Weight: 7.2Kg

Finish: Natural Zintec

Materials: Zintec sheet steel casing

Guarantee Period: 2 Years

Electrical: 230V - 50/60Hz, 3A fuse

Maintenance: Service subject to local environment - see product manual.

Performance

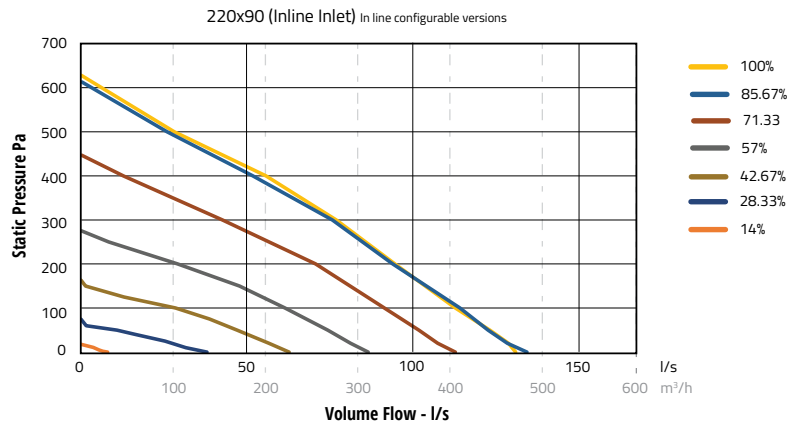
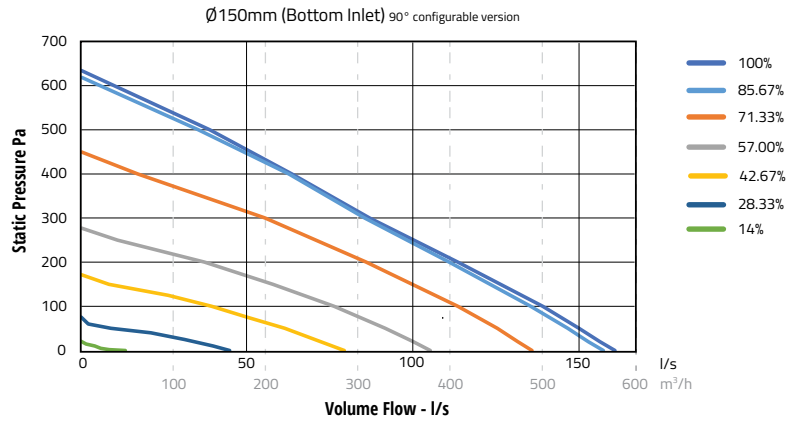

Drawing and Dimensions

Purge Ventilation Unit

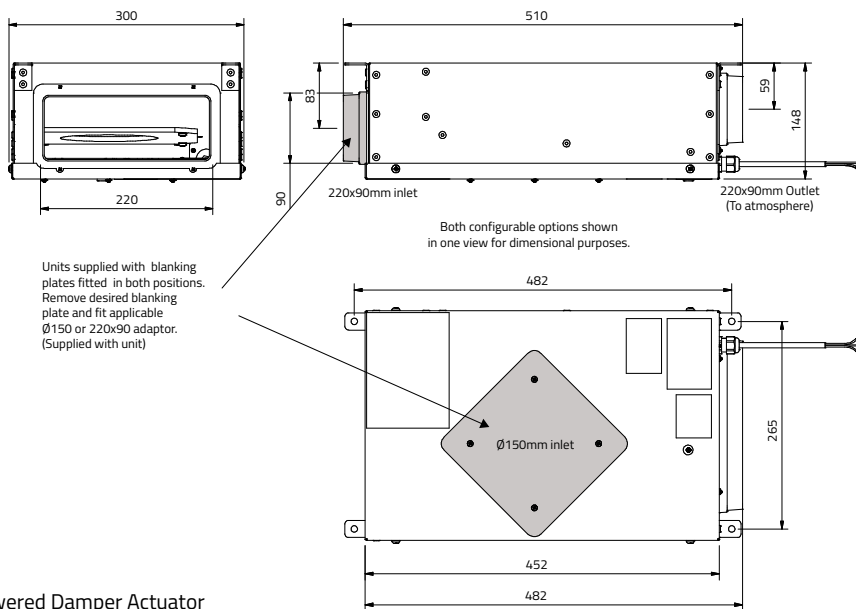

Powered Damper Actuator

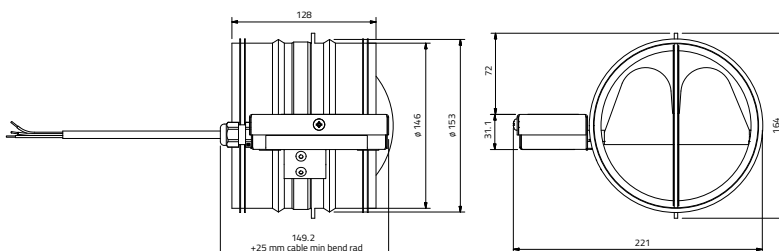

Dimensions in mm

Intermittent Fans - Axial

Extract Fans

For use in residential or non-residential applications

Ideal for air-extraction in bathroom, toilet and kitchens. Suitable to extract stale air directly to the outside or through short length ducting. Units can be wall/panel, ceiling and window mounted.

Versions

Run-on timer - The fan is equipped with a timer circuit adjustable from $\pm 1'$ to 25'. Operation: after switching off, the fan continues to run for the pre-set period of time.

Humidistat-timer - The fan is provided with an electronic circuit having a humidity sensor on board (adjustable from 50% to 95% RH) and a timer, adjustable from $\pm 1'$ to 25'. Operation: when the percentage of relative humidity is higher/lower than the pre-set threshold, the fan is automatically activated/deactivated. After switching off, the fan continues to run for the pre-set period of time.

Features & Benefits

- IPX4 protection degree
- Aesthetic front flat cover for modern interior design easily removed for cleaning
- Rigid optimised spigot support preventing distortion with strengthened guard and design to maximise airflow
- Integral back-draught shutter fitted as standard to prevent air flowing back into the room when the fan is off
- Low power consumption: 100mm model has less than 8 watts operating power consumption for energy saving
- Totally recyclable plastic components, environmentally friendly
- Double insulated: no earth connection is required
- Unique design winglet-type impeller, providing enhanced aerodynamic properties, low noise and increased efficiency
- Electrical supply 220-240 V ~ 50-60Hz

Extract



For use with Titon Trickle Ventilators.



Product Codes

TP241HT - TIFA100HT

Intermittent Fan Axial Ø100mm, Humidity and Timer

TP242T - TIFA120T

Intermittent Fan Axial Ø120mm, Run-on Timer

TP243T - TIFA150T

Intermittent Fan Axial Ø150mm, Run-on Timer

Standards

Designed and manufactured in accordance with EN60335-2-80 (Low Voltage Directive) and the EMC Directive (Electromagnetic Compatibility). Air performance measured according to ISO 5801 at 230V 50Hz, air density 1.2 Kg/m³. CE and UKCA marked.

Specification

Finish: White gloss RAL 9010, UV resistant

Materials: Shock-proof ABS casing

Guarantee period: 2 years (parts only)

Electrical: 220-240 V ~ 50Hz

Installation: To be installed accordance with the relevant and applicable building regulations.

Maintenance: Service, clean, replace subject to local environment - see product manual.

Drawing & Dimensions

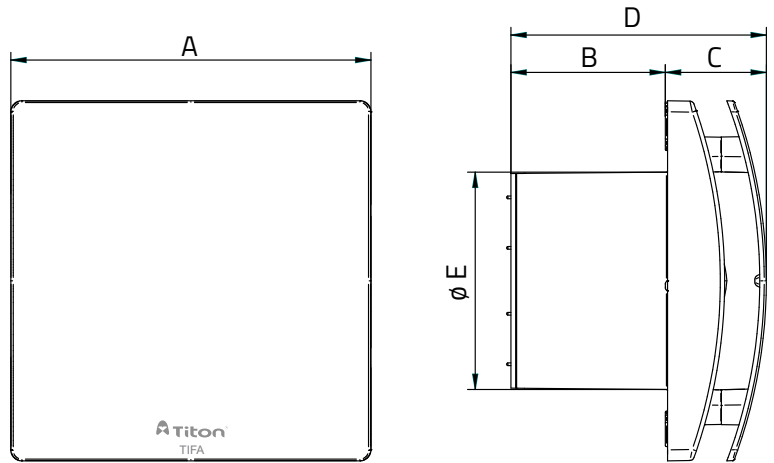

Dimensions in mm

Model Size	A	B	C	D	Ø E	Weight Kg
TIFA100HT	164	70	46	116	99	0.6
TIFA120T	184	81	48	129	119	0.9
TIFA150T	218	97	52	149	148	1.2

Dimensions in mm

Ceiling IPX4 Kit

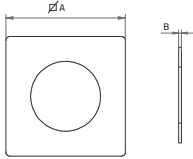

Model	TP202/ Ø100	TP205/ Ø120	TP205/ Ø150
A	173	196	230
B	5	5	5

Gasket made of EPDM rubber to guarantee the IPX4 degree of protection against moisture in case of ceiling installations.

Performance Details

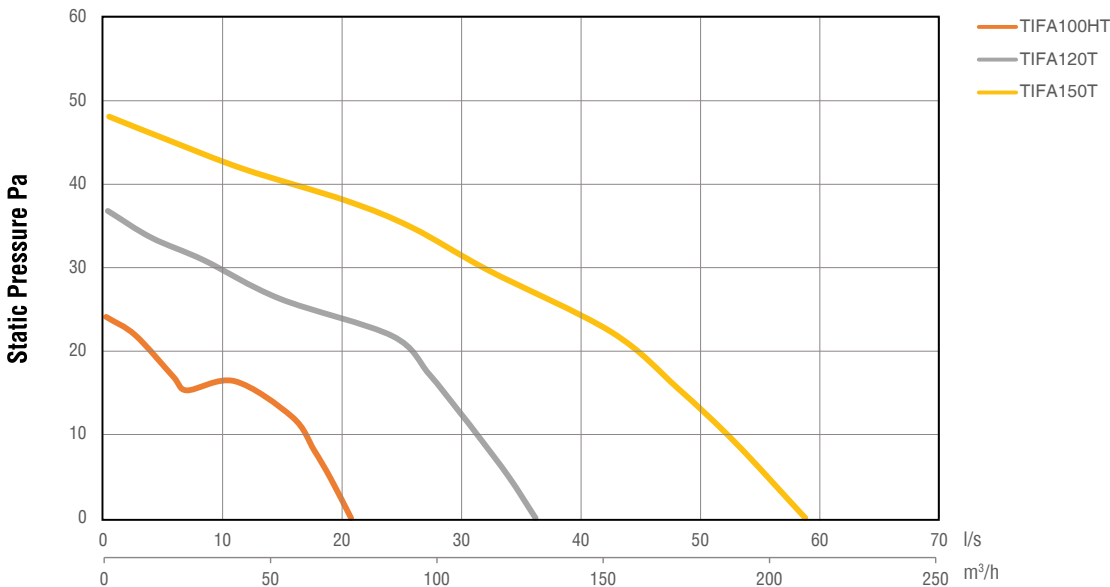

Volume Flow

Model	Airflow m³/h	Airflow l/s	Static pressure Pa max	Max power (W)	Sound pressure dB(A) @ 3m	Max ambient temp °C
TIFA100HT	75	21	24	8	26	50
TIFA120T	130	36	37	14	34	
TIFA150T	212	59	48	24	42	

Intermittent Fans - Centrifugal

Extract Fans

For use in residential or non-residential applications

Ideal for air-extraction in bathroom and small premises. A powerful extract fan, designed to overcome the resistances of long ducting systems. Units can be wall/panel and ceiling mounted: designed for surface or flush (plasterboard) installation.

Version

Humidistat & timer - The fan is provided with an electronic circuit having a humidity sensor on board (adjustable from 50% to 95% RH) and a timer, adjustable from $\pm 1'$ to 25'. Operation: when the percentage of relative humidity is higher/lower than the pre-set threshold, the fan is automatically activated/deactivated. After switching off, the fan continues to run for the pre-set period of time.

Features & Benefits

- IPX4 protection degree
- Aesthetic front flat cover for modern interior design easily removed for cleaning
- Removable filter in PP to protect the impeller and the motor. Easy to be removed for cleaning
- Integral back-draught shutter to prevent air flowing back into the room when the fan is off
- Improved performance thanks to the unique air straightener to optimise performance and reduce power consumption
- Totally recyclable plastic components, environmentally friendly
- Double insulated: no earth connection is required
- Forward curved centrifugal impeller, providing enhanced aerodynamic properties, low noise and increased efficiency.
- Electrical supply 220-240 V ~ 50-60Hz

Extract



For use with Titon Trickle Ventilators.



Product Codes

TP251HT - TIFC100HT
Intermittent Fan Centrifugal Ø100mm,
Humidity & Timer

Standards

Designed and manufactured in accordance with EN60335-2-80 (Low Voltage Directive) and the EMC Directive (Electromagnetic Compatibility).
Air performance measured according to ISO 5801 at 230V 50Hz, air density 1.2 Kg/m³. CE and UKCA marked.

Specification

Finish: White gloss RAL 9010, UV resistant

Materials: Shock-proof ABS casing

Weight: 1.87 Kg

Guarantee period: 2 years (parts only)

Electrical: 220-240 V ~ 50Hz

Installation: To be installed accordance with the relevant and applicable building regulations.

Maintenance: Service, clean, replace subject to local environment - see product manual.

Drawing & Dimensions

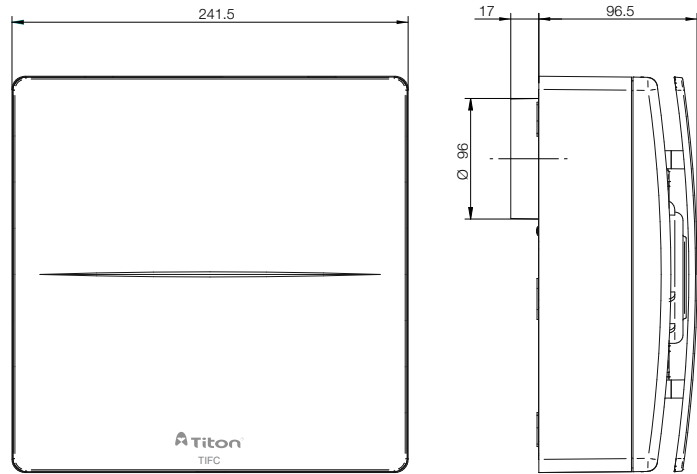

Dimensions in mm

Ceiling IPX4 Kit

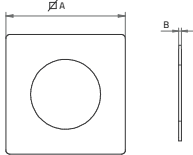

Model	TP206/ Ø100
A	255
B	5

Gasket made of EPDM rubber to guarantee the IPX4 degree of protection against moisture in case of ceiling installations.

Performance Details

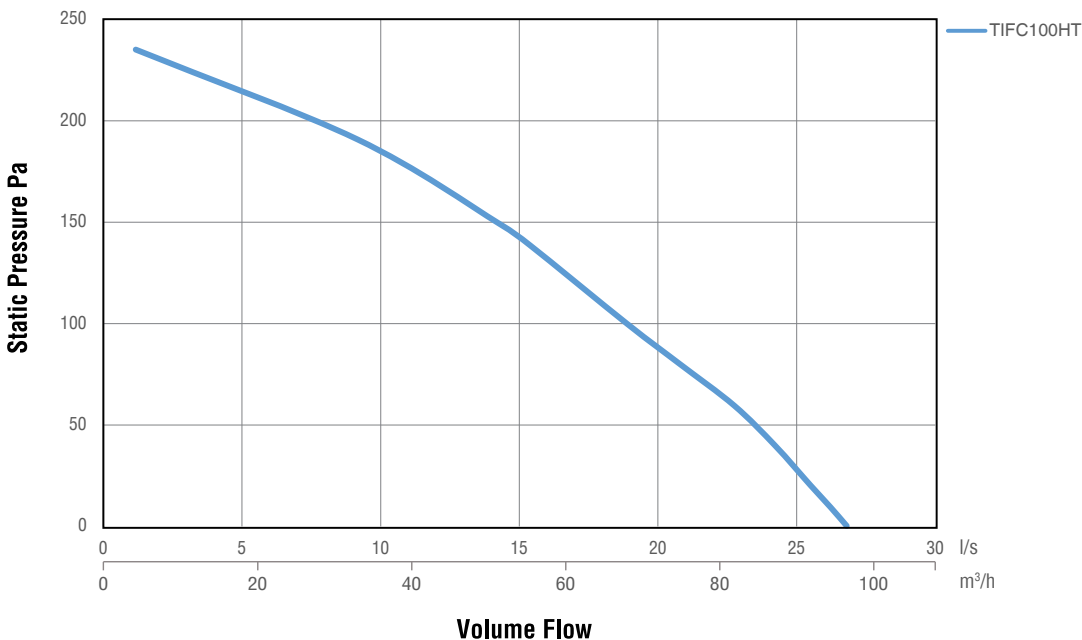

Model	Airflow m³/h max	Airflow l/s	Static pressure Pa max	Max power (W)	Sound pressure dB(A) @ 3m	Max ambient temp °C
TIFC100HT	97/61	27/17	235/146	28/17	38/27	50

Vent-Trex

Over-head extract fan / trickle ventilator

For use on PVCu, timber or aluminium windows

Vent-Trex is a unique combined overhead extract fan and trickle ventilator for kitchens and bathrooms that fits within the aperture on top of the window frame.

Vent-Trex is ideal for refurbishment situations where wall penetration is undesirable, as it does not damage the fabric of the building or where external aesthetics need to be preserved.

It provides a trickle ventilation performance Equivalent Area (EA) of 2500mm² minimum and extract ventilation rates to suit either kitchens or bathrooms.

Features & Benefits

- Unique combined extract fan/trickle ventilator
- Suitable for all window types
- Integral with window, ideal for refurbishment situations
- Avoids damage or penetration of building fabric
- Easy to install
- Saves wall space
- Low installation costs compared to traditional extract ventilators
- Bathroom version – single speed (15l/s)
- Kitchen version – two speed (60l/s and 30l/s)
- 2500mm² EA minimum
- Low energy usage
- Easy to clean
- Easy to maintain
- IP24 rating
- Humidistat option available (integral or remote)
- Available with remote PSU (SELV) option for bathrooms
- Continuous power or continuous running versions
- Variable speed version
- Suitable for use in conservation areas
- 2-year guarantee

Vent-Trex

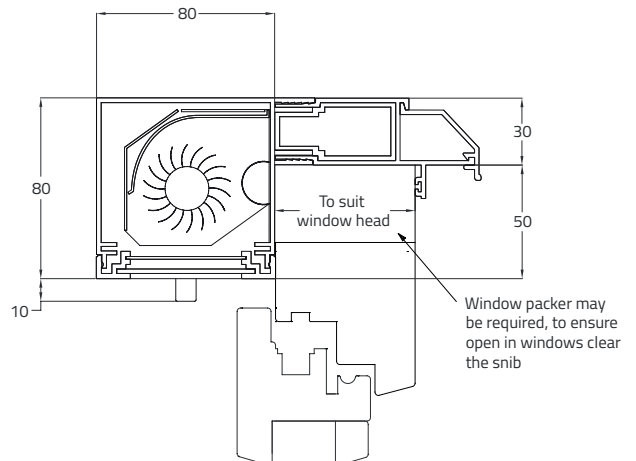

Details

Standard Version

The ceiling switch must be pulled to switch the unit on, where fitted humidity sensing will only trigger the unit when the unit is on.

The unit is provided with a number of different options, these being:-

- Built in humidity sensor, which triggers at a pre set relative humidity
- Remote PSU – low voltage option for bathrooms (12v)
- External mesh - reducing the likelihood of large insects, leaf etc. entering the unit.
- Remote Switching
- Slider – to close / open the unit

Continuous Power

The ceiling switch must be pulled to switch the unit on manually, the unit will always respond automatically to a change in humidity

The unit is provided with a number of different options, these being:-

- Remote PSU – low voltage option for bathrooms (12v)
- External mesh - reducing the likelihood of large insects, leaf etc. entering the unit.
- Remote switching
- Slider – to close / open the unit.

Always includes a built in humidity sensor, which trigger at a pre set relative humidity

Continuous Running

The fan will run at low speed continuously and increasing to the higher speed on switched on.

The unit is provided with one option, this being:-

- External mesh - reducing the likelihood of large insects, leaf etc. entering the unit
- Built in humidity sensor, which triggers at a pre set relative humidity

Always with integral PSU, no slider

General Options

- Hanging pull cord, and cable entry can be left or right handed (viewed from inside)
- Cable entry can front or end entry
- External mesh can be fitted.

	Minimum Length to Achieve 30l/s Low Speed 60 l/s high speed	Minimum achievable width*
Kitchen	1200mm	430mm

	Minimum Length to Achieve 15l/s	Minimum achievable width*
with integral PSU	540mm	430mm
Bathroom with external PSU	510mm (540mm with hum)	360mm (390mm with hum)

	Minimum Length to Achieve 30l/s Low Speed 60 l/s high speed	Minimum achievable width*
Kitchen	1200mm	430mm

	Minimum Length to Achieve 15l/s	Minimum achievable width*
Bathroom with integral PSU	540mm	430mm
Bathroom with external PSU	540mm	430mm

	Minimum Length to Achieve 8.7l/s Low Speed 21.6 l/s high speed	Minimum achievable width*
Kitchen	870mm	430mm

	Minimum Length to Achieve 8.6l/s Low Speed 11.8 l/s high speed	Minimum achievable width*
Bathroom	540mm	430mm
Bathroom with external PSU	540mm	430mm

Power Details	Finish
230V AC Voltage / Power Consumption (standard version) 12V Bathroom – 3.95W @ 15l/s (540mm length) (Integral PSU) 24V Kitchen – 21W @ 60l/s (1200mm length) (Integral PSU) Motor protection: IP24 Rating CE marked according to LVD and EMC directives	White finish as standard to RAL 9010. Can be supplied in different colours. External canopy and internal fan can be coloured independently. Details available on request.

Window Ventilators

Overview

Trickle ventilator range

Titon's range of window trickle ventilators includes improved designs which assist in compliance with Ventilation Regulations in England & Wales. Aluminium or PVCu models are available which offer increased ventilation that other ventilator manufacturers cannot match. This makes both the specifier and the window fabricators' jobs easier. The specifier can pick Titon products to ensure compliance for a choice of ventilation systems in different dwelling types, without constant specification change. The fabricator is safe in the knowledge that only the minimum number of ventilators required need to be used to achieve this compliance.

Trickle Vent



Typical Trimvent® Select Xtra pack

Need products to work with different ventilation systems?

What's more, specification is simple. The EA (Equivalent Area) is marked on each product for easy reference and vent and canopy or grille combinations have been tested in accordance with BS EN 13141:2004. The wide choice outlined in this brochure means compliance is possible when used with other products from Titon's mechanical ventilation range:

- **System 1** - Extract fans
- **System 3** - Continuous mechanical ventilation systems
- **System 4** - Continuous mechanical supply and extract with heat recovery

Please phone for available colours/finishes.

Remote Control option available on some of Titon's slot ventilator range.

For full product dimensions and fixing information, please visit www.titon.com and navigate to the relevant product's documentation page.



Thanks to our engineering expertise, the Trimvent® Select Xtra gives optimum airflow (and therefore Equivalent Area) utilising existing slot sizes. Specifically developed for Part F of the Building Regulations, Ventilation (England & Wales), and to improve performance for requirements throughout rest of the UK and Europe.

- No need to alter overall window designs to accommodate more vents or find additional vent locations. Select Xtra will do the job
- Improved opening gives optimum Equivalent Area
- Slot sizes as standard but products approximately 60% more efficient for airflow
- Based on extremely successful Trimvent® Select principle

Trimvent® Select Xtra S13

XS13 Ventilator & XC13 Canopy

For use on PVCu, timber or aluminium windows. Clip fix version available.

- Equivalent Area (mm²): 4400, 5000 (clip fix 4000, 5000)
- Free Area (mm²): 4106 (XS) and 4804 (XC), 5080 (XS) and 6055 (XC)
- Product Length: 411, 497
- Overall Slot Size: 367, 450 x 13



Trimvent® Select Xtra S16

XS16 Ventilator & XC16 Canopy

For use on PVCu or timber windows.

- Equivalent Area (mm²): 4600
- Free Area (mm²): 4507 (XS) and 4990 (XC)
- Product Length: 366
- Overall Slot Size: 312 x 16



Trimvent® Select Xtra R16

XR16 Ventilator & XHD16 Grille (or XC16 Canopy)

For use on timber windows.

- Equivalent Area (mm²): 4600
- Free Area (mm²): 4523 (XR) and 4608 (XHD)
- Product Length: 351
- Overall Slot Size: 352 x 16 (with 22 recess)



SF Xtra

SF Xtra Ventilator & SF Canopy

For use on PVCu, aluminium and Timber windows. Also available in bar length.

- Equivalent Area (mm²): 2500, 4000, 4400, 5000, 6000
- Free Area (mm²): 3000, 4000, 5000, 6000
- Product Length: 253, 294, 374, 400, 420, 434, 465, 529
- Overall Slot Size: (Length; see Product Fixing Instructions) x 13 or 16

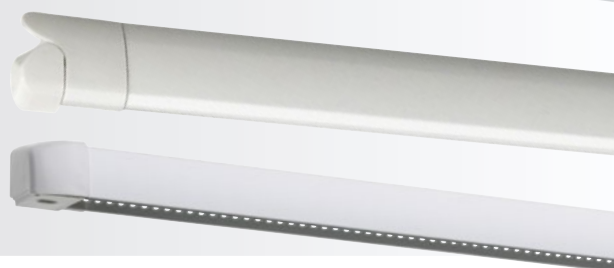

SF Xtra Sound Attenuator

SF Xtra SA Vent & SF SA Canopy

For use on PVCu, timber or aluminium windows.

- Equivalent Area (mm²): 2500, 5000
- Free Area (mm²): 3470, 5517
- Product length: 464, 523
- Overall Slot Size: 367 x 13 and 438 x 13
- Various combinations available to provide different levels of sound attenuation from Dn,e,w (C;Ctr) = 32 (1;1) dB through to Dn,e,w (C;Ctr) = 44 (-2;-3) dB

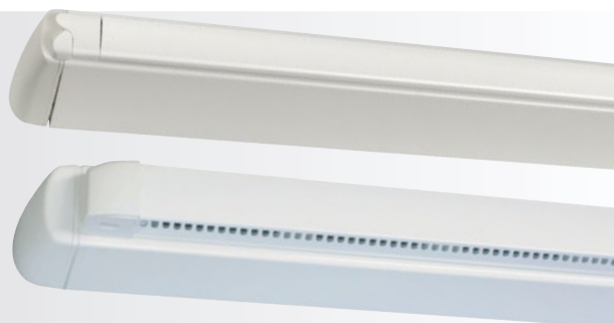

AirLiner

Acoustic (sound attenuating) telescopic air brick

For use fitted through walls

AirLiner is a rectangular acoustic (sound attenuating) air brick suitable for new build situations providing up to 10,500mm² EA.

AirLiner is available with a range of cowls and louvres or an internal hit & miss style ventilator and is available in white, buff/sand or terracotta moulded plastic finish.

Features & Benefits

- Acoustic (sound attenuating) telescopic cavity liner
- Cowl and Louvre (fixed) or Hit and Miss (adjustable) ventilator available in sets
- Baffle reduces sound, light and draughts
- Contains 3 unique acoustic panels
- Telescopic sleeve extends to suit opening. '9 x 6' Liner extends from 250 to 404mm (air brick fitted), '9 x 3' Liner extends from 250 to 368mm (air brick fitted)
- No special fixing required, Air Brick inserted into opening
- Effective in reducing pollutants in the home and improving Indoor Air Quality (IAQ), therefore reducing the risk of Toxic Home Syndrome.

Manufactured from

Liner – polypropylene with absorbent foam panels

Multifix® Air Brick (MFAB) – UV stabilised polypropylene,

Cowl, Louvre, Hit & Miss Ventilator – UV stabilised high impact polystyrene.

Standards

Measurement of airborne sound insulation was made in accordance with BS EN 20140-10: 1992.

Single number quantities were calculated in accordance with BS EN ISO 717-1:1997.

Equivalent area tested to BS EN 13141-1:2004 and independently verified by the BRE.

Also refer to: The Building Regulations 2000, Approved Document F.

The Building (Scotland) Regulations, Mandatory Standard 3.14.

The Building Regulations (Northern Ireland) 2000, Technical Booklet K.

British Standard BS 5250.

AirLiner





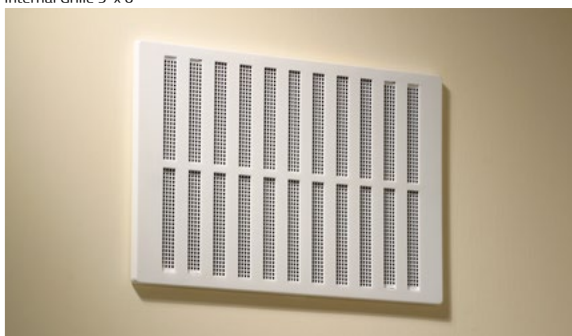

Internal Grille 9' x 6'



External Grille with Cowl



Details

Order and Specification Code	Main Uses, Features and Benefits	Size	Equivalent Area	Colours
TAL4H&M	'9x3' Acoustic AirLiner® Set with Hit & Miss Ventilator (Up to 39 dB Dn,e,w)			
	<ul style="list-style-type: none"> Controllable air vent for background room ventilation Acoustic lining reduces sound by 38 dB with internal grille fully open and 39 dB when closed (Dn,e,w) Internal baffle reduces light and draughts. Internal hit & miss grille manually adjusted with an easy sliding action giving control over air flow External baffles prevent cross cavity water transfer Internal and external grilles U.V. stabilised New higher equivalent area confirmed by the BRE Acoustic performance tests by BRE Acoustics. 	<p>AirLiner: Extends from 250-368mm L with air brick fitted</p> <p>Hit & Miss: 271mm L x 95mm H</p>	6300mm ² 63cm ²	<p>Air Brick: Terracotta, buff/sand, white, grey, blue/black, black, brown</p> <p>Hit & Miss: Magnolia (may be decorated)</p>
TALH&M	'9x6' Acoustic AirLiner® Set with Hit & Miss Ventilator (Up to 40 dB Dn,e,w)			
	<ul style="list-style-type: none"> Controllable air vent for background room ventilation Acoustic lining reduces sound by 39 dB with internal grille fully open and 40 dB when closed (Dn,e,w) Internal baffles reduce light and draughts Internal hit & miss grille manually adjusted with an easy sliding action giving control over air flow External baffles prevent cross cavity water transfer Internal and external grilles U.V. stabilised New higher equivalent area confirmed by the BRE Acoustic performance tests by BRE Acoustics. 	<p>AirLiner: Extends from 250-404mm L with air brick fitted</p> <p>Hit & Miss: 271mm L x 171mm H</p>	10500mm ² 105cm ²	<p>Air Brick: Terracotta, buff/sand, white, grey, blue/black, black, brown</p> <p>Hit & Miss: White</p>
TAL4HMCWL	'9x3' Cowl'd Acoustic AirLiner® Set with Hit & Miss Ventilator (Up to 40 dB Dn,e,w)			
	<ul style="list-style-type: none"> Controllable air vent for background room ventilation Acoustic lining reduces sound by 39 dB with internal grille fully open and 40 dB when closed (Dn,e,w) Cowl and internal baffle reduces light and draughts Internal hit & miss grille manually adjusted with an easy sliding action giving control over air flow External baffles prevent cross cavity water transfer Cowl and grilles U.V. stabilised New higher equivalent area confirmed by the BRE Acoustic performance tests by BRE Acoustics. 	<p>Cowl: 255mm L x 96mm H x 44mm D</p> <p>AirLiner: Extends from 250-368mm L with air brick fitted</p>	6300mm ² 63cm ²	<p>Cowl & Air Brick: Terracotta, buff/sand</p> <p>Hit & Miss: White</p>
TALHMCW	'9x6' Cowl'd Acoustic AirLiner® Set with Hit & Miss Ventilator (Up to 42 dB Dn,e,w)			
	<ul style="list-style-type: none"> Controllable air vent for background room ventilation Acoustic lining reduces sound by 42 dB Dn,e,w with internal grille fully open or closed Cowl and internal baffles reduce light and draughts Internal hit & miss grille manually adjusted with an easy sliding action giving control over air flow External baffles prevent cross cavity water transfer Cowl and grilles U.V. stabilised New higher equivalent area confirmed by the BRE Acoustic performance tests by BRE Acoustics. 	<p>Cowl: 255mm L x 154mm H x 74mm D</p> <p>AirLiner: Extends from 250-404mm L with air brick fitted</p>	9800mm ² 98cm ²	<p>Cowl & Air Brick: Terracotta, buff/sand</p> <p>Hit & Miss: White</p>

Drawing and Dimensions

TALH&M/TALHMCW

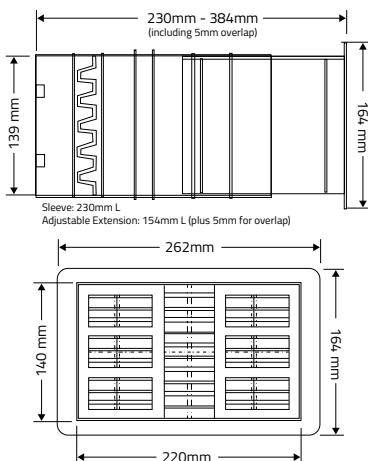

TAL4H&M/TAL4HMCWL

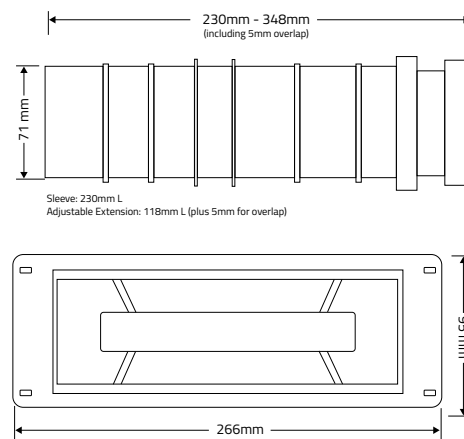

©Ryttons

AirCore

Acoustic (sound attenuating) wall ventilator

For use fitted through walls

The new LookRyt AirCore is a permanent circular super acoustic (sound attenuating) wall ventilator suitable for new build and refurbishment situations.

This super acoustic ventilator can provide soundproofing up to 50 dB (Dn,e,w) and up to 8500mm² EA. LookRyt AirCore is available with a range of cowls and louvres and is available in white, buff/sand or terracotta moulded plastic finish.

Features & Benefits

- Controllable air vent for background room ventilation
- Core drilled - suitable for retrofit installations
- Unique internal LookRyt panel disperses air evenly and may be painted or wallpapered to match décor
- External grille U.V. stabilised
- Verifiable equivalent area confirmed by the BRE
- Injection moulded one piece tube makes handling easier and installation quicker
- Acoustic performance tests by BRE Acoustics
- Effective in reducing pollutants in the home and improving Indoor Air Quality (IAQ), therefore reducing the risk of Toxic Home Syndrome.

Manufactured from

Tube – High impact polystyrene with absorbent foam lining.

External and Internal louvres – UV stabilised high impact polystyrene.

Maximum length 358mm, minimum length 295mm.

Standards

Measurement of airborne sound insulation was made in accordance with BS EN 20140-10: 1992.

Single number quantities were calculated in accordance with BS EN ISO 717-1:1997.

Equivalent area tested to BS EN 13141-1:2004 and independently verified by the BRE.

Also refer to: The Building Regulations 2000, Approved Document F.

The Building (Scotland) Regulations, Mandatory Standard 3.14.

The Building Regulations (Northern Ireland) 2000, Technical Booklet K.

British Standard BS 5250.

AirCore



Internal Grille



External Grille with Cowl



External Grille

Details

Order and Specification Code	Main Uses, Features and Benefits	Size	Equivalent Area	Colours
AAC125HP	Super Acoustic Controllable LookRyt® AirCore® (Up to 50 dB Dn,e,w)			
	<ul style="list-style-type: none"> Controllable air vent for background room ventilation Core drilled - suitable for retrofit installations Acoustic lining reduces sound by 43 dB with internal panel fully open and 50 dB when closed (Dn,e,w) Unique internal LookRyt panel disperses air evenly and may be painted or wallpapered to match décor External grille U.V. stabilised Verifiable equivalent area confirmed by the BRE Acoustic performance tests by BRE Acoustics Fixing screws for LookRyt panel provided in all set. 	<p>Ext. Grille: 166mm L x 160mm H</p> <p>Tube: 127mm Dia. x 358mm L</p> <p>LookRyt Panel: 172mm L x 172mm H</p>	<p>8500mm²</p> <p>85cm²</p>	<p>Ext. Grille: Terracotta, buff/sand, white</p> <p>LookRyt Panel: Magnolia (may be decorated)</p>
AAC125HPCWL	Cowled Super Acoustic Controllable LookRyt® AirCore® (Up to 50 dB Dn,e,w)			
	<ul style="list-style-type: none"> Controllable air vent for background room ventilation Core drilled - suitable for retrofit installations Acoustic lining reduces sound by 45 dB with internal panel fully open and 50 dB when closed (Dn,e,w) External cowl reduces light and draughts Unique internal LookRyt panel disperses air evenly and may be painted or wallpapered to match décor External cowl and grille U.V. stabilised Verifiable equivalent area confirmed by the BRE Acoustic performance tests by BRE Acoustics. 	<p>Cowl: 217mm L x 210mm H x 93mm D</p> <p>Tube: 127mm Dia. x 358mm L</p>	<p>8400mm²</p> <p>84cm²</p>	<p>Cowl and Ext. Grille: Terracotta, buff/sand, white</p> <p>LookRyt Panel: Magnolia (may be decorated)</p>
AAH125HP	High Rise Super Acoustic Controllable LookRyt® AirCore® (Up to 50 dB Dn,e,w)			
	<ul style="list-style-type: none"> Controllable air vent for background room ventilation Core drilled - suitable for retrofit installations Fitted from the inside for high rise constructions Acoustic lining reduces sound by 44 dB with internal panel fully open and 50 dB when closed (Dn,e,w) Unique internal LookRyt panel disperses air evenly and may be painted or wallpapered to match décor External grille U.V. stabilised Verifiable equivalent area confirmed by the BRE Acoustic performance tests by BRE Acoustics. 	<p>Tube: 127mm Dia. x 358mm L</p> <p>LookRyt Panel: 172mm L x 172mm H</p>	<p>7700mm²</p> <p>77cm²</p>	<p>Ext. Grille: Terracotta, buff/sand, white</p> <p>LookRyt Panel: Magnolia (may be decorated)</p>

100mm - Round Ducting

plus Accessories and Terminals

Ø100mm PVC	Product Code	Free Area = 7,855mm ²	Static Pressure Drop (in Pa)		
		Components	8l/s	15l/s	30l/s
	8960097	Round Duct - 350mm Long	0.1	0.2	0.5
	8960110	Round Duct - 1.0m Long	0.1	0.5	1.4
	8960140	Round Duct - 1.5m Long	0.2	0.8	2.1
	ENQ	Round Duct - 2m Long	0.2	1.0	2.8
	8960142	90° Bend	1.6	5.6	21.1
	8960143	45° Bend	0.6	2.1	8.2
	8960144	Tee Piece	n/a		
	8960031	Duct Connector	0.3	0.9	4.2
	8960145	Duct Connector with Backdraught Damper	7.1	25.0	44.9
	8960146	Fixing Bracket	n/a		
	8960188	Jubilee Clip - 55mm to 170mm	n/a		
	*8960227	Ceiling Metal Vent Diffuser - Extract	5.0	13.4	53.7
	*8960229	Ceiling Metal Vent Diffuser - Supply	6.2	16.5	66.5
	Product Code	Terminations	8l/s	15l/s	30l/s
	8960105	External Louvred Grille (Free Area; 3,809mm ²) - White 	1.7	6.0	19.8
	8960102	External Louvred Grille (Free Area; 3,809mm ²) - Brown 			
	8960104	External Louvred Grille (Free Area; 3,809mm ²) - Terracotta 			
	8960103	External Louvred Grille (Free Area; 3,809mm ²) - Beige 			
	8960107	External Cowled Grille (Free Area; 7,200mm ²) - White (With non-return flap) 	1.3	4.7	17.2
	8960106	External Cowled Grille (Free Area; 7,200mm ²) - Brown (With non-return flap) 			
	8960239	External Cowled Grille (Free Area; 7,200mm ²) - Terracotta (With non-return flap) 			
	8960223	External High-Rise Grille (Free Area; 6,499mm ²) - White 	0.0	0.1	4.2
	8960222	External High-Rise Grille (Free Area; 6,499mm ²) - Brown 			
	8960112	External Round Grille (Free Area; 4,007mm ²) - with fly screen	4.3	15.0	48.1
	8960079	External Mushroom Cowling	n/a		

*Pressure losses with control disc 10mm open.

100mm - Round Ducting

plus Accessories and Terminals

Ø100mm PVC	Product Code	Free Area = 7,855mm ²	Static Pressure Drop (in Pa)		
		Components	8l/s	15l/s	30l/s
	8960062	Round – 1m length	n/a		
	8960064	Round – 3m length	n/a		
	8960067	Round – 6m length	n/a		
	8960070	Round – 15m length	n/a		
	8960073	Round – 45m length	n/a		
	Product Code	Insulated Flexible	8l/s	15l/s	30l/s
	8960052	Aluminium – 5m length	n/a		
	8960051	Aluminium - 10m length	n/a		
	Product Code	Fire Protection	8l/s	15l/s	30l/s
	*8960228	Ceiling Metal Vent Diffuser - Extract with Fire Damper (Fire Rating 60 mins)	5.0	13.4	53.7
	QRS110	Ø100mm Fire Sleeve (Fire Rating 120 mins)	n/a		
	CFC100	CFC Ceiling Fan Cuff	n/a		
	FW100X100	Intumescent Wrap (Fire Rating 120 mins) to work with	n/a		
	FWS100X141	Metal Retaining Sleeve - for partition walls up to 132mm	n/a		
	Product Code	Insulation	8l/s	15l/s	30l/s
	89706	Insulation Jacket - 25mm Thick (10m Roll)	n/a		

*Pressure losses with control disc 10mm open.

125mm - Round Ducting

plus Accessories and Terminals

Ø125mm PVC	Product Code	Free Area = 12,273mm ²	Static Pressure Drop (in Pa)		
		Components	8l/s	15l/s	30l/s
	8960114	Round Duct - 350mm Long	0.0	0.1	0.3
	8960115	Round Duct - 1.0m Long	0.1	0.2	0.7
	8960120	Round Duct - 1.5m Long	0.1	0.3	1.0
	8960161	Round Duct - 2m Long	0.1	0.4	1.4
	8960148	90° Bend	0.6	2.0	8.4
	8960149	45° Bend	0.2	0.7	2.9
	8960150	Tee Piece	n/a		
	8960184	Adaptor - Ø125mm to Ø100mm	0.4	1.5	5.9
	8960153	Duct Connector	0.1	0.2	0.9
	8960151	Duct Connector with Backdraught Damper	5.2	18.3	31.5
	8960251	Self Seal Connector - Duct to Duct	0.1	0.2	0.9
	8960373	Rapid Self Seal Connector - 90° Bend	0.5	1.3	7.0
	8960374	Rapid Self Seal Connector - T-Piece	n/a		
	8960152	Fixing Bracket	n/a		
	8960188	Jubilee Clip - 55mm to 170mm	n/a		
	*8960230	Ceiling Metal Vent Diffuser - Extract	6.0	12.6	36.4
	*8960232	Ceiling Metal Vent Diffuser - Supply	6.0	12.6	36.4
	*9030001	Ceiling Plastic Vent Diffuser - Extract	5.6	19	76
		Ceiling Plastic Vent Diffuser - Supply	4.5	15	60
	TP520	G3 Conical filter for Metal Extract Diffuser (8960230)	n/a		
	8960001	125mm Condensate Trap Kit	n/a		
	Product Code	Terminations	8l/s	15l/s	30l/s
	8960119	External Louvred Grille (Free Area; 6,123mm ²) - White 	1.3	4.6	18.4
	8960116	External Louvred Grille (Free Area; 6,123mm ²) - Brown 			
	8960118	External Louvred Grille (Free Area; 6,123mm ²) - Terracotta 			
	8960117	External Louvred Grille (Free Area; 6,123mm ²) - Beige 			
	8960134	External Cowled Grille (Free Area; 6,560mm ²) - White (With non-return flap) 	1.5	5.2	19.8
	8960132	External Cowled Grille (Free Area; 6,560mm ²) - Brown (With non-return flap) 			
	8960133	External Cowled Grille (Free Area; 6,560mm ²) - Terracotta (With non-return flap) 			

*Pressure losses with control disc 10mm open.

125mm - Round Ducting

plus Accessories and Terminals

Ø125mm PVC	Product Code	Free Area = 12,273mm ²	Static Pressure Drop (in Pa)		
		Flexible PVC Duct	8l/s	15l/s	30l/s
	8960063	Round – 1m length	n/a		
	8960065	Round – 3m length	n/a		
	8960068	Round – 6m length	n/a		
	8960071	Round – 15m length	n/a		
	Product Code	Insulated Flexible	8l/s	15l/s	30l/s
	8960054	Aluminium – 5m length	n/a		
	8960053	Aluminium - 10m length	n/a		
	Product Code	Fire Protection	8l/s	15l/s	30l/s
	*8960231	Ceiling Metal Vent Diffuser - Extract with Fire Damper (Fire Rating 60 mins)	6.0	12.6	36.4
	*8960233	Ceiling Metal Vent Diffuser - Supply with Fire Damper (Fire Rating 60 mins)	6.0	12.6	36.4
	QRS130	Ø125mm Fire Sleeve (Fire Rating 90 mins)	n/a		
	FSK125W	Intumescent Wrap & Sleeve Kit - for partition walls up to 132mm (Fire Rating 120 mins)	n/a		
	Product Code	Attenuation	8l/s	15l/s	30l/s
	CA125600	Galvanized Attenuator - 0.6m long (Ø235mm OD)	0.1	0.1	0.5
	CA125900	Galvanized Attenuator - 0.9m long (Ø235mm OD)	0.1	0.2	0.7
	CA1251200	Galvanized Attenuator - 1.2m long (Ø235mm OD)	0.1	0.3	0.9
	89720	Flexible Silencer - 0.5m long (Ø175mm OD)	n/a		
	89721	Flexible Silencer - 1.0m long (Ø175mm OD)	n/a		
	Product Code	Insulation	8l/s	15l/s	30l/s
	89701	Insulation Jacket - 25mm Thick (10m Roll)	n/a		
	8960299	Round Thermal Duct with connector - 1.0m Long	0.1	0.2	0.8
	8960300	Round Thermal Duct with connector - 2.0m Long	0.2	0.5	1.7
	8960303	Thermal 90° Bend with connectors	0.4	1.3	4.9
	8960304	Thermal 45° Bend with connectors	0.1	0.4	1.5
	8960305	Thermal Tee Piece with connectors	n/a		
	8960306	Thermal Self Seal Connector - Duct to Duct	0.1	0.2	0.9
	8960307	Thermal Self Seal Connector - Duct to Fitting	0.1	0.2	0.9

*Pressure losses with control disc 10mm open.

150mm - Round Ducting

plus Accessories and Terminals

Ø150mm PVC	Product Code	Free Area = 12,273mm ²	Static Pressure Drop (in Pa)		
		Components	30l/s	60l/s	90l/s
	8960191	Round Duct - 350mm Long	0.1	0.4	0.9
	8960192	Round Duct - 1.0m Long	0.4	1.2	2.7
	8960193	Round Duct - 1.5m Long	0.6	1.8	4.1
	ENQ	Round Duct - 2m Long	0.8	2.4	5.4
	8960155	90° Bend	4.2	18.2	41.0
	8960296	45° Bend	1.2	4.8	10.8
	8960156	Tee Piece	n/a		
	8960190	Adaptor - Ø150mm to Ø125mm	2.2	8.8	19.8
	8960158	Duct Connector	0.2	1.1	2.5
	8960157	Duct Connector with Backdraught Damper	23.5	43.6	98.1
	8960188	Jubilee Clip - 55mm to 170mm	n/a		
	*8960234	Ceiling Metal Vent Diffuser - Extract	3.5	12.5	49.6
	*8960235	Ceiling Metal Vent Diffuser - Supply	4.0	14.5	57.4
	TP521	G3 Conical filter with Metal Extract Diffuser (8960234)	n/a		
	8960002	150mm Condensate Trap Kit	n/a		
	Product Code	Terminations	30l/s	60l/s	90l/s
	8960130	External Louvred Grille (Free Area; 11,440mm ²) - White 	3.0	12.3	27.7
	8960126	External Louvred Grille (Free Area; 11,440mm ²) - Brown 			
	8960129	External Louvred Grille (Free Area; 11,440mm ²) - Terracotta 			
	8960127	External Louvred Grille (Free Area; 11,440mm ²) - Beige 			

*Pressure losses with control disc 10mm open.

150mm - Round Ducting

plus Accessories and Terminals

Ø150mm PVC	Product Code	Free Area = 12,273mm ²	Static Pressure Drop (in Pa)		
		Flexible PVC Duct	30l/s	60l/s	90l/s
	8960061	Round - 1m length	n/a		
	8960066	Round - 3m length	n/a		
	8960069	Round - 6m length	n/a		
	8960072	Round - 15m length	n/a		
	Product Code	Insulated Flexible	30l/s	60l/s	90l/s
	8960056	Aluminium - 5m length	n/a		
	8960055	Aluminium - 10m length	n/a		
	Product Code	Fire Protection	30l/s	60l/s	90l/s
	*8960274	Ceiling Metal Vent Diffuser - Extract with Fire Damper (Fire Rating 60 mins)	3.5	12.5	49.6
	*8960275	Ceiling Metal Vent Diffuser - Supply with Fire Damper (Fire Rating 60 mins)	4.0	14.5	57.4
	FSK150C	Intumescent Fire Cuff - for partition walls up to 132mm (Fire Rating 90 mins)	n/a		
	Product Code	Attenuation	30l/s	60l/s	90l/s
	CA150600	Galvanized Attenuator - 0.6m long (Ø270mm OD)	0.4	1.0	2.3
	89722	Flexible Silencer - 0.5m long (Ø200mm OD)	n/a		
	89723	Flexible Silencer - 1.0m long (Ø200mm OD)	n/a		
	Product Code	Insulation	30l/s	60l/s	90l/s
	89702	Insulation Jacket - 25mm Thick (10m Roll)	n/a		
Ø160mm PVC	Product Code	Free Area = 20,106mm ²	Static Pressure Drop (in Pa)		
		Insulation	30l/s	60l/s	90l/s
	8960327	Round Thermal Duct with connector - 1.0m Long	0.3	1.1	2.5
	8960328	Round Thermal Duct with connector - 2.0m Long	0.5	2.0	4.3
	8960329	Thermal 90° Bend with connectors	1.5	5.7	12.7
	8960330	Thermal 45° Bend with connectors	0.4	1.6	3.6
	8960331	Thermal Tee Piece with connectors	n/a		
	8960335	Thermal - Ø160mm to Ø150mm Adaptor	0.2	1.1	2.5
	8960332	Thermal Self Seal Connector - Duct to Duct	0.2	1.1	2.5
	8960333	Thermal Self Seal Connector - Duct to Fitting	0.2	1.1	2.5

*Pressure losses with control disc 10mm open.

110x54mm - Rectangular Ducting

plus Accessories and Terminals

110x54mm PVC	Product Code	Free Area = 5,424mm ²	Static Pressure Drop (in Pa)		
		Components	8l/s	15l/s	30l/s
	8960109	Rectangular Duct - 1.0m Long	0.6	2.2	8.6
	8960096	Rectangular Duct - 1.5m Long	0.9	3.3	12.8
	ENQ	Rectangular Duct - 2m Long	1.2	4.4	17.1
	8960094	90° Bend - Horizontal	2.8	9.8	39.8
	8960081	45° Bend - Horizontal	1.1	3.7	15.5
	8960095	90° Bend - Vertical	4.4	15.6	62.8
	8960003	45° Bend - Vertical	0.7	2.6	12.7
	8960082	Tee Piece	n/a		
	8960091	Duct Connector	0.1	0.3	1.4
	8960131	Flexible Duct Connector	0.1	0.3	1.4
	8960084	Fixing Bracket	n/a		
	8960108	110x54mm to 204x60mm Horizontal Adaptor	n/a		
	8960111	110x54mm to Ø100mm Horizontal Adaptor	1.1	3.7	14.6
	8960080	110x54mm to Ø100mm Horizontal Short Adaptor - Male	1.4	4.8	20.4
	8960093	110x54mm to Ø100mm Vertical Adaptor - Male	2.3	8.1	33.1
	8960092	110x54mm to Ø100mm Vertical Adaptor - Female	2.3	8.1	33.1
	Product Code	Terminals	8l/s	15l/s	30l/s
	8960089	External Louvred Grille (Free Area; 2,600mm ²) - Brown 	4.3	15.0	48.1
	8960090	External Louvred Grille (Free Area; 2,600mm ²) - Terracotta 			
	8960088	External Cowled Grille (Free Area; 5,800mm ²) - White 	2.4	8.4	30.4
	8960085	External Cowled Grille (Free Area; 5,800mm ²) - Brown 			
	8960086	External Cowled Grille (Free Area; 5,800mm ²) - Beige 			
	8960087	External Cowled Grille (Free Area; 5,800mm ²) - Terracotta 			
	Product Code	Flexible PVC Duct	8l/s	15l/s	30l/s
	8960074	Rectangular – 1m length	n/a		
	8960076	Rectangular – 3m length	n/a		
	Product Code	Fire Protection	8l/s	15l/s	30l/s
	QRS110/54	110x54mm Fire Sleeve (Fire Rating 120 mins)	n/a		
	QRS110/54SS	110x54mm Fire Slim Sleeve (Fire Rating 120 mins)	n/a		
	FW110X54X100	Intumescent Wrap (Fire Rating 120 mins) to work with	n/a		
	FWS110X54X141	Metal Retaining Sleeve - for partition walls up to 132mm	n/a		

234x29mm - Rectangular Ducting

plus Accessories and Terminals

234x29mm PVC	Product Code	Free Area = 5,575mm ²	Static Pressure Drop (in Pa)		
		Components	8l/s	15l/s	30l/s
	8960205	Rectangular Duct - 1.0m Long	1.6	5.5	18.0
	8960197	90° Bend - Horizontal	2.9	10.3	38.1
	8960210	45° Bend - Horizontal	2.1	7.5	26.4
	8960209	90° Bend - Vertical	1.6	5.5	19.9
	8960208	45° Bend - Vertical	1.7	6.1	21.1
	8960196	Duct Connector	0.0	0.1	0.3
	8960204	Fixing Bracket	n/a		
	8960207	234x29mm to Ø100mm Horizontal Adaptor	1.3	4.6	16.1
	8960198	234x29mm to Ø100mm Vertical Adaptor	3.2	11.1	38.2
	Product Code	Fire Protection	8l/s	15l/s	30l/s
	FW225X25X100	Intumescent Wrap (Fire Rating 120 mins) to work with	n/a		
	FWS225X25X141	Metal Retaining Sleeve - for partition walls up to 132mm	n/a		

204x60mm - Rectangular Ducting

plus Accessories and Terminals

204x60mm PVC	Product Code	Free Area = 11,452mm ²	Static Pressure Drop (in Pa)		
		Components	8l/s	15l/s	30l/s
	8960162	Rectangular Duct - 0.5m Long	0.1	0.3	1.0
	8960163	Rectangular Duct - 1.0m Long	0.1	0.5	2.0
	8960176	Rectangular Duct - 1.5m Long	0.2	0.8	3.0
	8960177	Rectangular Duct - 2m Long	0.3	1.1	3.9
	8960164	90° Bend - Horizontal	0.5	1.8	7.5
	8960172	45° Bend - Horizontal	0.2	0.6	2.7
	8960168	90° Bend - Vertical	0.3	1.1	4.5
	8960173	45° Bend - Vertical	0.2	0.6	2.7
	8960178	Tee Piece	n/a		
	8960166	Duct Connector	0.0	0.1	0.3
	8960252	Self Seal Connector - Duct to Duct	0.1	0.2	0.9
	8960253	Self Seal Connector - Duct to Fitting	0.1	0.2	0.9
	8960369	Rapid Self Seal Connector - Horizontal Self-Seal T-piece	n/a		
	8960167	Fixing Bracket	n/a		
	8960006	Cross-Over Piece	0.2	0.7	2.9
	8960169	204x60mm to Ø125mm Horizontal Adaptor	0.3	1.0	3.8
	8960174	204x60mm to Ø100mm Vertical Adaptor	0.4	1.4	5.3
	8960165	204x60mm to Ø125mm Vertical Adaptor	0.5	1.7	6.9
	8960175	204x60mm to Ø150mm Vertical Adaptor	0.5	1.8	7.4
	Product Code	Terminations	8l/s	15l/s	30l/s
	TA350/392	Hi Flow Air Brick (Free Area; 8,670mm ²) - White 	0.6	2.2	7.8
	TA350/315	Hi Flow Air Brick (Free Area; 8,670mm ²) - Brown 			
	TA350/094	Hi Flow Air Brick (Free Area; 8,670mm ²) - Terracotta 			
	TA350/093	Hi Flow Air Brick (Free Area; 8,670mm ²) - Beige 			
	TA350/010	Hi Flow Air Brick (Free Area; 8,670mm ²) - Grey 			
	Product Code	Terminations	15l/s	30l/s	60l/s
	8960343	Double Airbrick Adapter with Grilles (Free Area; 15,360mm ²) - White 	0.9	3.30	8.40
	8960341	Double Airbrick Adapter with Grilles (Free Area; 15,360mm ²) - Brown 			
	8960340	Double Airbrick Adapter with Grilles (Free Area; 15,360mm ²) - Terracotta 			
	8960344	Double Airbrick Adapter with Grilles (Free Area; 15,360mm ²) - Beige 			





204x60mm - Rectangular Ducting

plus Accessories and Terminals

204x60mm PVC	Product Code	Free Area = 11,452mm ²	Static Pressure Drop (in Pa)		
		Flexible PVC Duct	8l/s	15l/s	30l/s
	8960075	Rectangular – 1m length	n/a		
	8960077	Rectangular – 3m length	n/a		
	Product Code	Fire Protection	8l/s	15l/s	30l/s
	QRS205/60	204x60mm Fire Sleeve (Fire Rating 120 mins)	n/a		
	QRS204/60SS	204x60mm Fire Slim Sleeve (Fire Rating 90 mins)	n/a		
	FW204X60X100	Intumescent Wrap (Fire Rating 120 mins) to work with	n/a		
	FWS204X60X141	Metal Retaining Sleeve - for partition walls up to 132mm	n/a		
	Product Code	Attenuation	8l/s	15l/s	30l/s
	8960256	Cross-Talk Silencer - 0.5m Long (Free Area; 5,264mm ²)	2.9	10.5	18.5
	8960242	Cross-Talk Silencer - 1.0m Long (Free Area; 5,264mm ²)	3.0	10.4	17.2
	8960257	Cross-Talk Silencer - 1.5m Long (Free Area; 5,264mm ²)	2.3	8.2	23.5
	8960290	Hi-Flow Attenuator - 0.5m Long (Free Area; 11,664mm ²)	0.4	1.5	7.8
	8960291	Hi-Flow Attenuator - 1.0m Long (Free Area; 11,664mm ²)	0.5	1.8	8.0
	8960292	Hi-Flow Attenuator - 1.5m Long (Free Area; 11,664mm ²)	0.6	2.0	9.3
	Product Code	Insulation	8l/s	15l/s	30l/s
	89703	Insulation Jacket - 25mm Thick (10m Roll)	n/a		
	8960308	Rectangular Thermal Duct with connector - 1.0m Long	0.2	0.5	1.6
	8960309	Rectangular Thermal Duct with connector - 2.0m Long	0.0	0.5	2.6
	8960310	Thermal 90° Horizontal Bend with connectors	0.0	0.9	4.7
	8960311	Thermal 45° Horizontal Bend with connectors	0.0	0.0	1.3
	8960313	Thermal 90° Vertical Bend with connectors	0.0	0.6	3.6
	8960314	Thermal 45° Vertical Bend with connectors	0.0	0.0	0.4
	8960312	Thermal Tee Piece with connectors	n/a		
	8960315	Thermal 204x60mm to Ø125mm Plenum Adaptor	0.5	2.1	7.9
	8960316	Thermal Self Seal Connector - Duct to Duct	0.0	0.1	0.3
	8960317	Thermal Self Seal Connector - Duct to Fitting	0.0	0.1	0.3

220x90mm - Rectangular Ducting

plus Accessories and Terminals

220x90mm PVC	Product Code	Free Area = 18,545mm ²	Static Pressure Drop (in Pa)		
		Components	30l/s	60l/s	90l/s
	8960012	Rectangular Duct - 1.0m Long	0.3	1.2	2.7
	8960013	Rectangular Duct - 1.5m Long	0.4	1.7	3.8
	8960247	Rectangular Duct - 2m Long	0.5	2.3	4.4
	8960017	90° Bend - Horizontal	1.8	7.3	16.4
	8960019	45° Bend - Horizontal	0.6	2.4	5.4
	8960022	90° Bend - Vertical	1.6	6.2	14.0
	8960024	45° Bend - Vertical	0.5	1.9	4.3
	8960020	Tee Piece	n/a		
	8960014	Duct Connector	0.0	0.0	0.0
	8960270	Self-Seal - Duct Connector (Duct-to-Duct)	0.0	0.0	0.0
	8960271	Self-Seal - Duct Connector (Duct-to-Fitting)	0.0	0.0	0.0
	8960370	Rapid Self-Seal - Duct Connector Horizontal Self-Seal T-Piece	n/a		
	8960372	Rapid Self-Seal - Duct Connector 90° Bend Self-Seal	4.2	16.8	enq
	8960015	Fixing Bracket	n/a		
	8960025	220x90mm to Ø150mm Horizontal Adaptor	0.4	1.7	3.8
	8960021	220x90mm to 204x60mm Horizontal Adaptor	3.7	14.7	33.1
	8960016	220x90mm to Ø100mm Vertical Adaptor	n/a		
	8960018	220x90mm to Ø125mm Vertical Adaptor	5.8	23.0	51.8
	8960023	220x90mm to Ø150mm Vertical Adaptor	2.7	10.6	23.9
	Product Code	Terminations	30l/s	60l/s	90l/s
	8960011	Double Airbrick Adapter with Grilles (Free Area; 15,360mm ²) - White 	2.1	8.5	19.1
	8960008	Double Airbrick Adapter with Grilles (Free Area; 15,360mm ²) - Brown 			
	8960010	Double Airbrick Adapter with Grilles (Free Area; 15,360mm ²) - Terracotta 			
	8960009	Double Airbrick Adapter with Grilles (Free Area; 15,360mm ²) - Beige 			

220x90mm - Rectangular Ducting

plus Accessories and Terminals

220x90mm PVC	Product Code	Free Area = 18,545mm ²	Static Pressure Drop (in Pa)		
		Flexible PVC Duct	30l/s	60l/s	90l/s
	8960078	Rectangular – 3m length	n/a		
	Product Code	Fire Protection	30l/s	60l/s	90l/s
	QRS220/90	220x90mm Fire Sleeve (Fire Rating 120 mins)	n/a		
	QRS220/90SS	220x90mm Fire Slim Sleeve (Fire Rating 60 mins)	n/a		
	FSK220X90X132W	Intumescent Fire Wrap Kit - for partition walls up to 132mm (Fire Rating 60 mins)	n/a		
	Product Code	Attenuation	30l/s	60l/s	90l/s
	8960293	Hi-Flow Attenuator - 0.5m Long (Free Area; 11,664mm ²)	2.9	11.7	26.3
	8960294	Hi-Flow Attenuator - 1.0m Long (Free Area; 11,664mm ²)	3.5	13.8	31.0
	8960295	Hi-Flow Attenuator - 1.5m Long (Free Area; 11,664mm ²)	4.3	17.0	38.3
	Product Code	Insulation	30l/s	60l/s	90l/s
	89704	Insulation Jacket - 25mm Thick (10m Roll)	n/a		
	8960318	Rectangular Thermal Duct with connector - 1.0m Long	0.4	1.5	3.1
	8960319	Rectangular Thermal Duct with connector - 2.0m Long	0.9	3.2	6.8
	8960320	Thermal 90° Horizontal Bend with connectors	1.9	6.9	15.2
	8960321	Thermal 45° Horizontal Bend with connectors	0.5	2.1	4.8
	8960323	Thermal 90° Vertical Bend with connectors	1.7	6.4	14.2
	8960324	Thermal 45° Vertical Bend with connectors	0.2	1.0	2.3
	8960322	Thermal Tee Piece with connectors	n/a		
	8960334	Thermal 220x90mm to Ø125mm Plenum Adaptor	8.4	30.8	67.1
	8960325	Thermal Self Seal Connector - Duct to Duct	0.2	0.8	2.0
	8960326	Thermal Self Seal Connector - Duct to Fitting	0.2	0.8	2.0

Ceiling Diffuser Supply/ Extract (125mm)

For use with Titon's HRV Q Plus and CME Q Plus Ranges

Titon's residential valve is designed to be aesthetically pleasing and fit into any high specification property. It can be mounted onto a wall or ceiling and offers efficient airflow whilst maintaining a professional aesthetic design.

Quick and easy mounting by spring mechanism or mounting ring, to be fixed on both flexible and rigid ductwork. Provided with double lip seal (air tightness class D according EN 15727). Easy adjustment of volume damper. Standard finish RAL 9003, textured paint.

The ingenious architectural valve is suitable for homes as well as for offices. You can choose between a ceiling or a wall installation.

This product is not only pleasing to the eye, it combines also exceptional air technical performances at an extremely low noise level.

You can use this residential valve easily as supply or Extract, in new buildings and for renovation.

Valve



Features & Benefits

- Low sound levels
- Easy to install and adjust
- Minimal pressure loss
- Can be wall or ceiling mounted
- Sleek stylish design that gives your home a truly modern look

Drawing & Dimensions

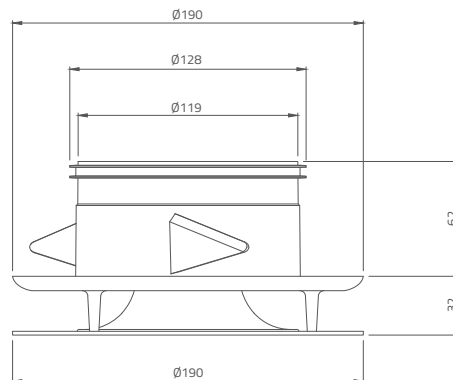

The residential diffuser consists of two parts:

- The base valve (available with mounting bracket or springs)
- The deflector plate (available in different shapes and surface finishing)

A simple screw joint couples both parts faultlessly. Each valve has a double lip seal to allow ductwork to achieve class D airtightness. Next to that a static pressure measurement can easily be done

Product Code	Size	Airflow	8l/s	15l/s	30l/s
9030001	125mm	Supply (open at 11mm)	4.5 pa	15 pa	60 pa
		Extract (open at 11mm)	5.6 pa	19 pa	76 pa

Product Code	Size	Type	Lw		
			25 dB(A)	30 dB(A)	35 dB(A)
9030001	125mm	Supply	24l/s	29l/s	35l/s
		Extract	24l/s	28l/s	34l/s

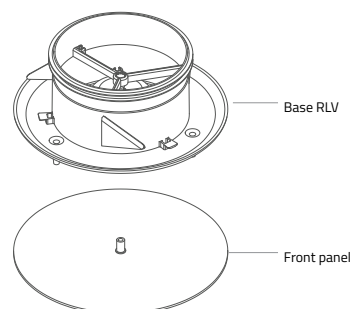

Dimensions in mm

Airflow

SUPPLY

SOUND POWER, PRESSURE DROP

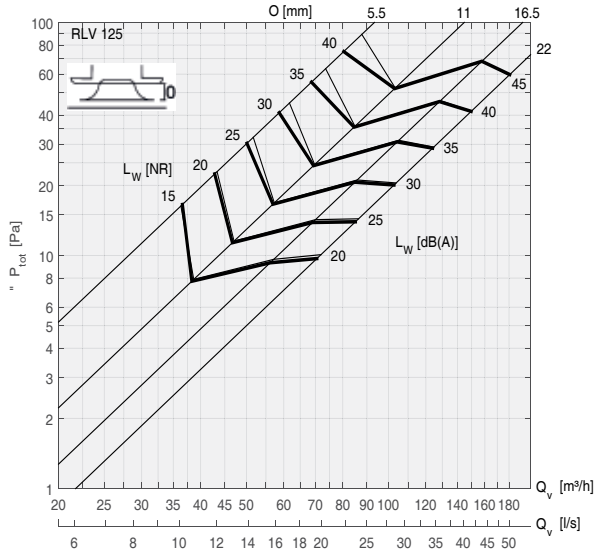

EXTRACT

SOUND POWER, PRESSURE DROP

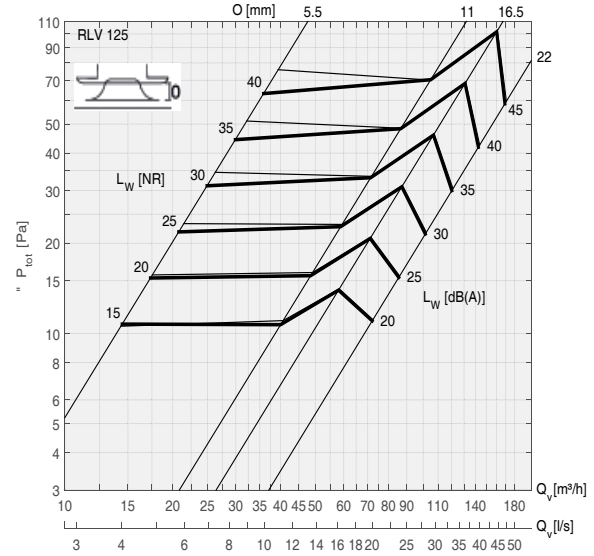

CRITICAL DISTANCE

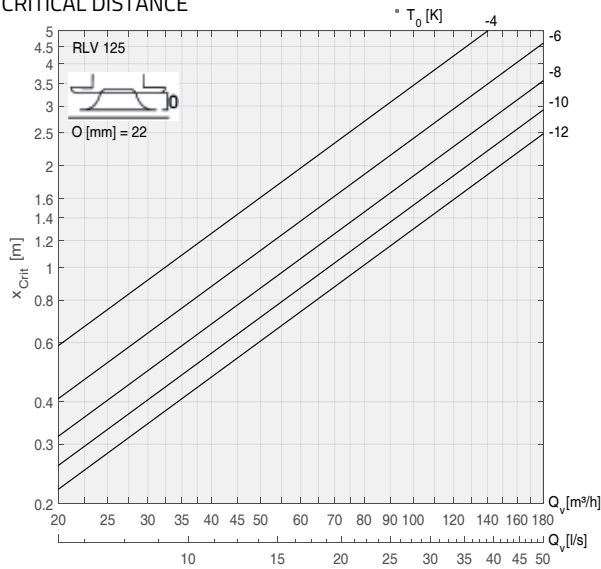

TEMPERATURE

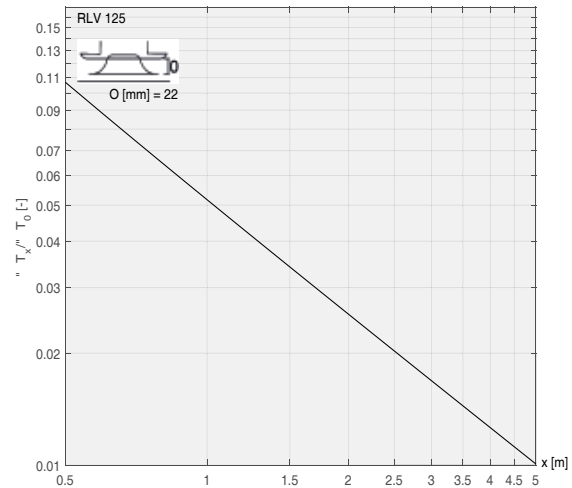

THROW

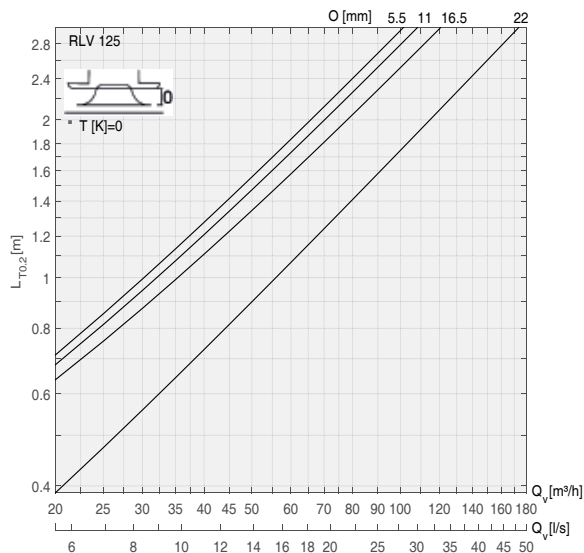

SELECTION EXAMPLE

Known data		
supply air flow rate, Q_v	[m³/h]	75
supply air temperature, T_0	[°C]	20
ambient temperature, T_a	[°C]	24
acoustic room attenuation, ΔL_r	[dB(A)]	8
max. air velocity in occupied zone	[m/s]	0,2
aperture, O	[mm]	22
Selection from graphs		
sound power, L_w	[dB(A)]	21
	[NR]	17
sound pressure, $L_p (= L_w - \Delta L_r)$	[dB(A)]	13
total pressure loss, ΔP_{tot}	[Pa]	11
throw, $L_{T0.2}$	[m]	1,3
critical distance @ $\Delta T_0 = T_a - T_0$, x_{crit}	[m]	2,5
temperature coefficient @ $L_{T0.2}$, $\Delta T_x / \Delta T_0$	[-]	0,038
temperature $T_x = T_a - (\Delta T_x / \Delta T_0)(T_a - T_0)$	[°C]	23,8

Ceiling Air Valve (Extract) - Standard

For use with Titon's HRV Q Plus and CME Q Plus Ranges

The round white metal ceiling air extract valve is manufactured from white epoxy powered coated steel. The valve has a male spigot to fit inside 100/125/150mm ducting.

The extract air valve is fully adjustable and has a locking nut to fix the position of the controlled disc upon commissioning.

The valve is supplied complete with a fixing body with pre-drilled holes for installation.

The valve engages/disengages to the fixing body by a quarter turn clockwise/anticlockwise.

Product Specification

Ceiling Metal Vent Diffuser – Extract			
Part Number	8960227	8960230	8960234
Size	100mm	125mm	150mm
Colour	RAL9016	RAL9016	RAL9016
Operating Temperature			
Max	+60°C	+100°C	+60°C
Min	-15°C	-20°C	-15°C
Weight	270g	343g	270g

Drawing and Dimensions

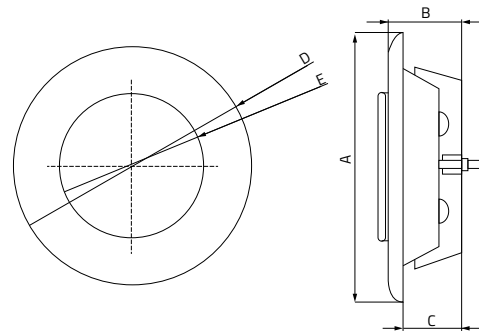

	100mm	125mm	150mm
ØA	138	163	201
B	40	44	51
C	32	36	38.5
ØD	138	163	202
ØE	74	98.3	119

Dimensions in mm

Performance Details

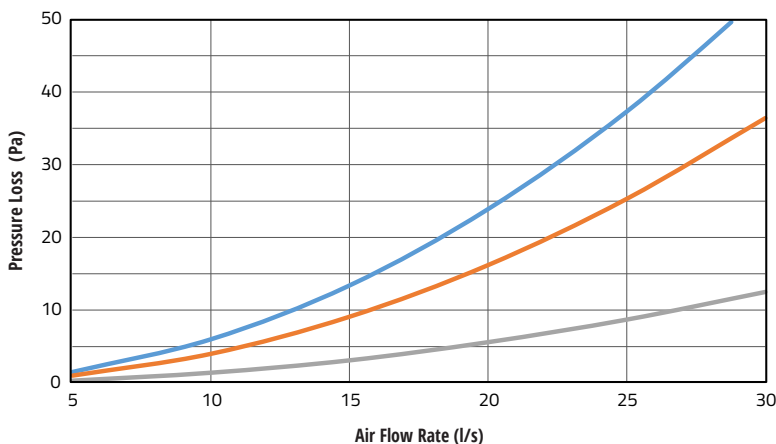

— 100mm
— 125mm
— 150mm

Airflow l/s	100mm (Pa)	125mm (Pa)	150mm (Pa)
8	5	6	2
13	10	10	3
21	23	20	6
30	54	36	13
60	228	132	50
120	935	430	195

Pressure loss with control disc open to 10mm

Ceiling Air Valve (Supply) - Standard

For use with Titon's HRV Q Plus Range

The round white metal ceiling air supply valve is manufactured from white epoxy powered coated steel. The valve has a male spigot to fit inside 100/125/150mm ducting.

The supply air valve is fully adjustable and has a locking nut to fix the position of the controlled disc upon commissioning.

The valve is supplied complete with a fixing body with pre-drilled holes for installation.

The valve engages/disengages to the fixing body by a quarter turn clockwise/anticlockwise.

Product Specification

Ceiling Metal Vent Diffuser – Supply			
Part Number	8960229	8960232	8960235
Size	100mm	125mm	150mm
Colour	RAL9016	RAL9016	RAL9016
Operating Temperature			
Max	+60°C	+100°C	+60°C
Min	-15°C	-20°C	-15°C
Weight	270g	343g	270g

Drawing and Dimensions

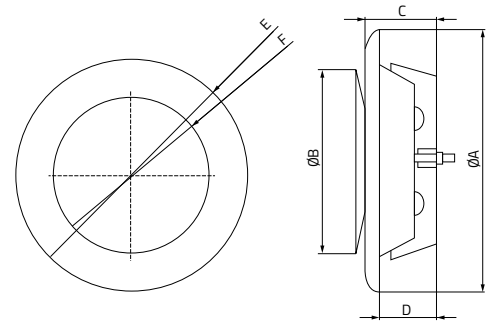

	100mm	125mm	150mm
ØA	138	162	201
ØB	94	114	135
C	40	44	51
D	32	36	38.5
ØE	138	163	202
ØF	94	114	135

Dimensions in mm

Performance Details

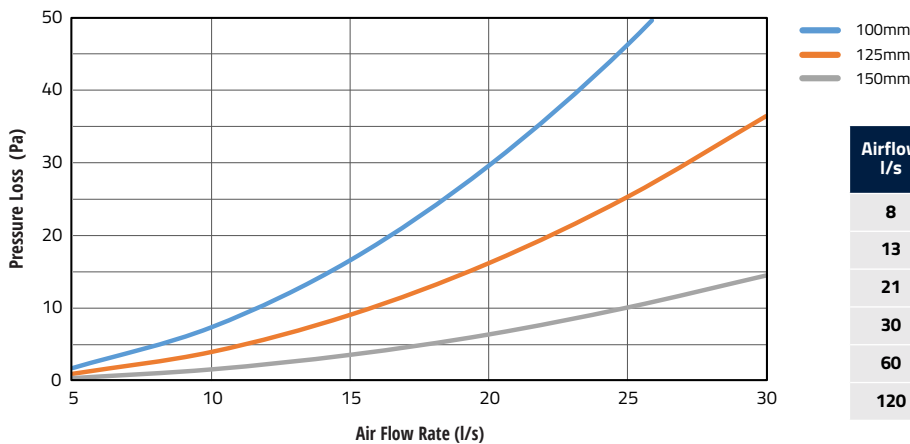

Pressure loss with control disc open to 10mm

Airflow l/s	100mm (Pa)	125mm (Pa)	150mm (Pa)
8	6	6	2
13	12	10	3
21	33	20	7
30	67	36	15
60	280	132	57
120	1150	430	227

Ceiling Air Valve (Extract) - Fire Rated

For use with Titon's HRV Q Plus and CME Q Plus Ranges

The fire rated air valve is manufactured from white epoxy coated powder coated steel. The valve has a male spigot to fit inside a ducting 100/125/150 system depending on selection.

The extract air valve is fully adjustable and has a locking nut to fix the position of the control disc upon commissioning. It is supplied complete with fixing body and pre-drilled holes for installation.

The Fire Rated air valve incorporates an integral intumescent material and has been fire tested to BS EN 1365-2:2014 with 60 minutes rating for ceilings.

The valve engages/disengages to the fixing body by a quarter turn clockwise/anticlockwise.

Fire Valve



Product Specification

Ceiling Metal Vent Diffuser – Extract			
Part Number	8960228	8960231	8960274
Size	100mm	125mm	150mm
Colour	RAL9016	RAL9016	RAL9016
Operating Temperature			
Max	+60°C	+60°C	+60°C
Min	-15°C	-15°C	-15°C
Weight	272g	390g	510g

Drawing and Dimensions

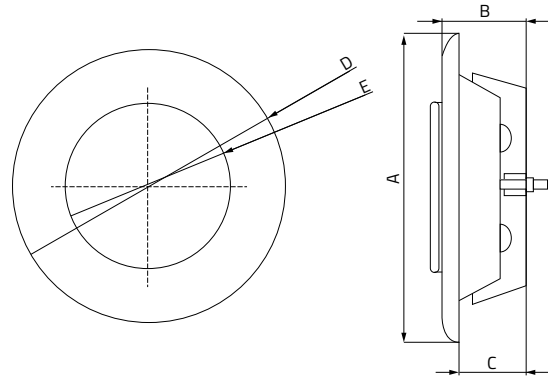

	100mm	125mm	150mm
ØA	138	163	201
B	40	44	51
C	32	36	38.5
ØD	138	163	202
ØE	74	98.3	119

Dimensions in mm

Performance Details

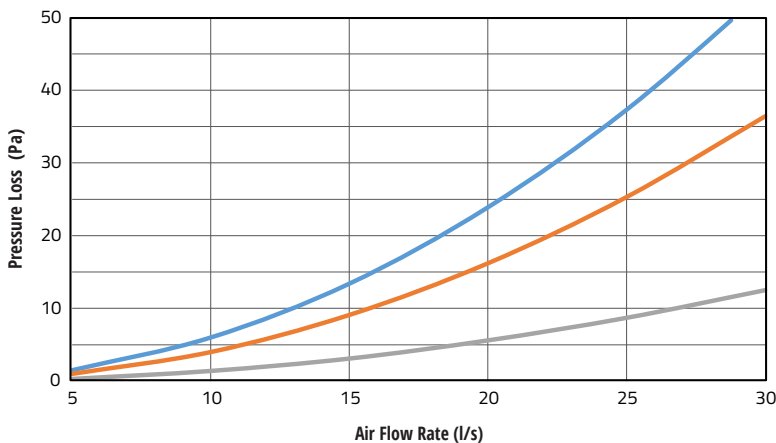

— 100mm
— 125mm
— 150mm

Airflow l/s	100mm (Pa)	125mm (Pa)	150mm (Pa)
8	5	6	2
13	10	10	3
21	23	20	6
30	54	36	13
60	228	132	50
120	935	430	195

Pressure loss with control disc open to 10mm

Ceiling Air Valve (Supply) - Fire Rated

For use with Titon's HRV Q Plus Range

The fire rated air valve is manufactured from white epoxy coated powder coated steel. The valve has a male spigot to fit inside a ducting 100/125/150 system depending on selection.

The extract air valve is fully adjustable and has a locking nut to fix the position of the control disc upon commissioning. It is supplied complete with fixing body and pre-drilled holes for installation.

The Fire Rated air valve incorporates an integral intumescent material and has been fire tested to BS EN 1365-2:2014 with 60 minutes rating for ceilings.

The valve engages/disengages to the fixing body by a quarter turn clockwise/anticlockwise.

Product Specification

Ceiling Metal Vent Diffuser – Supply			
Part Number	8960276	8960233	8960275
Size	100mm	125mm	150mm
Colour	RAL9016	RAL9016	RAL9016
Operating Temperature			
Max	+60°C	+100°C	+60°C
Min	-15°C	-20°C	-15°C
Weight	272g	334g	510g

Drawing and Dimensions

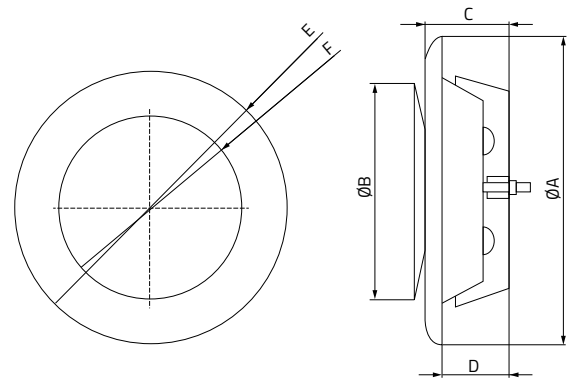

	100mm	125mm	150mm
ØA	138	162	201
ØB	94	114	135
C	40	44	51
D	32	36	38.5
ØE	138	163	202
ØF	94	114	135

Dimensions in mm

Fire Valve



Performance Details

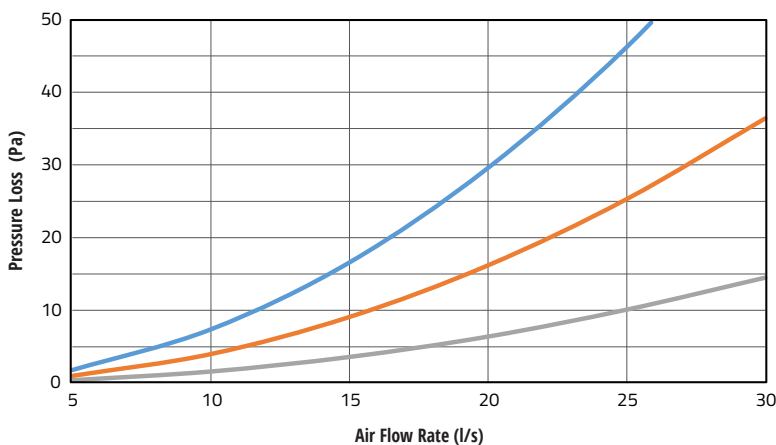

— 100mm
— 125mm
— 150mm

Airflow l/s	100mm (Pa)	125mm (Pa)	150mm (Pa)
8	6	6	2
13	12	10	3
21	33	20	7
30	67	36	15
60	280	132	57
120	1150	430	227

Pressure loss with control disc open to 10mm

Semi-rigid Ducting

For use with Titon's HRV Q Plus and CME Q Plus Ranges

Titon can supply semi-rigid ducting suitable for domestic ventilation applications. This is not widely used in the UK, however, it is clear semi-rigid ducting can offer a number of benefits over the traditional rigid product:

Easier to fit - via 'dry' joints which seal tightly and do not require sealant and tape.

In addition, ducting is supplied in long lengths, which means usually only two cuts and two joints are required for each duct run to a room. This drastically reduces the number of different duct items required. This can result in a much quicker and cheaper installation than conventional methods.

Easier to commission - Central flow plenums reduce the need to re-adjust flow around the dwellings and flow terminals do not need to be adjustable.

Improved performance - Flow is smooth, while leaks and restrictions are eliminated, so lower settings on the unit can be utilised. A better installed system should also develop fewer problems in the future.

Semi-rigid



Features & Benefits

- Flow rates are set easily and simply at install, no need for additional commissioning
- Components click together to form airtight secure joints without using messy sealants and unreliable tapes
- Joints can be disassembled and reassembled easily to allow installer adjustment
- Minimal resistance to airflow, due to smooth inner skin
- Ducting remains flexible whilst maintaining profile – the bends do not collapse which is a risk with traditional flexible ducting
- The duct is cut to length on-site meaning no modular connection is required between plenum and air valve
- Successfully used for many years on the continent. Titon have adapted the product specifically to suit installation in new build dwellings in the UK
- Individual rooms connected to sound absorbing plenum to help overcome noise transfer, reducing the risk of noise pollution from outside the dwelling whilst eliminating 'cross talk' between rooms

There are considerations to be made in order to achieve these advantages - however, with forethought these can be incorporated to allow a semi-rigid ducted system to be used:

Design ahead - Some extra room is required near the ventilation unit for the inclusion of the plenum boxes, so this has to be discussed at the point of house design.

Duct runs - As each room is ducted separately, which helps control specific airflow, duct layout and provision for it must be planned.

Familiarity for contractors - It will take one or two installations before contractors become used to the system and can then reap the benefits of its simplicity.

Cost - The system parts are typically more expensive per property than rigid ducting, however savings can be made due to the reduced labour cost in installing each system.

Semi-Rigid Components

	Product Code	Product Description		Product Code	ø92mm	Product Code		Product Code	ø75mm
	DSR122	Insulated 8 port manifold		DSR008	Semi-Rigid ducting - Blue	DSR052		DSR052	Semi-Rigid ducting - Red
	DSR007	Restriction ring		DSR004	Manifold to duct connector	DSR050		DSR050	Manifold to duct connector
	DSR022	Universal diffuser (Extract & Supply)		DSR010	Duct to duct connector	DSR049		DSR049	Duct to duct connector
				DSR013	Duct to diffuser straight connector	DSR077		DSR077	Duct to diffuser straight connector
				DSR016	90° bend	DSR078		DSR078	90° bend
				89706	Insulation sleeve x 10m	89707		89707	Insulation sleeve x 10m
				DSR126	Duct to diffuser 90° connector	DSR125		DSR125	Duct to diffuser 90° connector

Thermal Ducting

For use with Titon's HRV Q Plus and CME Q Plus Ranges

Lightweight, durable and fully conformed to building regulations, the Self-Seal Thermal Ducting range is designed to assist in minimising heat loss through the ductwork system of your chosen ventilation system while preventing condensation forming in or on the duct. The first of its kind to introduce push-fit technology, our range is supplied complete, with no need for extra connections or components.

The Self-Seal Thermal range includes both round and rectangular solutions and can therefore provide everything you need for a full installation.

Features & Benefits

- Easy to install with a simple pushfit
- Minimises air leakage
- Installer friendly
- Profiles to suit any application
- Energy saving
- Building Regulation compliant
- No need for extra Rockwood or foil wrapping
- No requirement for additional clamping

Push

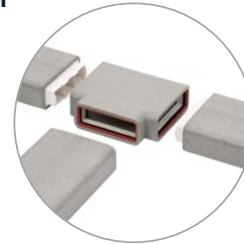

Lock

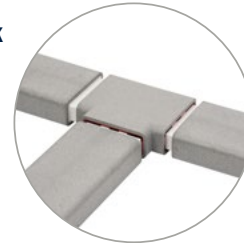

Click



Thermal

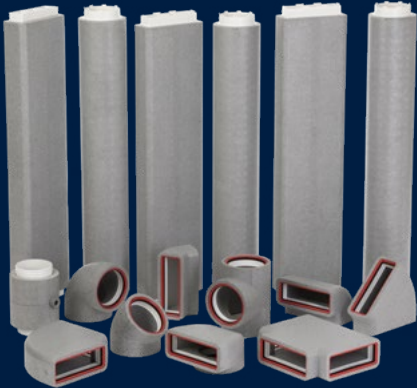

Thermal Ducting Components

	Product Code		Insulation
	Ø125mm	Ø160mm	
	8960299	8960327	Round Thermal Duct with connector - 1.0m Long
	8960300	8960328	Round Thermal Duct with connector - 2.0m Long
	8960303	8960329	Thermal 90° Bend with connectors
	8960304	8960330	Thermal 45° Bend with connectors
	8960305	8960331	Thermal Tee Piece with connectors
	-	8960335	Thermal - Ø160mm to Ø150mm Adaptor
	8960306	8960332	Thermal Self Seal Connector - Duct to Duct
	8960307	8960333	Thermal Self Seal Connector - Duct to Fitting

	Product Code		Insulation
	204x60mm	220x90mm	
	8960308	8960318	Rectangular Thermal Duct with connector - 1.0m Long
	8960309	8960319	Rectangular Thermal Duct with connector - 2.0m Long
	8960310	8960320	Thermal 90° Horizontal Bend with connectors
	8960311	8960321	Thermal 45° Horizontal Bend with connectors
	8960313	8960323	Thermal 90° Vertical Bend with connectors
	8960314	8960324	Thermal 45° Vertical Bend with connectors
	8960312	8960322	Thermal Tee Piece with connectors
	8960315	ENQ	Thermal 204x60mm to Ø125mm Plenum Adaptor
	8960316	8960325	Thermal Self Seal Connector - Duct to Duct
	8960317	8960326	Thermal Self Seal Connector - Duct to Fitting

Sound Attenuators - Semi Flexible

For use with Titon's HRV Q Plus Range

Titon's Semi Flexible Sound Attenuators consists of a strong multiple layered corrugated perforated aluminium inner duct with an aluminium/polyester laminated outer jacket.

The space between the inner and outer duct is filled with 25mm sound absorbing material which is protected by a vapor barrier. The duct is fitted with galvanised metal sleeves at both ends to fit to duct work - Female spigots for direct connection to MVHR's or duct connectors.

Our Semi Flexible Sound Attenuators fulfil all the requirements and are classified as specified within EN 13180: Ventilation for buildings – Duct work - Dimensions and mechanical requirements for flexible ducts.

Silencer



Features & Benefits

- High-flow performance and low resistance
- Reducing in-duct noise
- Reduces cross talk attenuation
- Available in 204 x 60mm and 220 x 90mm
- Lengths available 500mm, 1000mm and 1500mm
- Lightweight and easy to install
- Anti-corrosive

Specification

Product Code	Product Type
89720	125mm ø Flexible Silencer 0.5m length F-F
89721	125mm ø Flexible Silencer 1m length F-F
89722	150mm ø Flexible Silencer 0.5m length F-F
89723	150mm ø Flexible Silencer 1m length F-F
89725	200mm ø Flexible Silencer 1m length F-F
89728	200mm ø Flexible Silencer 1m length F-F

Temperature range:

Inner duct: -30°C to 250°C

Outer jacket: -30°C to 140°C

Operating pressure: up to +2000 Pa

Operating air velocity: max. 10 m/s

Min. bending radius: 1 x Ø + 25 mm

Standard length: 0.5 & 1.0 metres

Other diameters available to order.

Construction

Inner duct: Aluminium

Barrier: Nonwoven cloth

Glass wool blanket: 25mm, 16kg/m³

Outer jacket: Alu/poly laminate

R-value glass wool: 0.65 m² K/W

Thermal Conductivity: 0.0385w/(m.k)

Appearance: Aluminium

Classification

EU (EN 13501-1):

Inner duct: A1

Outer Jacket: B-s1,d0 mode

Drawing and Dimensions

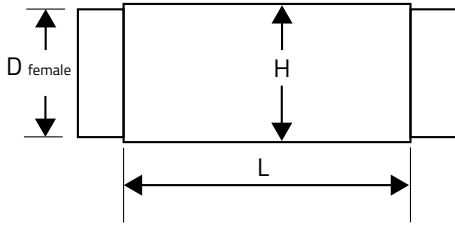

According to EN-1506		
D _{nom} (mm)	D _{female} (mm)	Tol.
125	125.5	+0; -0.5
150	150.6	+0; -0.6
200	200.7	+0; -0.7

Sound Attenuation

Length 500mm

Dn (mm)	H (mm)	L (mm)	L Compressed (mm)	Attenuation, dB - Mid-frequency, Hz							
				63	125	250	500	1000	2000	4000	8000
125	175	500	390	6.3	7.1	15.2	19.9	20.3	26.1	17.1	12.9
150	200	500	390	8.3	9.3	17.8	19.4	16.7	25	19.8	13.8
200	250	500	390	9.2	10	17.3	14.3	12.9	15.8	12	8.2



Length 1000mm

Dn (mm)	H (mm)	L (mm)	L Compressed (mm)	Attenuation, dB - Mid-frequency, Hz							
				63	125	250	500	1000	2000	4000	8000
125	175	1000	580	12.4	20.1	33.6	29.8	29.5	33.6	32.1	23.6
150	200	1000	580	11.1	11.8	34.2	28.5	26.3	34.9	27.2	21.8
200	250	1000	580	11.1	14.6	29.5	20.7	21	30	17.7	13.2



Attenuation Through The Duct Wall (Breakout) - Length 500mm

Dn (mm)	H (mm)	L (mm)	L Compressed (mm)	Attenuation, dB - Mid-frequency, Hz							
				63	125	250	500	1000	2000	4000	8000
125	175	500	390	25.3	22.5	17.2	11.9	11.2	11.5	13	18
150	200	500	390	24.8	19.6	14.2	9.6	8.9	10.3	12.6	18.1
200	250	500	390	22.8	17.2	11.9	8	7.2	6.9	9.5	13.7

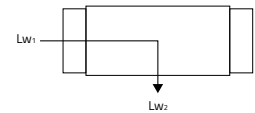

Attenuation Through The Duct Wall (Breakout) - Length 1000mm

Dn (mm)	H (mm)	L (mm)	L Compressed (mm)	Attenuation, dB - Mid-frequency, Hz							
				63	125	250	500	1000	2000	4000	8000
125	175	1000	580	25.2	21.6	18.7	13.2	12.2	12.5	14	17.5
150	200	1000	580	23.9	19.4	12.7	9	8	9.1	11.6	14.6
200	250	1000	580	21.8	17.8	12.9	9.3	8.4	8	10.5	13.9

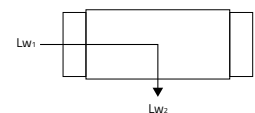

Pressure Loss

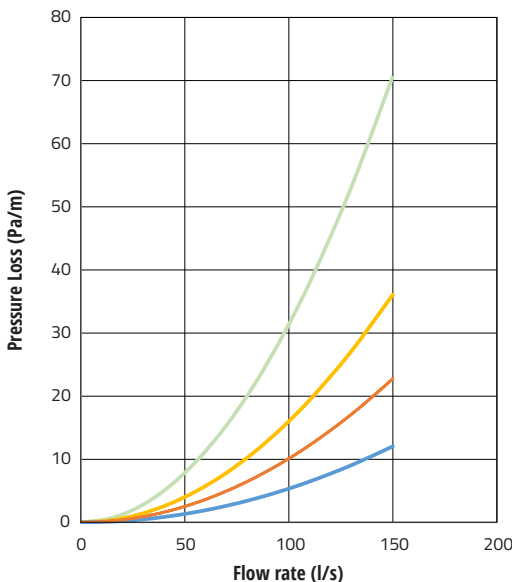

Sound Attenuators - Rigid Ducting

For use with Titon's HRV Q Plus and CME Q Plus Ranges

In the ever changing world of greater energy efficiency and more comfortable living, there has been a step change in the way that designers and specifiers have addressed domestic ventilation challenges.

Many new homes now incorporate central ventilation systems whereupon individual rooms are connected to a central system utilising a heat recovery unit. This allows for the collection of warm moist air from the wet areas, say in the kitchen and bathroom, to be ducted to the central heat recovery unit, where the moisture content is reduced and the dryer, warm air is used to condition fresh air from outside which is returned to other living spaces, such as the lounge and bedrooms.

One of the potential disadvantages to this network of ducting is that noise from the electric fan and mechanical moving parts can be transmitted along the duct runs and cause a noise nuisance to the occupants.

Silencer

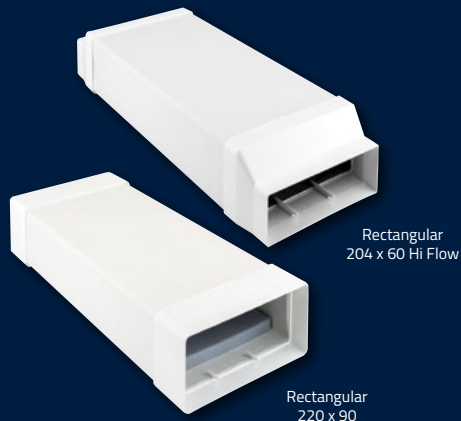

Features & Benefits

- High-flow performance and low resistance
- Reducing in-duct noise
- Reduces cross talk attenuation
- Available in 204 x 60mm and 220 x 90mm
- Lengths available 500mm, 1000mm and 1500mm
- Lightweight and easy to install
- Anti-corrosive

Key Features

Titon's plastic duct silencers available in 204mm x 60mm and 220mm x 90mm have been designed for high flow rate installations with low pressure drops.

The new silencer offers many advantages over the traditional metal equivalent with corrosion free plastic construction giving a long serviceable life and no maintenance.

With a height profile of only 95mm, allows for installation in most ceiling and roof voids and can be hidden out of sight on top of kitchen cupboards.

Titon's plastic duct silencers provide effective attenuation as recommended by Document F of the Building Regulations 2010.

Specification

Available Colours	White
Free Area	up to 11,664mm ²
Max/min temp	60°C / -15°C
Material used	UPVC

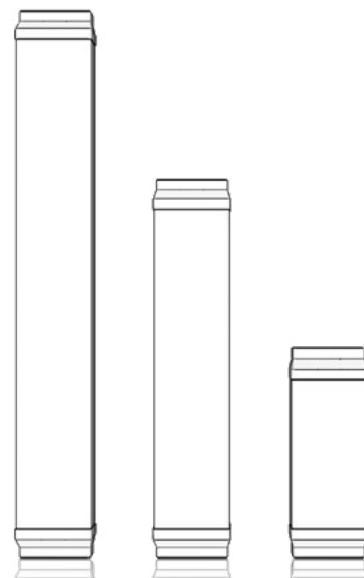
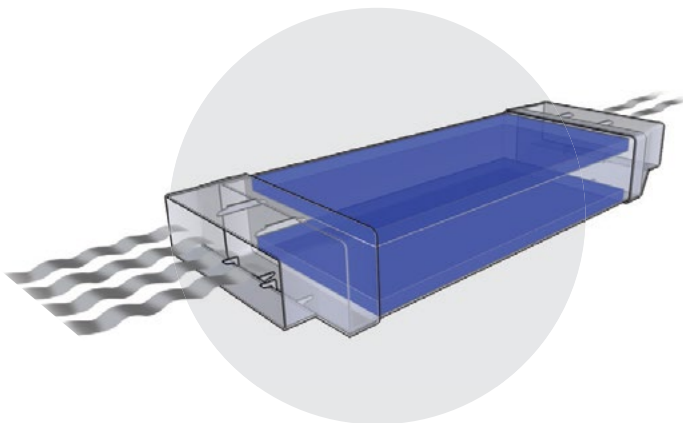

1500mm 1000mm 500mm

Drawing and Dimensions

Rectangular 204 x 60 - Hi Flow

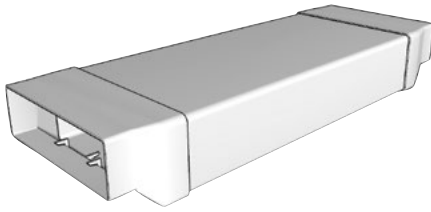

Product Code	Description	Width	Height	Length
8960290	Rectangular 204 x 60 - Hi Flow	225	95	560
8960291	Rectangular 204 x 60 - Hi Flow	225	95	1060
8960292	Rectangular 204 x 60 - Hi Flow	225	95	1560

Rectangular 220 x 90

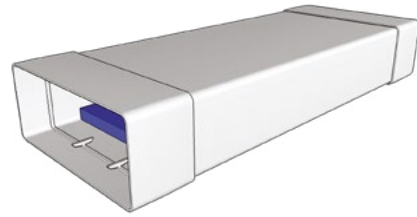

Product Code	Description	Width	Height	Length
8960293	Rectangular 220 x 90	225	95	508
8960294	Rectangular 220 x 90	225	95	1008
8960295	Rectangular 220 x 90	225	95	1508

Sound Attenuation Chart (dB)

Rectangular 204 x 60 - Hi Flow

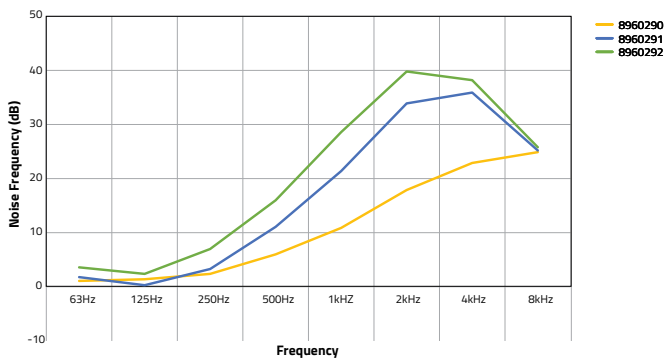

Product Code	63Hz	125Hz	250Hz	500Hz	1kHz	2kHz	4kHz	8kHz
8960290	1.1	1.4	2.4	6.0	10.9	17.9	22.9	24.9
8960291	1.8	0.3	3.3	11.1	21.4	33.9	35.9	25.2
8960292	3.6	2.4	7.0	16.0	28.6	39.8	38.2	25.8

Rectangular 220 x 90

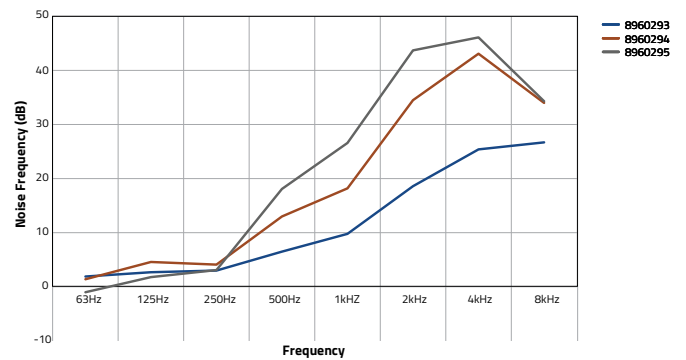

Product Code	63Hz	125Hz	250Hz	500Hz	1kHz	2kHz	4kHz	8kHz
8960293	1.9	2.7	3.0	6.5	9.8	18.6	25.4	26.7
8960294	1.4	4.6	4.1	13.0	18.2	34.5	43.1	34.0
8960295	-1	1.8	3.1	18.1	26.6	43.7	46.1	34.3

Product Code	(l/s) Flow rate	15	30	60	90	120	150	180
8960290	Pa	1.5	7.8	28.0	59.0	102.0	153.0	214.0
8960291	Pa	1.8	8.0	27.8	85.0	104.0	166.0	240.0
8960292	Pa	2.0	9.3	28.0	60.0	102.0	155.0	214.0

Product Code	(l/s) Flow rate	15	30	60	90	120	150	180
8960293	Pa	0.9	3.7	11.7	25.5	45.5	71.0	101.5
8960294	Pa	1.5	3.9	13.8	30.0	53.4	82.5	118.0
8960295	Pa	1.5	4.8	17.0	37.0	64.0	99.0	140.0

Q Plus High Flow Brick - Plastic

For use with Titon's HRV Q Plus and CME Q Plus Ranges

The Q Plus High Flow Brick is a unique design, as the exceptional airflow performance of a single unit makes it ideal for use in ducted domestic ventilation systems, replacing conventional and unsightly airbricks at least twice the size.

A cost effective alternative recommended for use with Titon Q Plus Best Practice MVHR and CME products, the Q Plus High Flow Air Brick is designed to be built into the brickwork during construction. It can be supplied with the appropriate ducting components to bridge the cavity, making it easy to connect to the ventilation system once installed.

Features & Benefits

- Unique high flow design equivalent to many brick sized grilles
- Cost effective; lower cost than double brick grille and adaptor
- Recommended for use with EST Best Practice systems (Titon Q Plus)
- Saves time and complication of creating double brick size aperture
- Designed to be an integral part of external walls
- Q Plus High Flow Brick AAO = 8670mm²
- Q Plus High Flow Brick EA = 10602mm²
- Can be supplied with short duct length for build in during construction, creating an unobstructed air path

Air Brick



RAL 8004 - Terracotta



RAL 1001 - Sand



RAL 7012 - Grey



RAL 9010 - White



RAL 8017 - Brown

Description

Q Plus High Flow Air Brick

Product Codes

TA350/010 - Grey Air Brick

TA350/093 - Beige Air Brick

TA350/094 - Terracotta Air Brick

TA350/315 - Brown Air Brick

TA350/932 - White Air Brick

TA356/xxx* - Bezel for TA350 Q Plus High Flow Brick
Plastic

*xxx confirm colour from codes given in TA350

Specification

Dimensions:

64.5mm height x 213.5mm width x 58mm depth

Weight: Approx 100g

Finishes: Terracotta, Sand, Brown, White or Grey

Bezel: TA356, White, Grey or Brown

Materials: 20% talc filled polypropylene
(UV Stabilised)

Installation: Install in accordance with Residential
Ventilation Association Good Practice recommendations
- details on request.

Maintenance: Wipe with a damp cloth and remove any
blockages on a regular basis.

Drawing & Dimensions

Air Brick

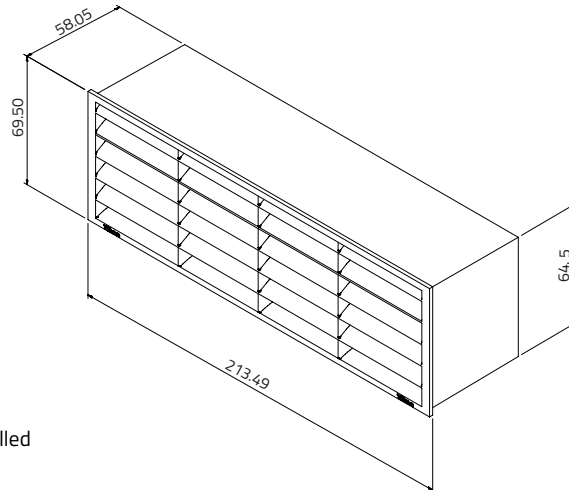

Bezelled

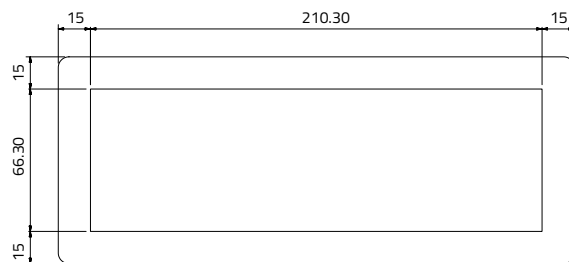

High Flow Terminal Resistance (supply or extract)

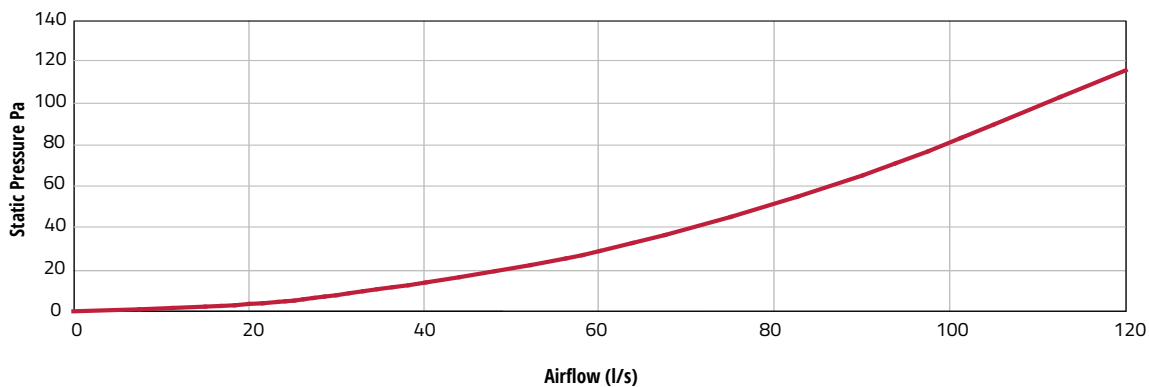

Titon FireSafe® - Single Air Brick

For use with Titon's HRV Q Plus and CME Q Plus Ranges

The new Titon FireSafe® Air Brick Range is a unique high flow terminal designed for powered ventilation systems offering low resistance to airflow, but high resistance to fire as set out in Approved Document B (fire safety) volume 1: Dwellings, 2019 edition. Constructed from sheet steel (A1) and polyester powder coated to classification A2-s1, d0.

The Titon FireSafe® Air Brick is designed to be built into external wall types during construction. The range consists of short and long versions and can easily be connected to both 204x60 and 220x90 rectangular ducting.

Description

Titon FireSafe® Single Air Brick



FireSafe



Product Codes

- TA360** - Titon FireSafe® Air Brick 204x60x100
- TA361** - Titon FireSafe® Air Brick 204x60x100 Bezelled
- TA370** - Titon FireSafe® Air Brick 204x60x400
- TA371** - Titon FireSafe® Air Brick 204x60x400 Bezelled
- TA380** - Titon FireSafe® Air Brick 330x60x100
- TA381** - Titon FireSafe® Air Brick 330x60x100 Bezelled
- TA390** - Titon FireSafe® Air Brick 330x60x400
- TA391** - Titon FireSafe® Air Brick 330x60x400 Bezelled
- TA392** - Titon FireSafe® Air Brick 330x60x500
- TA393** - Titon FireSafe® Air Brick 330x60x500 Bezelled

Accessories

- TA362** - Metal 45° Bend 204x60
- TA382** - Metal 45° Bend 330x60
- TA383** - Metal Transition 330x60 to 220x90
- TA385** - Metal Transition 330x60 to 220x90 Flat Top Profile
- TA363** - Metal Sleeve 204x60x200
- TA384** - Metal Sleeve 220x90x400

Features & Benefits

- Polyester Powder Coating meeting EN13501-1 classification A2-s1,d0
- Material 1mm Electrogalvanized Sheet Steel, fire class A1 'no contribution to fire'
- Equivalent to many brick sized grilles and additional brick and half size option
- Designed for both 204x60 & 220x90 ducting
- Bezelled version for use with exterior cladding instead of brickwork
- Complies with the latest standard as set out in Approved Document B (fire safety) volume 1: Dwellings, 2019 edition
- High flow terminal designed for powered ventilation systems offering low resistance to airflow and high resistance to fire
- Extensive versatile range for different installation options
- Registered Design
- Also available in Double brick (204x128) option
- Special paint finishes available depending on quantity
- Performance tested to BS EN13141-2:2010
- Corrosion resistance - salt spray tested to BS EN ISO 9227:2012
- Optional lengths available at request
- Compatible with thermal and rigid ducting

Specification

Materials:

Steel Electrolytically Zinc Coated (BS EN 10152 DC01 ZE25/25)

Paint:

Powder Coated (A2-s1, d0 classification to EN 13501-1)

Registered Design

- TA360** - Registered Design No 6067647
- TA370** - Registered Design No 6067645
- TA380** - Registered Design No 6067648
- TA390** - Registered Design No 6067646
- TA392** - Registered Design No 6067646

Finishes: Terracotta, Sand, Grey, White or Brown

Colour Reference (add to end of part number)

- /023 - Brown (Semigloss RAL 8017)
- /086 - Terracotta (Matt RAL 8004)
- /151 - White (Matt RAL 9010)
- /397 - Grey (Matt RAL 7012)
- /626 - Sand (Matt RAL 1001)

Installation:

Install in accordance with Residential Ventilation Association Good Practice recommendations – details on request.

Maintenance: Wipe with a damp cloth and remove any blockages on a regular basis.

Free Area:

Small Air Bricks

TA360, TA361, TA370 & TA371

Titon FireSafe® Air Brick AAO = 10089 mm²

Large Air Bricks

TA380, TA381, TA390, TA391, TA392 & TA393

Titon FireSafe® Air Brick AAO = 16060 mm²

High Flow Terminal Resistance - 204x60x100/400

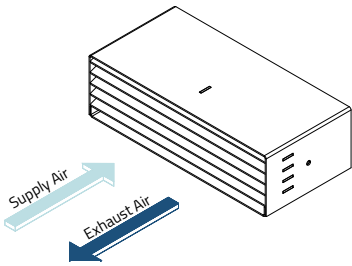

TA360 - Titon FireSafe® Air Brick 204x60x100/
TA361 - Titon FireSafe® Air Brick 204x60x100 Bezelled

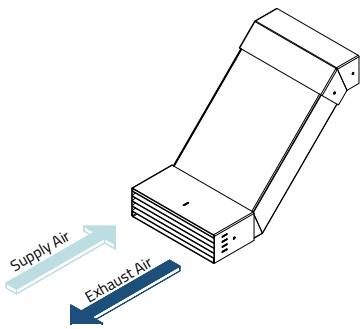
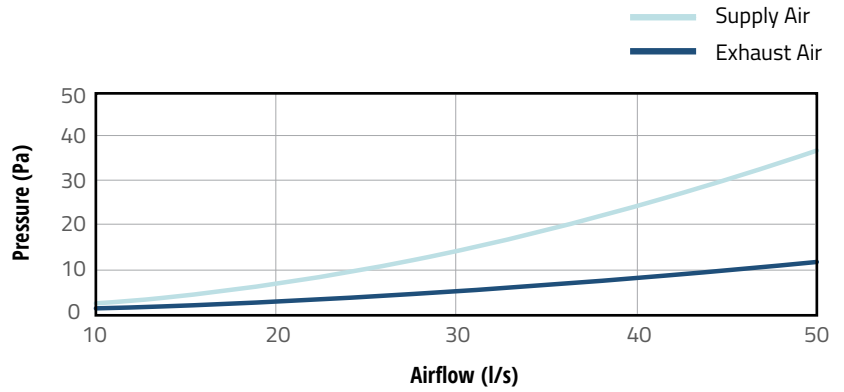

TA360 - Titon FireSafe® Air Brick 204x60x100/
TA361 - Titon FireSafe® Air Brick 204x60x100 Bezelled with **TA362** - Titon FireSafe® Air Brick 45° Bend 204x60
 *Resistance curve - air brick and accessory combined.

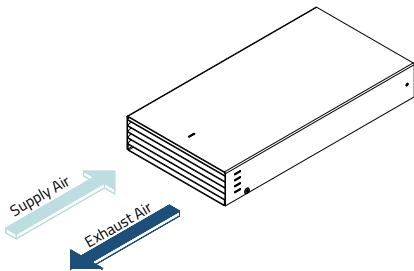
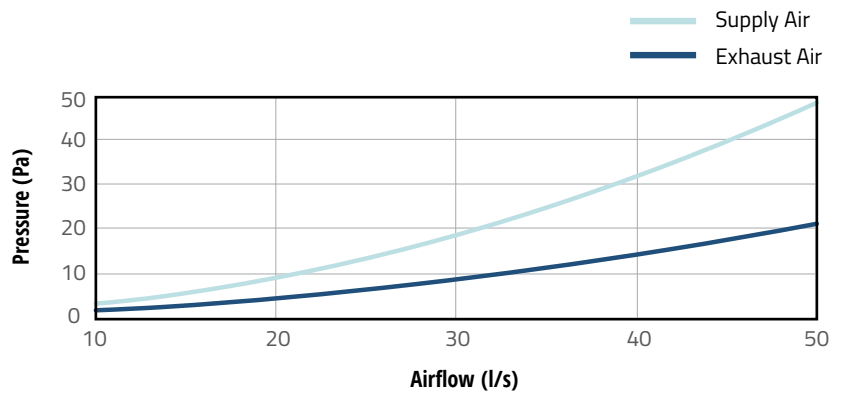

TA370 - Titon FireSafe® Air Brick 204x60x400/
TA371 - Titon FireSafe® Air Brick 204x60x400 Bezelled

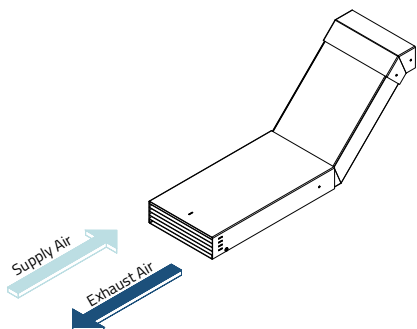
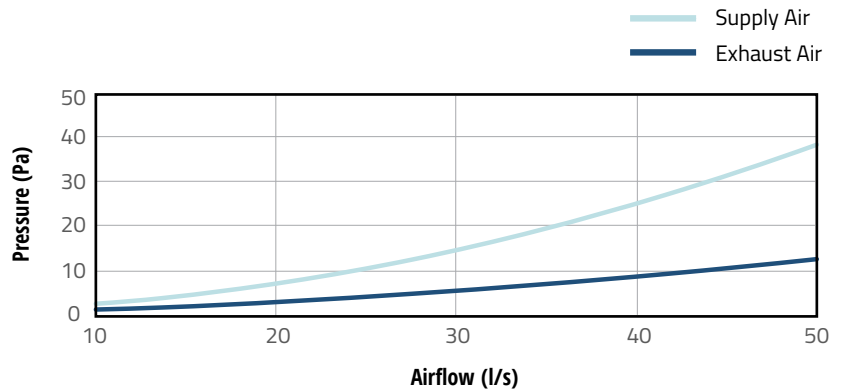

TA370 - Titon FireSafe® Air Brick 204x60x400/
TA371 - Titon FireSafe® Air Brick 204x60x400 Bezelled with **TA362** - Titon FireSafe® Air Brick 45° Bend 204x60
 *Resistance curve - air brick and accessory combined.

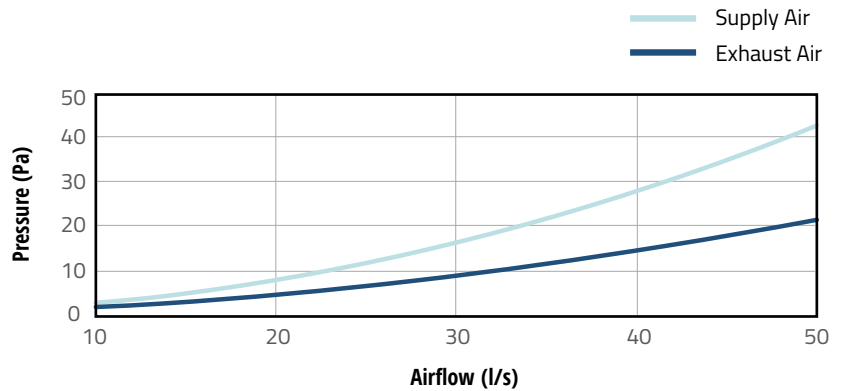

High Flow Terminal Resistance - 330x60x100/400/500

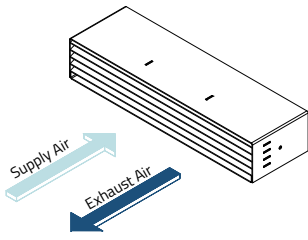

TA380 - Titon FireSafe® Air Brick 330x60x100/
TA381 - Titon FireSafe® Air Brick 330x60x100 Bezelled

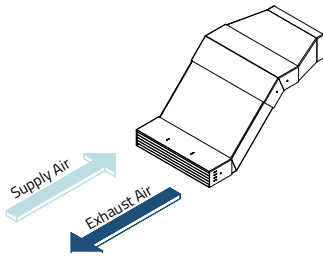
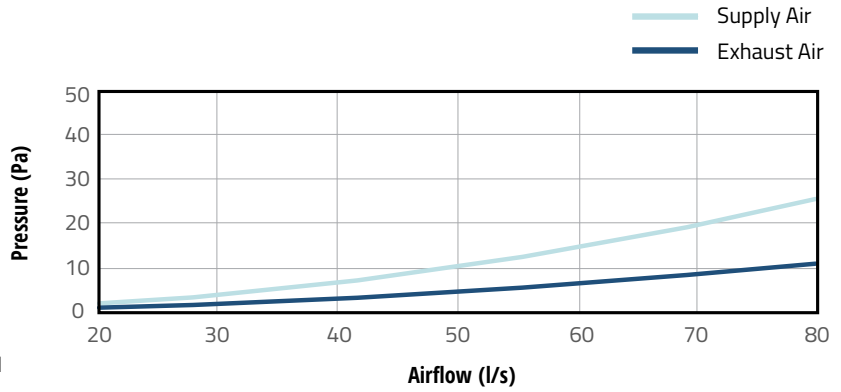

TA380 - Titon FireSafe® Air Brick 330x60x100/
TA381 - Titon FireSafe® Air Brick 330x60x100 Bezelled with **TA382** - 45° Bend 330x60 and **TA383** - Transition 330x60 to 220x90
TA385 - Transition 330x60 to 220x90 Flat Top Profile
 *Resistance curve - air brick and accessory combined.

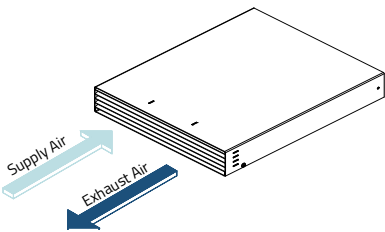
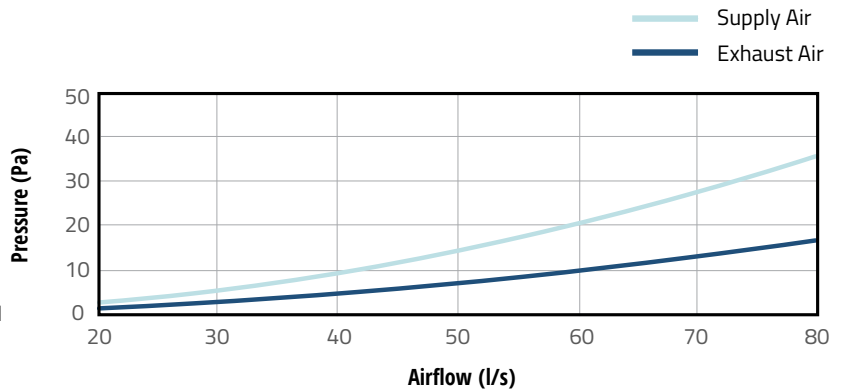

TA390 - Titon FireSafe® Air Brick 330x60x400/
TA391 - Titon FireSafe® Air Brick 330x60x400 Bezelled
TA392 - Titon FireSafe® Air Brick 330x60x500/
TA393 - Titon FireSafe® Air Brick 330x60x500 Bezelled

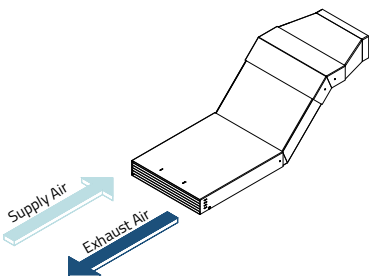
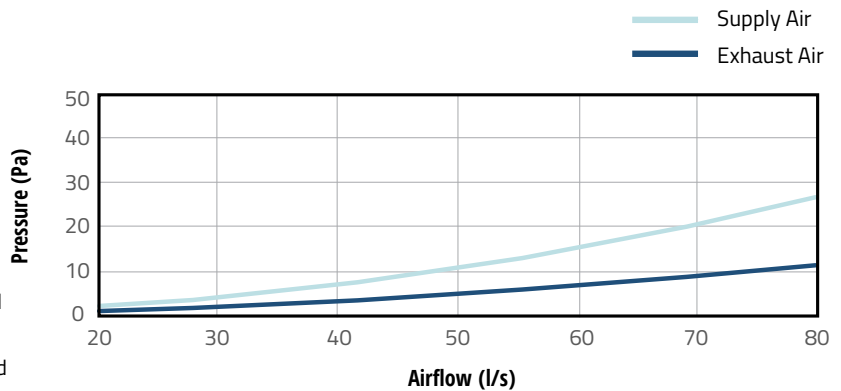

TA390 - Titon FireSafe® Air Brick 330x60x400/
TA391 - Titon FireSafe® Air Brick 330x60x400 Bezelled
TA392 - Titon FireSafe® Air Brick 330x60x500/
TA393 - Titon FireSafe® Air Brick 330x60x500 Bezelled

with **TA382** - 45° Bend 330x60 and **TA383** - Transition 330x60 to 220x90
 *Resistance curve - air brick and accessory combined.

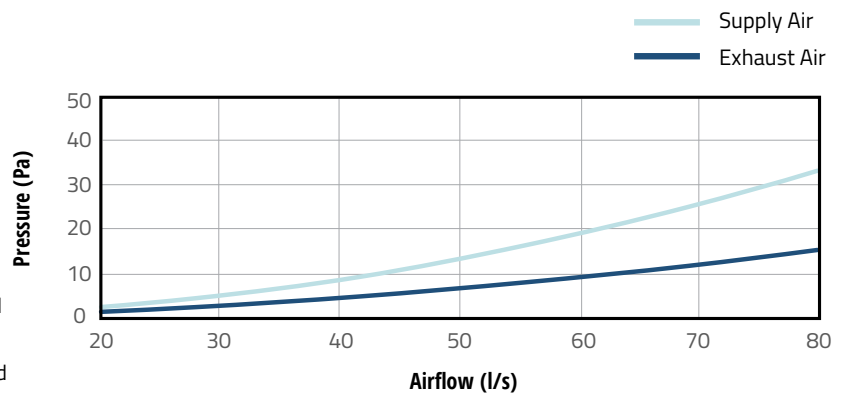

Drawings & Dimensions

TA360, TA370, TA380, TA390 & TA392 - Titon FireSafe® Air Brick

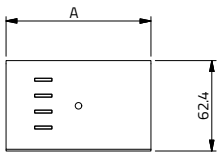
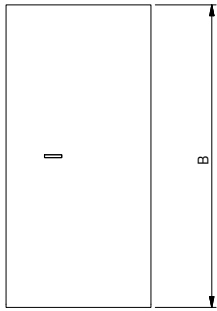

Product Size	Part Number	A	B	Weight (Kg)
204x60x100	TA360	100	208.8	1.2
204x60x400	TA370	400	208.8	3.0
330x60x100	TA380	100	330	1.8
330x60x400	TA390	400	330	4.3
330x60x500	TA392	500	330	5.2

TA361, TA371, TA381, TA391 & TA393 - Titon FireSafe® Air Brick Bezel

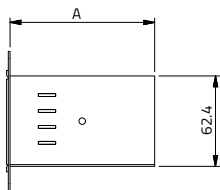
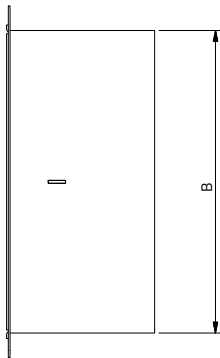

Product Size	Part Number	A	B	Weight (kg)
204x60x100	TA361	100	208.8	1.3
204x60x400	TA371	400	208.8	3.1
330x60x100	TA381	100	330	2
330x60x400	TA391	400	330	4.5
330x60x500	TA393	500	330	5.4

Bezel

204x60

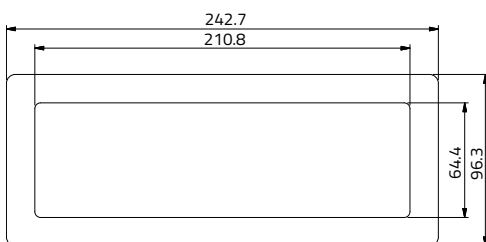

330x60 Version

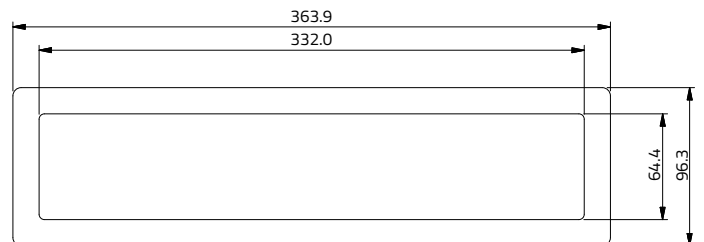

Drawings & Dimensions

TA383 - Transition 330x60 to 220x90

Weight - 1.5kg

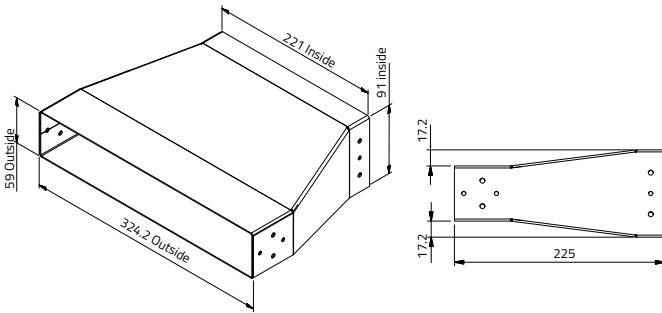

TA385 - Transition 330x60 to 220x90 Flat Top Profile

Weight - 1.5kg

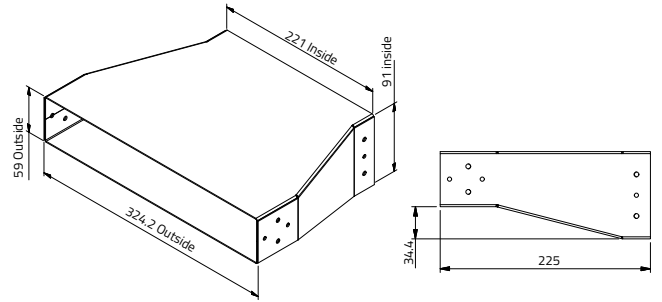

TA362 - 45° Bend 204x60

Weight - 2.7kg

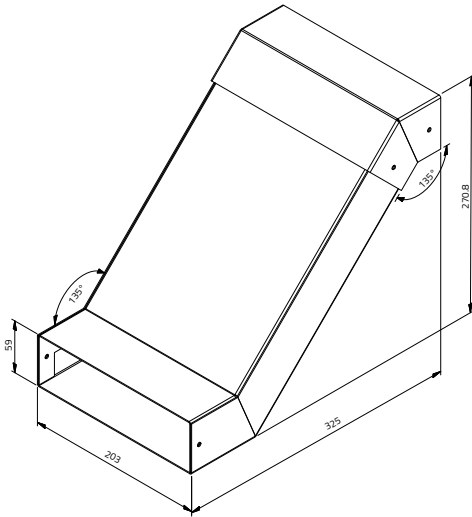

TA382 - 45° Bend 330x60

Weight - 3.7kg

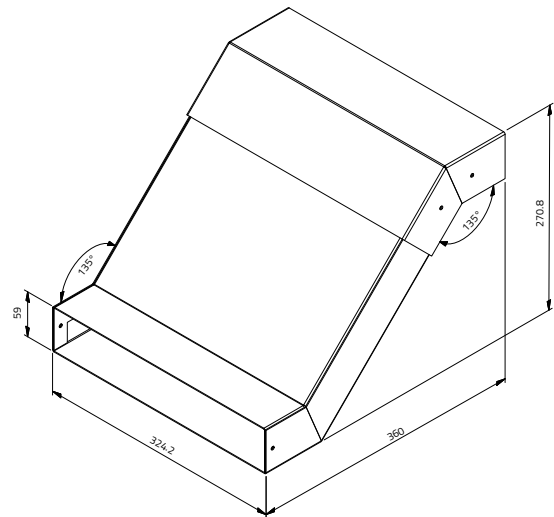

TA363 - Metal Sleeve 204x60x200

Weight - 1kg

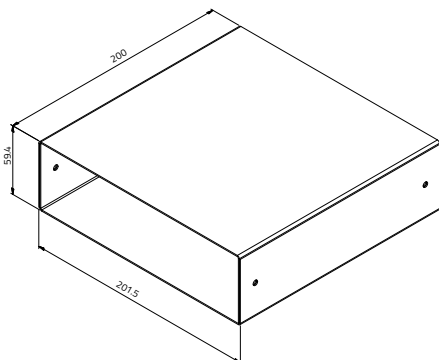

TA384 - Metal Sleeve 220x90x400

Weight - 2.5kg

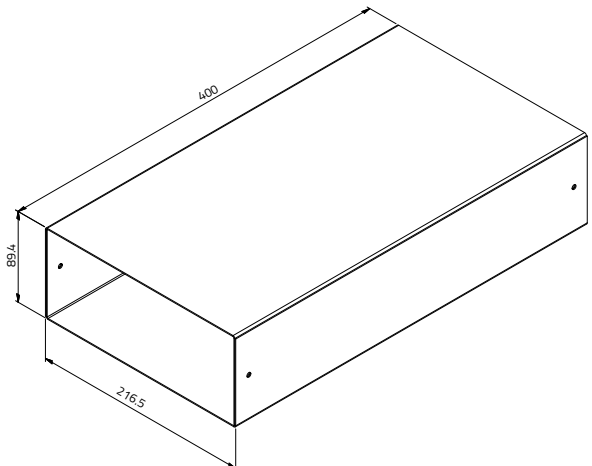

Titon FireSafe® - Double Air Brick

For use with Titon's HRV Q Plus and CME Q Plus Ranges

The new Titon FireSafe® Air Brick Range is a unique high flow terminal designed for powered ventilation systems offering low resistance to airflow, but high resistance to fire as set out in Approved Document B (fire safety) volume 1: Dwellings, 2019 edition. Constructed from sheet steel (A1) and polyester powder coated to classification A2-s1, d0.

The Titon FireSafe® Air Brick is designed to be built into external wall types during construction. The range consists of short and long versions and can easily be connected to 220x90 rectangular ducting.

Description

Titon FireSafe® Double Air Brick



FireSafe



Product Codes

- TA364** - Titon FireSafe® Air Brick 204x128x100/
- TA365** - Titon FireSafe® Air Brick 204x128x100 Bezelled
- TA372** - Titon FireSafe® Air Brick 204x128x400/
- TA373** - Titon FireSafe® Air Brick 204x128x400 Bezelled
- TA374** - Titon FireSafe® Air Brick 204x128x500/
- TA375** - Titon FireSafe® Air Brick 204x128x500 Bezelled

Accessories

- TA366** - Transition 204x128 to 220x90
- TA384** - Metal Sleeve 220x90x400

Features & Benefits

- Polyester Powder Coating meeting EN13501-1 classification A2-s1,d0
- Material 1mm Electrogalvanized Sheet Steel, fire class A1 'no contribution to fire'
- Designed for 220x90 ducting
- Bezelled version for use with exterior cladding instead of brickwork
- Complies with the latest standard as set out in Approved Document B (fire safety) volume 1: Dwellings, 2019 edition
- High flow terminal designed for powered ventilation systems offering low resistance to airflow and high resistance to fire
- Extensive versatile range for different installation options
- Registered Design
- Also available in Single brick (204x60 and 330x60) options
- Special paint finishes available depending on quantity
- Performance tested to BS EN13141-2:2010
- Corrosion resistance - salt spray tested to BS EN ISO 9227:2012
- Optional lengths available at request
- Compatible with thermal and rigid ducting

Specification

Materials:

Steel Electrolytically Zinc Coated (BS EN 10152 DC01 ZE25/25)

Paint:

Powder Coated (A2-s1, d0 classification to EN 13501-1)

Registered Design

- TA364** - Registered Design No 6080907
- TA372** - Registered Design No 6080908
- TA374** - Registered Design No 6080908

Finishes: Terracotta, Sand, Grey, White or Brown

Colour Reference (add to end of part number)

- /023 - Brown (Semigloss RAL 8017)
- /086 - Terracotta (Matt RAL 8004)
- /151 - White (Matt RAL 9010)
- /397 - Grey (Matt RAL 7012)
- /626 - Sand (Matt RAL 1001)

Installation:

Install in accordance with Residential Ventilation Association Good Practice recommendations – details on request.

Maintenance: Wipe with a damp cloth and remove any blockages on a regular basis.

Free Area:

TA364, TA365, TA372, TA373, TA374 & TA375
Titon FireSafe® Air Brick AAO = 20,111 mm²

High Flow Terminal Resistance - 204x128x100/400/500

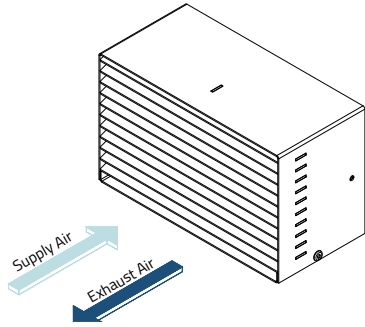

- TA364** – Titon FireSafe® Air Brick 204x128x100/
 - TA365** – Titon FireSafe® Air Brick 204x128x100 Bezelled With
 - TA366** – Transition 204x128 to 220x90
- *Resistance curve - air brick and accessory combined.

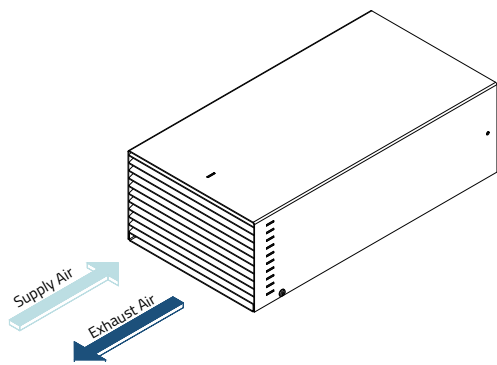
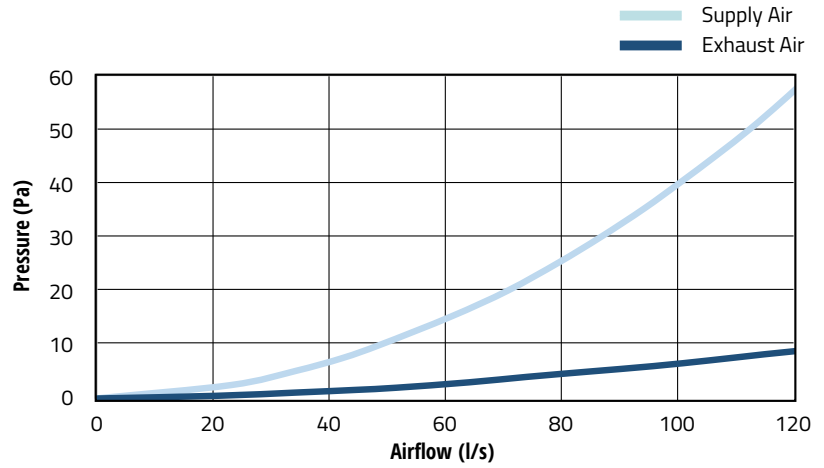

- TA372** – Titon FireSafe® Air Brick 204x128x400/
 - TA373** – Titon FireSafe® Air Brick 204x128x400 Bezelled
 - TA374** – Titon FireSafe® Air Brick 204x128x500/
 - TA375** – Titon FireSafe® Air Brick 204x128x500 Bezelled
- With
- TA366** – Transition 204x128 to 220x90~
- *Resistance curve - air brick and accessory combined.

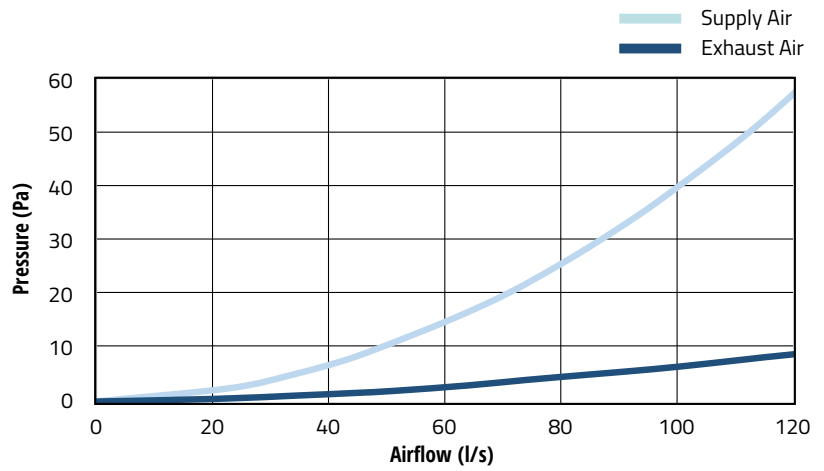

Drawings & Dimensions

TA366 - Transition 204x128 to 220x90

Weight - 1.4kg

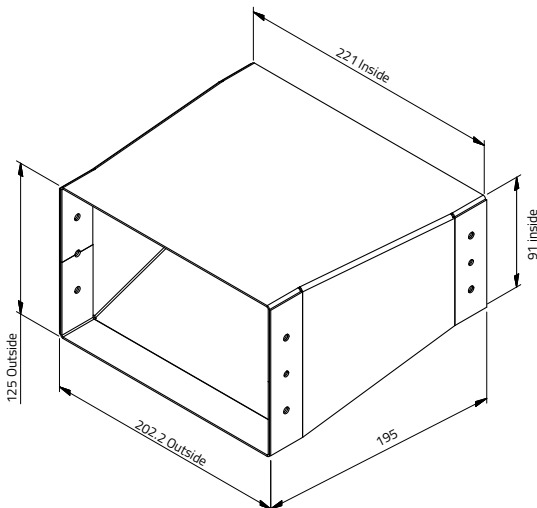

TA384 - Metal Sleeve 220x90x400

Weight - 2.5kg

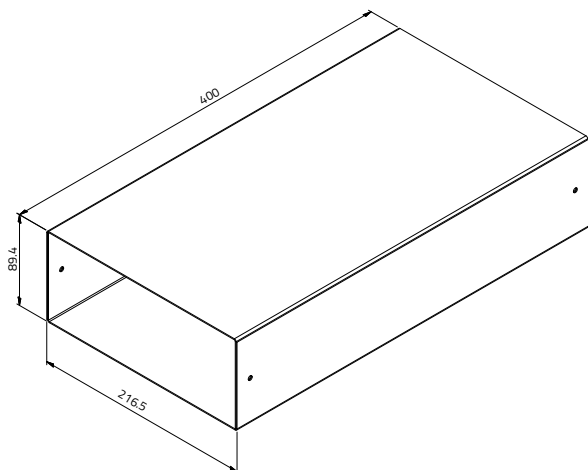

Drawings & Dimensions

TA364, TA372, TA374 - Titon FireSafe® Double Air Brick

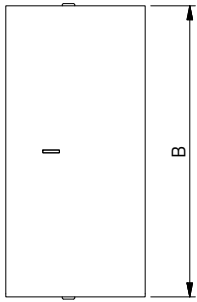

Product Size	Part Number	A	B	C	Weight (kg)
204x128x100	TA364	100	209	129	2.2
204x128x400	TA372	400	209	129	4.8
204x128x500	TA374	500	209	129	5.7

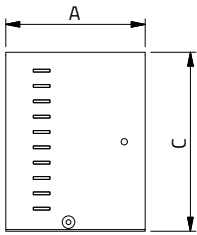

TA365, TA373, TA375 - Titon FireSafe® Double Air Brick Bezel

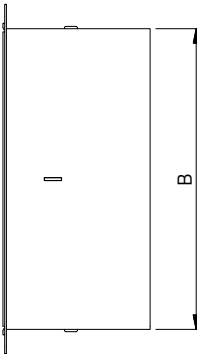

Product Size	Part Number	A	B	C	Weight (kg)
204x128x100	TA365	100	209	129	2.4
204x128x400	TA373	400	209	129	5
204x128x500	TA375	500	209	129	5.8

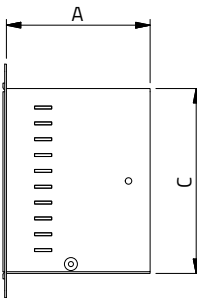

Bezel - 204x128

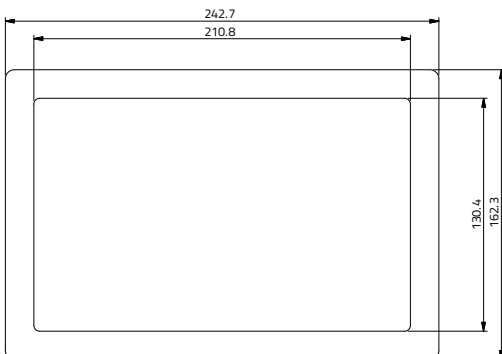

Titon FireSafe® - 100mm Push Through Wall Kit

For use with Titon's dMEV and CME Q Plus Ranges

The **new** Titon FireSafe® 100mm Push Through Wall Kit is a circular high flow terminal designed for powered ventilation systems offering low resistance to airflow, but high resistance to fire as set out in Approved Document B (fire safety) volume 1: Dwellings, 2019 edition.

Ideal for new build, refurbishment and social housing residential applications, it is constructed from sheet steel (A1) and polyester powder coated to classification A2-s1, d0.

Titon FireSafe® 100mm Push Through Wall Kit is designed to be installed from the inside of the dwelling and will create a seal to the external wall. The range consists of a Ø100 round version at 630mm long.

FireSafe

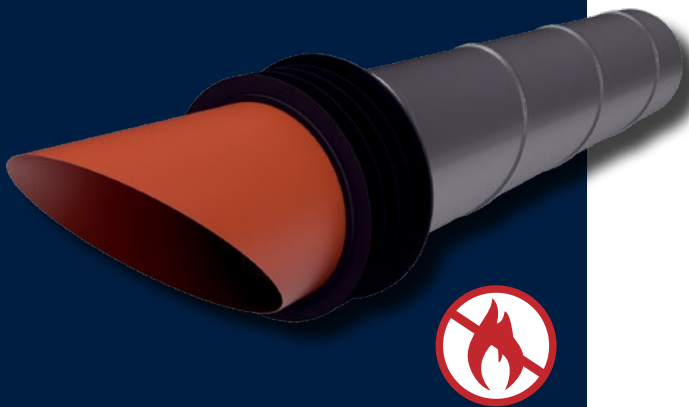

Features & Benefits

- Material 0.6 – 1.0mm hot dipped galvanised sheet, fire class A1 'no contribution to fire'
- Polyester powder coating meeting EN13501-1 classification A2-s1,d0
- Ideal for retrofit where mould and condensation are a major problem
- Designed for installation with Titon Ultimate® dMEV
- Can be cut to desired wall thickness
- Performance tested to BS EN13141-2:2010
- Corrosion resistance - salt spray tested to BS EN ISO 9227:2012
- Special paint finishes available depending on quantity
- Compatible with thermal and rigid ducting
- Compatible with Titon's range of MEV fans
- Rubber round gasket to seal with external wall
- Complies with the latest standard as set out in Approved Document B (fire safety) volume 1: Dwellings, 2019 edition
- High flow terminal designed for powered ventilation systems offering low resistance to airflow and high resistance to fire



Description

Titon FireSafe® 100mm Push Through Wall Kit

Product Codes

TA425 - Titon FireSafe® 100mm Push Through Wall Kit, Ø100 and 630mm long

Specification

Materials:

Hot Dipped Galvanised Steel

Paint:

Powder Coated (A2-s1, d0 classification to EN 13501-1)

Rubber Gasket: Thermoplastic Elastomer (TPE)

Finishes: Terracotta and White*

Colour Reference (add to end of part number)

/086 - Terracotta (Matt RAL 8004)

/151 - White (Matt RAL 9010)

*Terminal only (excluding ducting) and other colours available at request.

Installation:

Install in accordance with Residential Ventilation Association Good Practice recommendations – details on request.

Maintenance: Wipe with a damp cloth and remove any blockages on a regular basis.

Free Area:

AAO = 6174 mm²

Drawings & Dimensions

TA425 - Titon FireSafe® 100mm Push Through Wall Kit

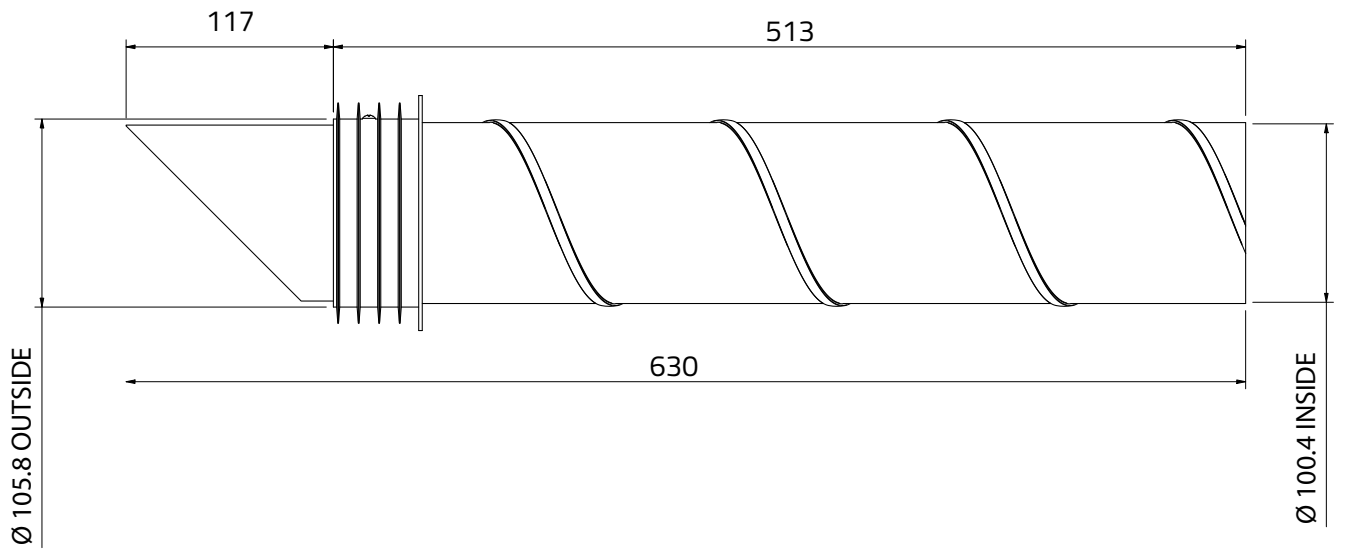

Dimensions in mm



High Flow Terminal Resistance

TA425 - Titon FireSafe® 100mm Push Through Wall Kit

— Exhaust Air

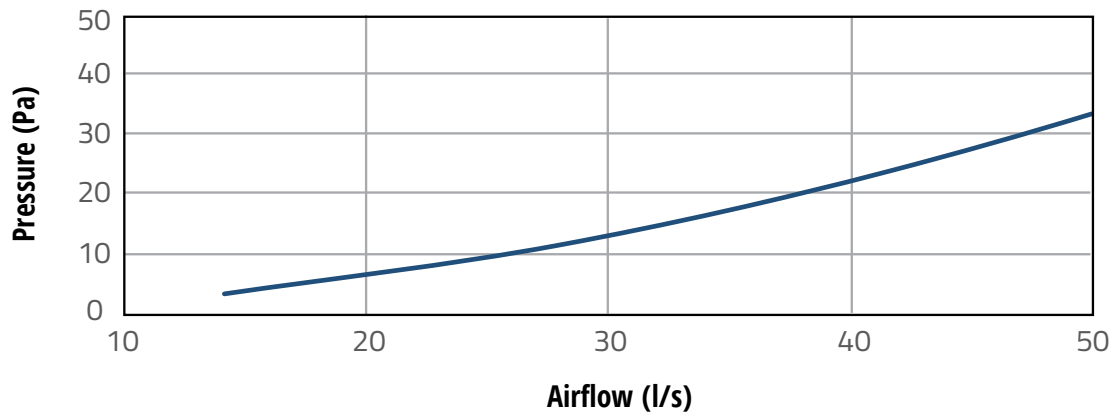

Fire Sleeve - Ducting

For use with Titon's HRV Q Plus and CME Q Plus Ranges

Fire Sleeves prevent the spread of fire where plastic pipes or plastic ducts penetrate fire compartment walls.

Regulations

Building Regulations impose limitations on all pipes passing through fire compartment walls and floors. QRS Intumescent Fire Sleeves allow plastic ducts to meet the requirements of the Building Regulations. QRS Intumescent Fire Sleeves have been tested according to BSEN 1366-3: 2009 where various plastic duct sizes have met insulation and integrity criteria for this standard for up to 2 hours.

Fire Sleeve



Features & Benefits

- Tested to BSEN 1366-3: 2009
- Tested with Uncapped/Uncapped (U/U) duct configurations as required for ventilation ducts
- Up to 2 hour fire rating
- Suitable for masonry walls or plasterboard partitions
- Suitable for insulated and non-insulated partitions
- Can be retrofitted
- No mechanical fixings required
- Robust galvanised steel shell
- Performance unaffected by weathering (Type X Durability)

Composition

The QRS Intumescent Fire Sleeves consist of a flexible galvanised steel shell containing graphite based intumescent material.

They are manufactured to suit flat ducts of 110x54mm, 204x60mm, and 220x90mm. And round ducts with 100mm and 125mm overall diameter.

Durability

Tested to Type X durability which means the QRS Fire Sleeves can be installed in conditions exposed to weathering. QRS CE/UKCA Marked Fire Sleeves are expected to last the lifetime of the building.

Applications/Installation

The QRS Intumescent Fire Sleeve should be placed around the ventilation duct, positioned centrally within the partition and should be flush or protrude from each face of the wall. The plasterboard should be cut to a tight fit around the QRS Intumescent Fire Sleeve, and any gaps should be sealed with the Quelstop Intumescent Acrylic Sealant, part number QSS310.

For all sleeve types, please refer to manufacturers installation guidance prior to system design or installation.

Performance

Product Code	Duct Size (mm)	Space needed around duct to fit QRS Slim Sleeve (mm)	Recommended aperture (mm)	QRS length (mm)	Fire Rating
QRS110/54	110 x 54	9	130 x 73	140	120 minutes
QRS205/60	204 x 60	9	225 x 80	180	120 minutes
QRS220/90	220 x 90	18	256 x 126	140	120 minutes
QRS110*	100	10	130	180	120 minutes
QRS130*	125	20	170	180	90 minutes
QRS 75	75 Semi rigid	8	90	140	120 minutes
QRS 90*	90 Semi Rigid	13	116	140	120 minutes

* QRS110, QRS130 and QRS 90 are not currently CE/UKCA Marked

QRS Fire Sleeve installed in plasterboard partition



Fire Sleeve (Slim) - Ducting

For use with Titon's HRV Q Plus and CME Q Plus Ranges

Slim Fire Sleeves prevent the spread of fire where plastic pipes penetrate fire compartment walls.

They are specifically designed to be slim for applications where there is limited space around the duct.

Regulations

Building Regulations impose limitations on all pipes passing through fire compartment walls and floors. QRS Vent Duct Slim Sleeves allow plastic ducts to meet the requirements of the Building Regulations. QRS Vent Duct Slim Sleeves have been tested according to BSEN 1366-3: 2009 where various plastic duct sizes have met insulation and integrity criteria for this standard for up to 2 hours.

Fire Sleeve



Features & Benefits

- Tested to BSEN 1366-3: 2009
- Tested with Uncapped/Uncapped (U/U) duct configurations as required for ventilation ducts
- Up to 2 hour fire rating
- Very slim-line (saves ceiling space)
- Suitable for masonry walls or plasterboard partitions
- Suitable for insulated and non-insulated partitions
- Can be retrofitted
- No mechanical fixings required
- Robust galvanised steel shell
- Performance unaffected by weathering (Type X Durability)

Compositions

The QRS Vent Duct Slim Sleeves consist of a flexible galvanised steel shell containing graphite based intumescent material.

They are manufactured to suit flat ducts of 110x54mm, 204x60mm and 220x90mm.

Durability

Tested to Type X durability which means the QRS Vent Duct Slim Sleeves can be installed in conditions exposed to weathering. QRS Vent Duct Slim Sleeves are expected to last the lifetime of the building.

QRS CE/UKCA Marked Fire Sleeves are expected to last the lifetime of the building.

Applications/Installation

The QRS Vent Duct Slim Sleeves should be placed around the ventilation duct, positioned centrally within the partition and should be flush or protrude from each face of the wall. The plasterboard should be cut to a tight fit around the QRS Vent Duct Slim Sleeves, and any gaps should be sealed with the Quelstop Intumescent Acrylic Sealant, part number QSS310.

For all sleeve types, please refer to manufacturers installation guidance prior to system design or installation.

Performance

Product Code	Duct Size (mm)	Space needed around duct to fit QRS Slim Sleeve (mm)	Recommended aperture (mm)	QRS length (mm)	Fire Rating
QRS110/54SS	110 x 54	5	122 x 66	140	120 minutes
QRS204/60SS	204 x 60	5	216 x 72	140	90 minutes
QRS220/90SS	220 x 90	9	241 x 112	140	60 minutes

QRS Slim Fire Sleeve installed in plasterboard partition



CFC Ceiling Fan Cuff

For use with Titon Ultimate® dMEV

CFC Ceiling Fan Cuffs prevent the spread of fire through ceilings where plastic ceiling fans penetrate the fire line plasterboard.

Composition

The CFC Ceiling Fan Cuffs consist of a continuous pressed stainless steel flexible shell containing a high performance graphite based intumescent material, which reacts under the influence of heat to exert pressure on the duct as it softens to form a carbonaceous char. This provides an effective insulation plug thus preventing fire passing through to the adjoining compartment. The CFC has built in spring clips which hold it to the plasterboard ceiling.



Features & Benefits

- Tested generally in accordance with BS EN 1364-2: 2018 Fire Resistance Tests for non-loadbearing elements – Part 2: Ceilings and additional guidance from BS EN 1366-3: 2009. (Test Report 510322B/R)
- Up to 60 minutes Integrity and Insulation.
- Can be retrofitted
- Specifically tested with the Titon Ultimate® dMEV

Product Code	Description
CFC100	CFC Ceiling Fan Cuff
QSS310	Quelstop Acrylic Sealant

Applications/Installation

1. Cut the plasterboard aperture to $\varnothing 135\text{mm}$ around the $\varnothing 100\text{mm}$ PVC duct spigot.
2. Centralise the $\varnothing 100\text{mm}$ PVC duct spigot Within the hole.
3. From the underside push the CFC100 up into the aperture around the PVC duct ensure the spring clip clamps fully back onto the plasterboard and that the CFC100 is clamped tight in position.
4. Make sure the gap between the CFC100 and the plasterboard is clean of any debris and remove dust from all edges.
5. Seal the small gap between the CFC100 and the plasterboard with QuelStop Acrylic Sealant.
6. Install the ceiling fan to the plasterboard with correct screw fixings in accordance with Titon installation instructions.

The CFC has been tested in the scenario shown with the Titon Ultimate® dMEV. The customer/installer should satisfy themselves, or consult a fire engineer that the product, test data available, standards to which the product is tested, fan units and ducting, floor/ceiling construction is applicable and satisfactory for their specific scenario as Titon are not able to comment on each and every scenario.

Self-Seal Connectors

For use with Titon's HRV Q Plus and CME Q Plus Ranges

Titon's self-seal connectors offer a simple, mess free, solution to reduce air leakage when it comes to ducting a ventilation system.

All new installations have to be performance tested on completion and achieve predetermined airflows at extract and supply points to meet the required standards. This means that air leakage at the joints in ventilation ducting systems has become a major concern, because leakage will adversely affect the airflow performance and balance of the system. Plus, if the installed performance does not achieve the minimum design performance, then expensive remedial work will be required.

The traditional method of reducing air leakage at the joints is to apply silicon sealant and duct tape in and around the joints, which is labour intensive, messy to apply, not always effective and difficult to dismantle. Self-seal ducting solves these problems by providing tape free, sealant free, very airtight connections. This cuts down on installation time, mess and waste.

Self-Seal



Features & Benefits

- Fast fit, reduced labour demand
- Uniquely shaped gasket, no air leakage
- BRE tested, test report No. 285430
- Simple push-fit couplings
- Silicon and duct tape free installation
- Withstands both negative and positive pressure

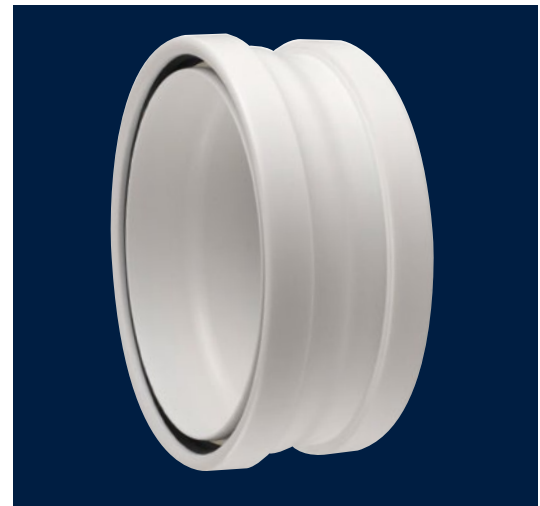

125Ø Round Self-Seal Connector

	Product Code	Product Description
	8960250	125Ø Duct to Fitting Self-Seal Connector
	8960251	125Ø Duct to Duct Self-Seal Connector
	8960252	204 x 60mm Ducting to Duct Self-Seal Connector
	8960253	204 x 60mm Ducting to Fitting Self-Seal Connector
	8960270	220 x 90mm Ducting to Duct Self-Seal Connector
	8960271	220 x 90mm Ducting to Fitting Self-Seal Connector

For use with Titon's standard PVC ducting range.



204 x 60 Rectangular Self-Seal Connector

Roof Terminals

For use with whole-house (MVHR or CME) ventilation systems

A range of high performance roof terminals to suit the majority of popular roofing materials, specifically designed for mechanical ventilation applications. The inappropriate use of roof terminals not designed for mechanical ventilation systems can severely compromise performance.



Description:

Pitch roof (slate and tile) supply or exhaust terminal with flashing and integral condensate drain.

Product code: UB34

Specification:

Diameter connection: 125mm
 Type of tile: Universal
 Ventilation capacity: 12,250mm²
 Resistance @ 28l/s: 0.2 Pa
 Hooded: Stack
 Material: PP
 Finish: Black
 Roof Pitch - 25-35°

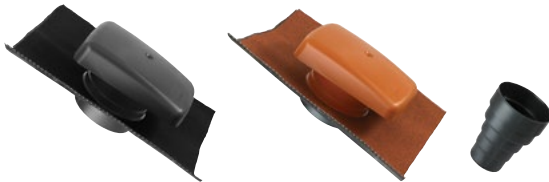

Description:

Pitch roof (slate and tile) supply or exhaust vent with flashing included reducer.

Product code: UB41

Specification:

Diameter connection: Stepped adaptor
 100/110/125/150/160mm
 Type of tile: Universal
 Hooded: Hooded
 Material: PVC/Ubiflex
 Finish: Black or Terracotta
 Roof Pitch - Minimum 22.5°

Diameter (mm)	Free vent Area (mm ²)	Pressure/Airflow Resistance (Pascals)	
		28l/s	62.5l/s
100	7850	3	7.5
110	8850	4.5	16
125	12250	5.3	24
150	17775	6.5	31
160	18750	6.5	31



Description:

Flat roof (felt or asphalt) supply or exhaust terminal with flashing and integral condensate drain.

Product code: OFT4/131

Specification:

Diameter: 125mm
 Height over roof: 400mm
 Height under roof: 350mm
 Diameter of flange: 450mm
 Ventilation capacity: 12,000mm²
 Resistance @ 28l/s: 0.2 Pa
 Material: PP/ALU
 Finish: Black

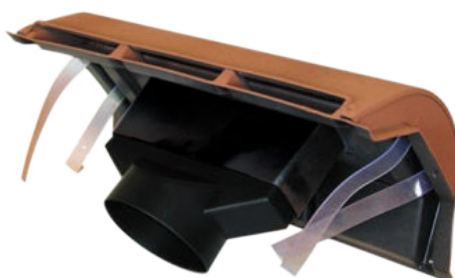

Description:

Ridgeline Vent designed to replace a normal ridge tile and are available to match all popular ridge tiles and can also be made to match obsolete tiles. (For extract only)

Product code: 9020001

Specification:

Diameter: 125mm
 Type of tile: Concrete and clay ridge tiles
 Ventilation capacity: 12,500mm²
 Resistance: 125mm @ 30l/s: 4.0 Pa
 Colour: BN28 – Sandtoft Dark Heather,
 GY11 – Marley Blue/Black,
 RD43CW – Rustic Red

Further Information

If you require more details on Titon's products and services please go to www.titon.com. The Titon website is full of comprehensive information on the complete Titon range. Any recent product specification changes will appear on the site and a subscription service is available to automatically inform you of any updates.

- For details on Titon Part F Ventilation CPD Seminars go to www.titon.com/cpd
- To subscribe to email updates go to www.titon.com/subscribe
- For further information on SAP Appendix Q, how buildings are assessed for energy performance and a list of applicable products, go to www.ncm-pcdb.org.uk
- For Government information on Building Regulations in England & Wales go to www.gov.uk and search for 'Building Regulations'.
- For more information on new home building and NHBC Guides visit the NHBC foundation website www.nhbcfoundation.co.uk
- To download Approved Document F go to www.planningportal.gov.uk/buildingregulations/approveddocuments/partf/approved
- To download other relevant Approved Documents for the Building Regulations (England & Wales) go to www.planningportal.gov.uk/buildingregulations/approveddocuments
- For Scottish Technical Standards go to www.sbsa.gov.uk and search for 'Technical Standards'.
- The trade association for ventilation in housing is the Residential Ventilation Association (RVA), part of the Heating Ventilating & Air Conditioning Manufacturers Association, go to www.feta.co.uk/rva
- For information on BEAMA, the trade associations representing the energy and power industry (Titon is a member of the mechanical ventilation association, TEHVA) go to www.beama.org.uk
- For details on energy efficiency go to the Energy Savings Trust (EST) www.energysavingtrust.org.uk
- To purchase online, please go to www.titondirect.com for a range of products and accessories.

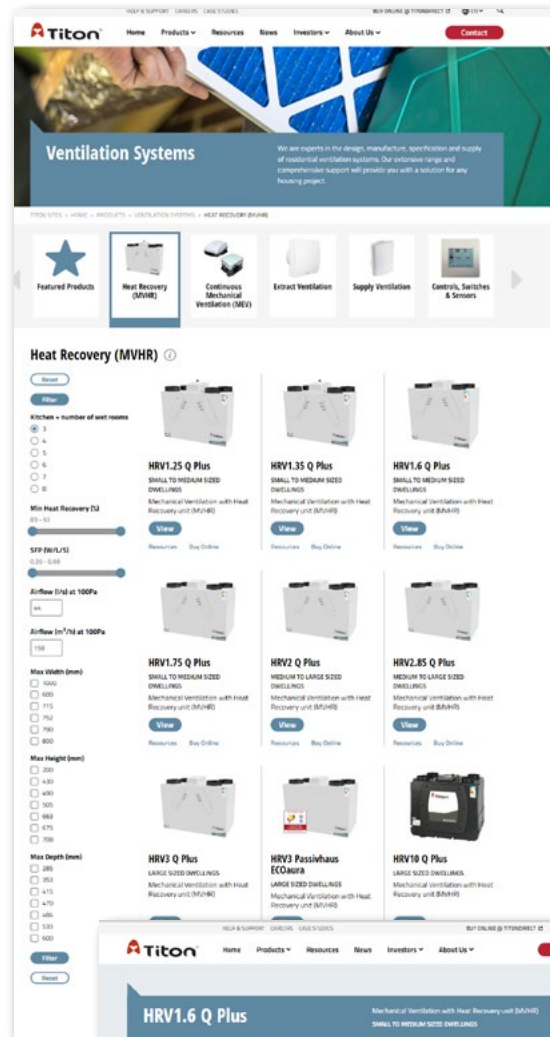

Titon FireSafe® 100mm Push Through Wall Kit

Titon has extended its market leading Titon FireSafe® range by adding the new Titon FireSafe® 100mm Push Through Wall Kit, a superior circular fire safe terminal that assists in removing the dangers offered by plastic grilles and ducting in mechanical ventilation systems.

The Titon FireSafe® 100mm Push Through Wall Kit offers low resistance to airflow, but high resistance to fire as set out in Approved Document B (fire safety) volume 1: Dwellings, 2019 edition. Ideal for residential new build, refurbishment and social housing applications where mould and condensation are a major problem.

Key Features

- › Easy to install and can be cut to desired length on site
- › Performance tested to BS EN13141-2:2010
- › Designed for installation with Titon Ultimate® dMEV
- › Material 0.6mm electrogalvanized sheet steel, fire class A1 'no contribution to fire'
- › Terminal polyester powder coating meeting EN13501-1 classification A2-s1,d0
- › Corrosion resistance - salt spray tested to BS EN ISO 9227:2012

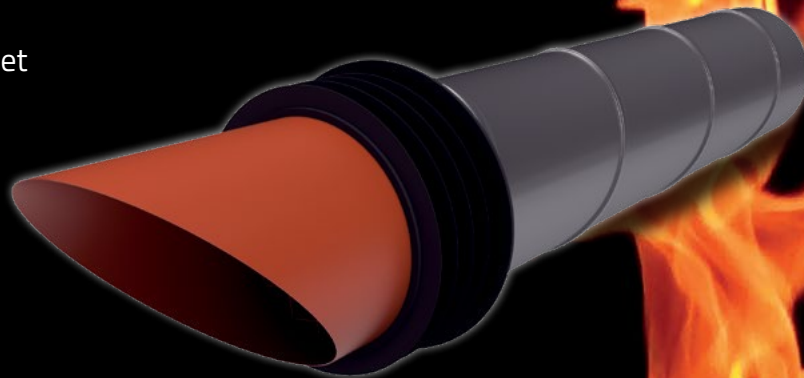

A manufacturer you can BUILD a relationship with....

Visit our dedicated website at:
titon.com/firesafe

t: 01206 713800 e: marketing@titon.co.uk



 **Titon®**



894 The Crescent, Colchester Business Park, Colchester, CO4 9YQ

Tel: +44 (0) 1206 713800

Email: ventsales@titon.co.uk Web: www.titon.com

BM375 Iss.10 (May 24)

Titon operates a policy of continuous improvement and reserves the right to supply products that may differ from those illustrated and described in this publication.