

Titon balanced ventilation ensures an adequate supply of fresh and pure air at home or at work throughout the year. With the Titon WHR350, now an extra compact appliance is available for dwellings and with a need for lower ventilation rates. The efficiency is the same as that of appliances with a higher capacity - up to 89%* of the heat from the inside air is transferred to the fresh, cold air from outside. The combination of high efficiency and limited capacity makes the WHR350 the optimum choice for low-energy ventilation of small spaces.

A HIGHLY COMPACT VENTILATOR

Titon WHR350 is a very compact unit with a maximum capacity of 400 m³/h at 150 Pa. The appliance is available in a right-handed and a left-handed version. The Titon WHR350 has four air connections at the top. All air connections on the unit have a diameter of 150 mm. A low-resistance duct system can be installed directly from the appliance.

FIELD OF OPERATION

The Titon WHR350 heat recovery ventilator needs no more space than a kitchen cupboard. Its modest dimensions and capacity make it suitable for most housing applications, but the Titon WHR350 is also an excellent choice for hotel rooms and for residential buildings subdivided into various types and sizes.

HIGH EFFICIENCY

The synthetic heat exchanger within the Titon WHR350 transfers up to 89% of heat, according to independent BRE testing for SAP Appendix Q. That makes it unnecessary to additionally heat the ventilation air, resulting in considerable savings on heating costs.

FRESH AND PURE AIR

The Titon WHR350 comes with two standard filters that can be easily removed. These filters remove 95% of dust from the air.

CONSTANT FLOW FANS

At every ventilation setting the constant flow fans keep the air quality constant under all conditions. This results in a permanently high efficiency and initial adjustment remains limited to a minimum. Filter fouling does not influence the preset air quality.

FROST PROTECTION

The frost protection system provides optimum protection from freezing. This preserves the unit's high-efficiency.

LOW VOLTAGE CONTROL

The appliance comes as standard with a low voltage control connection. The control data cable is easily plugged in with a data communication connector.



EASE OF INSTALLATION

A display on the appliance for setting and read out functions increases the ease of installation. A cable kit and a computer program are available for service purposes.

THE COMPLETE PACKAGE

Titon can supply not only the ventilator unit, but also the ducting and diffusers to give you the fully specified system, with all the correctly tested components.

* According to independent BRE testing for SAP Appendix Q.

TECHNICAL SPECIFICATIONS

Ventilation capacity at 150 Pa	Maximum 400 m ³ /h
Dimension duct connection	Ø 150 mm
H x W x D	602 x 675 x 430 mm
Weight	32 kg

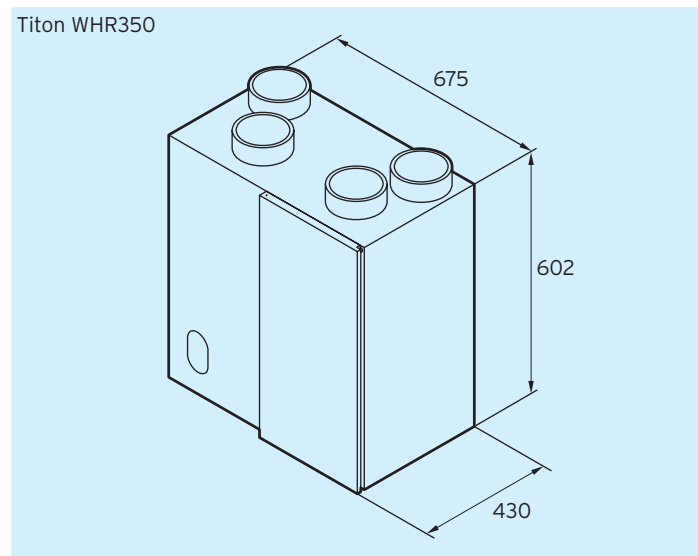

MARKETING DIVISION

International House, Peartree Road, Stanway, Colchester, Essex CO3 0JL
 Tel: +44 (0) 1206 713800 Fax: +44 (0) 1206 543126
 Email: enquiries@titon.co.uk Web: www.titon.com