

HRV1.6 Q Plus - Enthalpy

Ultra energy efficient Heat Recovery Ventilation unit

For use in medium to large sized dwellings

The high capacity HRV1.6 Q Plus continuously running whole-house ventilation unit with heat recovery maintains an ultra compact size despite its improved airflow performance.

Combining extremely low power consumption and a highly efficient heat exchanger, this unit remains versatile enough in size to be equally as functional in large apartments as it is in medium to large sized dwellings.

The counter flow enthalpy heat exchanger has a selective polymer membrane film to achieve low air leakage levels while providing moisture recovery from the exhaust air. These models are ideal for living areas with low humidity, avoiding frost build up at low temperatures, they also have an antimicrobial membrane and long life cycle.

The HRV1.6 Q Plus comes in Eco versions only with a 100% airflow diverting Summer Bypass. They also include intelligent humidity options and can be fitted with the auralite® status indicator, aura-t™, auramode® and aurastat® controllers (BE models only).

MVHR

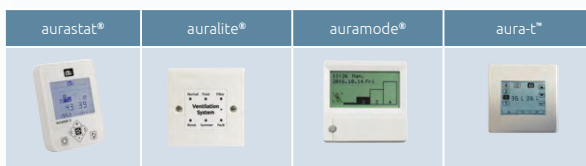

Features & Benefits

- Versatile compact unit
- Highly efficient enthalpy counter flow heat exchanger
- Airflow up to 88l/s (317 m³/h) at 100 Pa
- Accepts 100mm or 125mm diameter ducting, no adaptors required
- Intelligent frost protection
- ISO Coarse 55% (G3) filters as standard, ISO Coarse 60% (G4) as an option
- Fully adjustable boost overrun timer 0-60 minutes; can be used with non-latching (momentary) switches to prevent unit from being accidentally left in boost mode
- Setback facility to reduce ventilation where local regulations allow
- Intelligent Summer Bypass and humidity controls
- Volt free switching control
- Intelligent controller, quick and easy to commission
- Lightweight for easy handling
- Quick fix mounting bracket
- IP32 rating
- On board aura-t™ option
- Patented
- Independent fan adjustment
- SUMMERboost® facility
- Effective in reducing pollutants in the home and improving Indoor Air Quality (IAQ), therefore reducing the risk of Toxic Home Syndrome
- Available in left and right handed configurations
- Compatible with Eco-aura range; aurastat®, auramode® and aura-t™ controllers and auralite® (TP519) status indicator.
- Duct Pre-heater control (requires independent power supply)
- BMS compatible via RS485 (subject to limitations, additional software requirements and specification with any order)

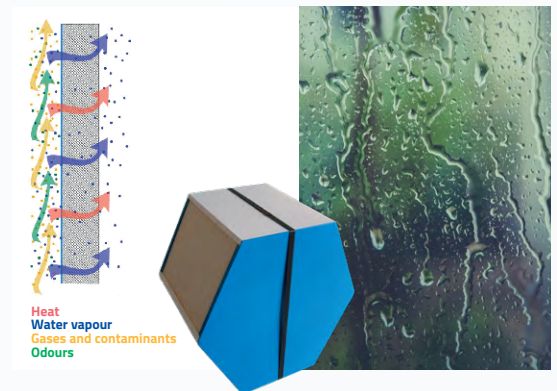

Product Codes

HRV1.6 Q Plus BE Eco Enthalpy Eco-aura controls ready - (Filter Door)

TP429BE/LH (left hand config) or

TP429BE/RH (right hand config) - Energy Rating A+

Filters:

XP2010671/099 - ISO Coarse 55% (G3) filters fitted as standard (UK only).

XP2010897/099 - ISO Coarse 60% (G4) filters fitted on request (Europe fitted as standard).

XP2011096/099 - ISO Coarse 55% (G3)/ISO ePM1 50% (F7) filters available on request.

XP2011097/099 - ISO Coarse 60% (G4)/ISO ePM1 50% (F7) filters available on request.

Standards

EU RoHS Directive compliant.

Conforms to requirements of EC council directives relating to Electromagnetic Compatibility and Electrical Safety:

2006/95/EC (LVD), 2004/108/EC (EMC)

EN 60335-1:2002/A2:2006, EN 60335-2-80:2003/A1:2004.

CE Marked.

Specification

Dimensions: 600mm wide x 505mm high (excluding ports) x 353mm deep (363mm with mounting bracket)

Weight: 25kg

Finish: White Paint

Materials:

Housing: Zintec sheet steel housing, powder coated white

Internals: Expanded polypropylene (EPP)

Heat exchanger: Selective polymer membrane film

Internal insulation: Closed cell foamed

Nitrile rubber, class 'O' fire rating

Standard filters: Grade ISO Coarse 55% (G3) synthetic filters

Guarantee period: 3 years (UK only)

Electrical: 230V ~ 50/60Hz, 3A fuse

Installation: Install in accordance with regulatory requirements, such as the Ventilation: Approved Document F and the Residential Ventilation Association recommendations.

Maintenance: Service and filter clean/replacement subject to local environment - see product manual.

Acoustics: Full acoustic data available online www.titon.com/acoustics.

Drawing & Dimensions

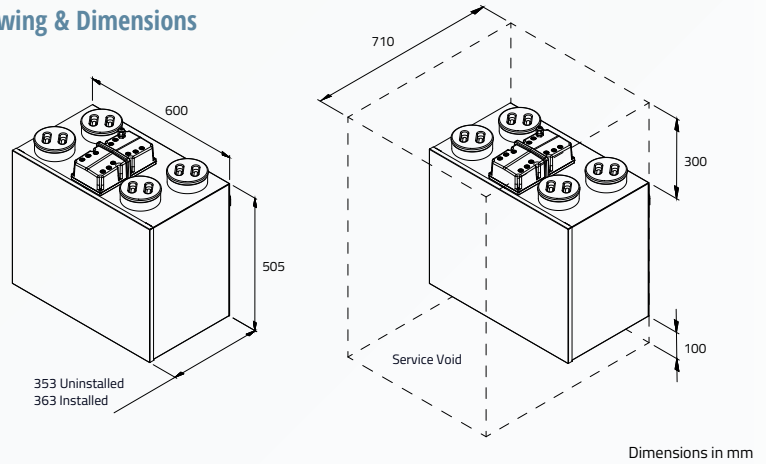

Heat Cell

Technical Data

(Typical conditions at 140 m³/h)

- Heat change rate 80%
- Degree of moisture change 70%
- Leakage at 100 Pa < 1%
- Temperature stability - 25°C up to 65°C

Features & Benefits

- No transfer of gases or pollutants - only heat and water vapour transferred by the membrane
- Long life cycle - permanent transmission parameters
- Minimum leakage
- Optimum flow behaviour, low pressure loss
- Frost- and heat-proof
- High, sensitive and latent transmission rate
- Antimicrobial (Microban® - integrated hygiene protection)
- Can be cleaned using water
- European manufactured heat cell

Nominal Fan Performance

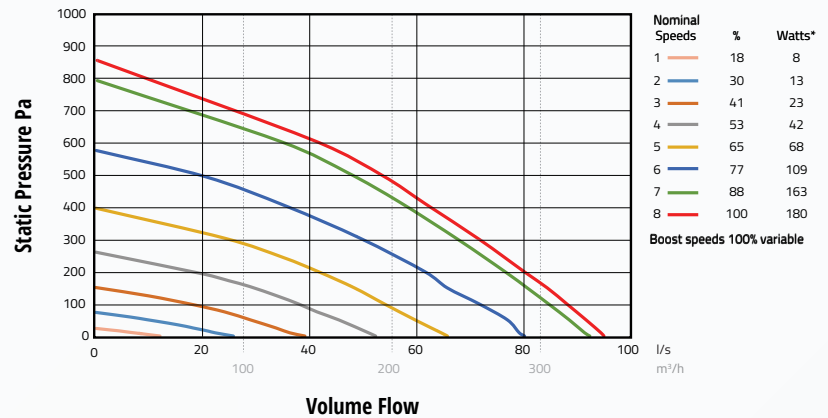

*@FID (0 Pa)

100% variable speed control. Performance curves for Eco version.

Acoustic Data

Product	% of Max flow	Airflow	dB(A) @ 3m Hemispherical			dB(A) @ 3m Spherical
			Induct Inlet	Induct Outlet	Casing Breakout	Casing Breakout
HRV1.6 Q Plus Enthalpy	41%	35l/s @ 17Pa	33	42	18	15
	65%	60l/s @ 54Pa	44	50	30	27
	100%	88l/s @ 100Pa	54	63	43	40

For full frequency acoustic data at various speeds please see www.titon.com. All acoustic data is third party tested at Sound Research Laboratories (SRL) Ltd.