

## EU DECLARATION OF CONFORMITY

---

Product HRV1.65 *Q Plus* Eco HMB  
Part Number TP410HMB-544-T  
Manufacturer Titon Hardware Limited  
Address 894 The Crescent, Colchester Business Park, Colchester, Essex, CO4 9YQ, UK.

This declaration of conformity is issued under the sole responsibility of the manufacturer.

Product Type Mechanical Heat Recovery Ventilation Unit

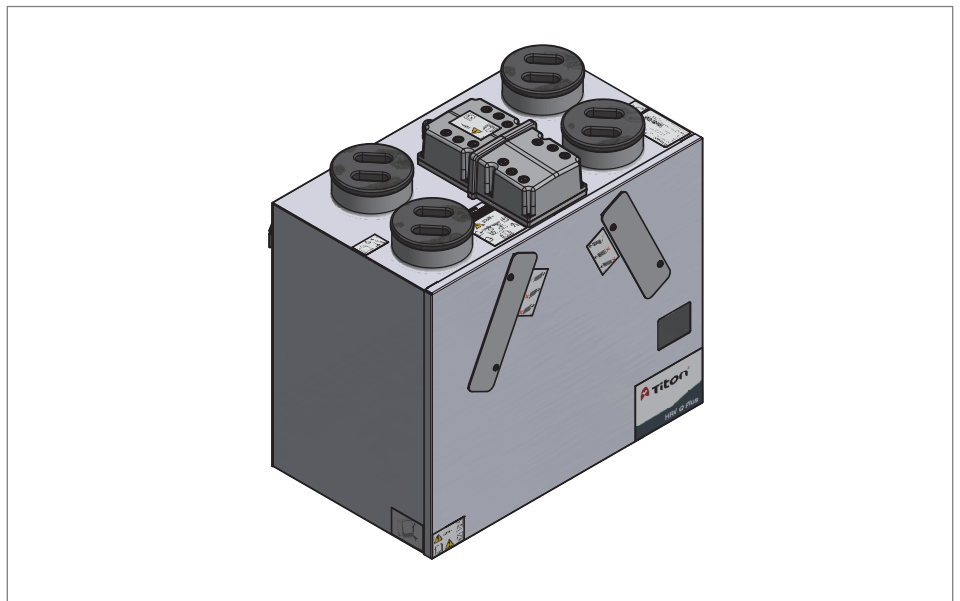

This object of the declaration described above is in conformity with the relevant Union harmonised legislation:

**Harmonised legislation:**

1253/2014 Ecodesign  
1254/2014 Energy Labelling  
2014/35/EU Low Voltage  
2014/30/EU Electromagnetic Compatibility  
2012/19/EU Waste Electrical and Electronic Equipment

**Harmonised Standards:**

BS EN 13141-7  
BS EN 55014-1  
BS EN 55014-2  
BS EN 60335-1  
BS EN 60335-2-80  
BS EN 61000-3-2  
BS EN 61000-3-3

Signed for and on the behalf of:

Titon Hardware Limited  
894 The Crescent, Colchester Business Park, Colchester, Essex, CO4 9YQ, UK.

Date:

11th November 2021



Mat Norris  
Chief Executive

Mat Norris  
Operations Director (Acting)

Paul S Cowell BEng (Hons) CEng MCIBSE  
Technical Director